

**CITY OF FRUITA**

**DESIGN CRITERIA AND CONSTRUCTION**

**SPECIFICATIONS MANUAL**

This Design Criteria and Construction Specifications Manual is adopted by Resolution of the City Council and effective this 7<sup>th</sup> day of July, 2009 by the City of Fruita.



---

**Clint Kinney, City Manager**



---

**Ken Haley, City Engineer**

This Manual supersedes all previous design criteria and construction specifications for the City of Fruita.

**CITY OF FRUITA**

**DESIGN CRITERIA**

**AND**

**CONSTRUCTION SPECIFICATIONS**

**MANUAL**



**2009 Edition**

## **TABLE OF CONTENTS**

<b>CHAPTER 1</b>	<b>Introduction</b>
<b>CHAPTER 2</b>	<b>Water System Standards</b>
<b>CHAPTER 3</b>	<b>Sanitary Sewer Standards</b>
<b>CHAPTER 4</b>	<b>Street System Standards</b>
<b>CHAPTER 5</b>	<b>Concrete Standards</b>
<b>CHAPTER 6</b>	<b>Storm Drainage/Erosion Control Standards</b>
<b>CHAPTER 7</b>	<b>Irrigation System Standards</b>
<b>CHAPTER 8</b>	<b>Inspection and Acceptance</b>

## Chapter 1

### INTRODUCTION

#### POLICIES AND PROCEDURES FOR PUBLIC IMPROVEMENT PROJECTS FOR THE CITY OF FRUITA, COLORADO

##### Sections:

- 1.1: Purpose**
- 1.2: Design Policy**
- 1.3: Construction Policy**
- 1.4: General Details**

##### **1.1: Purpose**

The purpose of these Engineering Specifications is to provide minimum standards to safeguard life and limb, health, property and public welfare by regulating the design of, construction of, choice of materials used for, location of, maintenance and use of all public improvements and common facilities and have been prepared to assist engineers preparing plans for public improvements in the City of Fruita. These include, but are not limited to, sanitary sewer systems, water supply systems, private utility services lines and appurtenances, public and private storm drainage systems, public and private streets, open space, parks and recreation facilities, traffic signals and devices, public and private parking lots and appurtenances thereto. All equipment and material shall be new unless approved by the City of Fruita.

These Engineering Specifications represent minimum requirements and design values. Additional requirements of higher design values, commensurate with conditions, may be required by the City Engineer if, in his judgment, they are in the best interest of the City. Variations may be permitted based solely on sound engineering practice and will be reviewed and approved by the City Engineer's Office on an individual basis. Such variations must be requested in writing along with sufficient documentation supporting the request.

Staff updates and revisions to the policies, procedures and specifications addressed in this document may be administratively published as supplemental guides and specifications prior to a complete revision of this document. These supplemental revisions will have the same degree of compliance and guidance as those guides and specifications found in the original document. The supplements can also be found on the City of Fruita website: [www.fruita.org](http://www.fruita.org); Engineering Documents.

- (A) **Adopted Standards.** All applicable specifications of agencies or organizations listed below are made a portion of these Engineering Specifications by reference and shall be the latest edition or revision thereof. Whenever a conflict exists between any of the above standards, the City Engineer shall decide which shall govern.

A.A.S.H.T.O.	American Association of State Highway and Transportation Officials
A.C.I.	American Concrete Institute
A.D.A	Americans with Disabilities Act regulations
A.I.S.C.	American Institute of Steel Construction
A.M.R.L.	AASHTO Materials Reference Laboratory
A.N.S.I.	American National Standards Institute
A.P.W.A.	American Public Works Association
A.S.A.	American Standards Association
A.T.S.S.A.	American Traffic Safety Services Association
A.S.M.E.	American Society of Mechanical Engineers
A.S.T.M.	American Society of Testing Materials
A.W.W.A.	American Water Works Association
C.C.R.L.	Cement and Concrete Reference Laboratory
C.D.P.H.E.	Colorado Department of Public Health and Environment
C.D.O.T.	Colorado Department of Transportation
F.E.M.A.	Federal Emergency Management Agency
F.H.W.A.	Federal Highway Administration
M.U.T.C.D.	Manual on Uniform Traffic Control Devices
I.T.E.	Institute of Traffic Engineers
U.F.C.	Uniform Fire Code

- (B) **Quality Control.** The Contractor is responsible for quality control of all work performed and shall implement whatever procedures, methods, testing, surveying, and supervision required insuring that the Work conforms to the Construction Plans and Contract Documents. See Chapter 8.

- (C) **Quality Assurance.** The entity responsible (e.g. Developer or general contractor) for administering the construction of public facilities shall provide a quality assurance program. This program shall include systematic inspection and testing of the work and materials during construction to assure the Owner and the City that the Contractor is providing work that is in conformance with the City approved plans and specifications.

## 1.2: Design Policy

- (A) **General.** The City of Fruita shall review and approve the plans and specifications for proposed extensions of, or changes in, street, water, storm, and sanitary sewer systems and to coordinate the approvals of various other City departments and public agencies prior to the beginning of any construction. These design criteria have been compiled to insure that plans and specifications are reviewed and approved on an equal basis, and that uniformity exists in construction of the system.

It is not the intent of these criteria to regulate the design engineer, but instead, to provide guidelines of minimum design values that should be used in normal situations.

All plans and specifications submitted for approval for construction must have been prepared by or under the direct supervision of a Professional Engineer duly registered and licensed to practice engineering in the State of Colorado.

- (B) **Construction Plan Requirements.** All plans submitted to the City for review shall conform to the minimum legibility and quality control requirements of this Section. Any drawing submitted for review, which substantially does not meet this specification, will not be accepted for review.
- (1) All grading, erosion control, drainage, utility, and street plans shall conform to the minimum design criteria set forth in these specifications. Two complete sets of plans, on 24" x 36" sheets, shall be supplied to the City Engineer's Office, through the Community Development Department, for review and comments by the City Engineer and Public Works Director. The schedule of review will comply with the Community Development Office published schedule. Once the plans have been reviewed, "red line" drawings and written comments shall be returned to the submitter for correction of plans.
  - (2) Construction drawings shall contain the information necessary, presented in a clear and legible manner, to construct the utility. The design engineer shall coordinate the location of all proposed water and/or sanitary sewer lines within all existing and proposed road rights-of-way with regard to existing and proposed roads and drainage structures. In addition, coordination shall be made with other appropriate utility companies and agencies with regard to their existing easements, rights-of-way and facilities.
  - (3) Where the possibility of conflicts with existing utilities exists, it shall be the design engineer's responsibility to secure accurate information on the horizontal and vertical location of such utilities through subsurface exploration.

- (C) **Drafting Standards for Paper.** Plans submitted to the Community Development Department shall be direct prints, 24" x 36", in blue-line or black-line. Photocopies or telefacsimile reproductions are not acceptable for plan review, but may be submitted for information or preliminary review purposes.

- (1) All information must be contained within the borders of each sheet, particularly on the plan and profile sheets.
- (2) No photographs, or prints or reproductions of photographs, shall be a part of any construction drawing. Specifically, aerial photography may not be used in the plan views or at any other location.
- (3) All drawings shall be to scale, with scale shown on the drawings.

(D) **Drawings on Electronic Media.** Drawings submitted on electronic media must conform to all the requirements of this Section, and with the following requirements.

- (1) Document must be completely compatible with City of Fruita software.
- (2) Documents created on compatible software should be received in their standard file formats - for example, AutoCAD documents should be received in .DWG format. The Engineer needs to be aware of discrepancies due to different versions of the software; the City Engineer's Office must be able to work with the media received and send out revisions the Engineer can utilize.
- (3) All correspondence is to be received in Microsoft Word format or in standard ASCII format.
- (4) All CAD documents to be received must be in standard AutoDesk – AutoCAD .DWG format. These documents must be free of any third party software restrictions. Restrictions must be purged off the files before sending to the City of Fruita.

(E) **Construction Drawings.** Construction drawings shall consist of the following: The plan should show sufficient adjacent area to give the relationship of new facilities to existing facilities, and show the tie-in points. The plans shall be made from actual field surveys referred to land corners and other official survey control points. Vertical datum for surveys shall be NAVD88. Horizontal control shall be based on the Mesa County Local Coordinate System (MCLCS), GVAA Zone, NAD83 (1992) by a minimum of two coordinate points. All drawings shall reference at least one official Mesa County Survey Monument (MCSM) and explicitly reference coordinates and elevation to NAVD 88 criteria. Traverse closure shall be at least 1:5000. Fences, fire hydrants, manholes, and other constructed improvements shall not be used as the basis of surveys.

- (1) The following shall be shown on each and every page of all final drawings, except for City of Fruita Standard Drawings and Ute Water Standard Drawings:
  - (a) Project Name
  - (b) Owner's name, address, phone number
  - (c) Title Block (right margin of sheet preferred).

- (d) North Arrow: North shall point to the top or to the left margin of the sheet, other details and drawings on the sheet shall be oriented consistently with the North arrow.
- (e) Vertical Scale: 1" = 5' (1" = 10' may be used in areas which have average slopes over 5%).
- (f) Horizontal Scale: minimum, 1" = 50'
- (g) Date and Revisions: The original date of the plans and any subsequent revisions must be shown in the title block.
- (h) Name, address and telephone number of professional engineer or firm.
- (i) Professional Engineer's Seal, Signature and Date.
- (j) A Project Benchmark referenced to NAVD88 shall be shown and the elevation datum shall be called out on each sheet.

(F) **Overall Site Plan.** Development Plans shall contain the following public improvement facilities, features, and components:

- (1) Sanitary Sewer Plan and Profile
- (2) Water Plan and Profile
- (3) Storm Sewer and/or Surface Drainage Plan and Profile
- (4) Street Plan and Profile
- (5) Traffic Control Plan
- (6) Standard Details when Different from City Engineering Specifications
- (7) Erosion Control Plan
- (8) Property Lines
- (9) Street Names and Easements with all Dimensions Including Lot Dimensions
- (10) Existing Utilities and Structures, including existing ponds and basins, if applicable
- (11) Irrigation Plans and Profiles
- (12) Septic Systems (if applicable) including all setbacks

(G) **Development Plan Format.** Development Plans shall contain, as a minimum, the following plan sheets:

- (1) Cover Sheet
- (2) Final Plat (Recorded Document)
- (3) Composite Site Plan or PUD Guide (Recorded Document)
- (4) Utility Composite Plan
- (5) Sanitary Sewer Plan
- (6) Domestic Water Plan
- (7) Street Plan
- (8) Irrigation Plan
- (9) Grading and Drainage Plan
- (10) Storm Water Drainage Plan
- (11) Erosion Control Plan
- (12) City of Fruita Standard Detail Sheets



Other sheets may be necessary, such as Off-site Sewer and Off -Site Streets, and others that may be required by the City Engineer.

- (H) **Field Control.** It is the responsibility of the developer or his representative to survey the proposed installation and set control stakes in accordance with approved plans. Construction of lines will not continue and installations will not be approved where in the opinion of the City Engineer, proper control has not been furnished. The contractor shall be responsible for preserving all permanent bench marks and survey monuments.
- (I) **Easement.** All public utilities and irrigation mains shall be in an easement with a width of at least two times the depth to the invert. All side yard or rear yard easements shall be a minimum of 10 feet in width and located on one side of a property line. “Split” easements (e.g. 5 feet on either side of a lot line) are not acceptable. The 14’ multi-purpose easement is a perpetual requirement and will not be waived. The absence of dry utilities in the easement will not void this requirement.

### **1.3: Construction Policy**

- (A) **Engineered and Approved Plans.** Construction shall be done in accordance with engineered construction plans for the work prepared under the direction of a professional engineer licensed in the State of Colorado and approved by the City. Plans shall conform to the City of Fruita minimum design standards. Plans approved by the City are valid for a period of one year, after which the plans will require a cursory review to verify conformance to current City requirements. Construction of public improvements shall not begin without approved construction plans and a written notice to proceed from the City Engineer.
  - (1) When any change occurs that involves the following design elements, a revised design sheet is required:
    - (a) Change in infrastructure: sanitary sewer, storm drain system, domestic water lines, irrigation lines, streets and sidewalks.
    - (b) Lot grading (Type A or B)
    - (c) Top of foundation (TOF)

The revised design will be submitted prior to field construction of that element commencing.

Those elements that affect the original Grading and Drainage Plan and/or the original Composite Site Plan will require revision of these sheets.

All changes mentioned above will require approval by the City prior to commencing with those changes.

When the Composite Site Plan is revised, the revision sheet, in addition to the City Engineer signature, will be recorded by the City with the Mesa County Clerk and Recorder’s Office.

- (B) **Inspection and Testing.** All construction work for public improvements shall be subject to inspection by the City Engineer. Certain types of construction shall have continuous inspection.
- (1) It shall be the responsibility of the person performing the work to notify the City Engineer that such work is ready for inspection. The City Engineer shall require that every request for inspection be made in a timely fashion. Such request may be in writing or by telephone, at the option of the City Engineer. Certain inspections, such as camera work or proof roll, require a minimum 48 hour notice.
  - (2) It shall be the responsibility of the person requesting inspections required by these Engineering Specifications to provide access to and means for proper inspection of all work. In addition the contractor shall meet with the City Engineer or his authorized representative on location for a Final Inspection. Final inspection shall not take place until street or easement is at final grade and all manholes, valve cover, etc., are brought to final grade.
  - (3) A City Representative who shall have the authority to halt construction when these specifications or standard construction practices are not being adhered to shall inspect all work, including correction work. Whenever any portion of these specifications is violated, the City may order further construction to cease until all deficiencies are corrected. The notice to cease construction shall be in writing (Stop Work Order). If deficiencies are not corrected, performance shall be required of the contractor's surety.
  - (4) The City Engineer may make or require additional inspections of any work as deemed necessary to ascertain compliance with the provisions of these Engineering Specifications and other provisions of the City Code.
- (C) **Pre-Construction Procedures.** One-week prior to commencement of construction, the contractor shall arrange a pre-construction conference with the City Engineer and City Inspector for the following:
- (1) To become familiar with the City of Fruita engineering specifications.
  - (2) To become familiar with City expectations concerning testing requirements and submittals.
  - (3) To become familiar with city expectations concerning erosion control, street cut permits and other permits.
- (D) **As-Built Information.** It is the duty of the Responsible Party to record and document the physical dimensions and any changes on a set of as-built drawings and to certify as to their accuracy. A PLS or PE shall document the following information to certify the construction plans as being constructed as-built.

- (1) Streets:
    - (a) Elevation check at maximum one hundred fifty (150) foot intervals in each flow line along street, at the point of curb return of each radius, and at the center of each cross pan.
    - (b) Elevation at flowlines at each side of storm inlets (inverts).
    - (c) Elevations at all points shown on the cul-de-sac detail, and at the center and high points in the flowlines.
  - (2) Sanitary and Storm Sewers: Preliminary as-builts are required prior to pavement being completed. Preliminary as-builts only require invert elevations and pipe slopes. Final as-builts will require the following:
    - (a) Elevation of inverts at manholes, inlets, and outlets.
    - (b) Pipe diameter, material type, length, and stationing from manholes. All sanitary sewer service connection location information is to be supplied by Contractor to the Responsible Party.
    - (c) Rim elevations on all manholes and drainage inlet structures.
    - (d) Horizontal verification of sewer service line tap locations.
    - (e) Vertical grade of the service line stub-out.
    - (f) Final detention pond volume from cross sections and the final release rates per drainage criteria (PE certification).
  - (3) Potable Water and Irrigation Mains:
    - (a) Horizontal verification of water valves, fire hydrants, and types of material.
    - (b) The locations of all service connections along the main are to be supplied by Contractor to the Responsible Party.
    - (c) As-builts may be field verified by the City and shall be approved by the City prior to initial acceptance by the City.
- (E) **Submittal of As-Built Plans and Documents.** Final “As-Built” plans shall be blue-line or black-line, clear and clean from objectionable background. Electronic files matching the paper copies of the As-Built plans shall consist of both AutoCAD and pdf format drawings. All As-Built documents shall be submitted to the City of Fruita, Engineering Department.

#### **1.4: General Details**

- A. General Notes**
- B. Easement Notes**
- C. Dust Control Notes**
- D. Trench Detail Notes**
- E. Typical Dry Utility Joint Trench Detail Vertical Separation**
- F. Types A and B Lot Drainage**

GENERAL NOTES:

1. NOTES GIVEN HERE SHALL APPLY TO ALL SHEETS.
2. THE CONTRACTOR SHALL NOTIFY THE CITY OF FRUITA 48 HOURS PRIOR TO THE BEGINNING OF CONSTRUCTION, AND SHALL BE RESPONSIBLE FOR OBTAINING THE NECESSARY PERMITS REQUIRED TO PERFORM CONSTRUCTION WITHIN CITY RIGHT-OF-WAY. THE CONTRACTOR SHALL BE SOLELY RESPONSIBLE FOR PROVIDING AND IMPLEMENTING A TRAFFIC CONTROL PLAN FOR ALL CONSTRUCTION ACTIVITIES IN CITY RIGHT-OF-WAY. CONTACT THE PUBLIC WORKS DEPARTMENT AT 858-9558 TO ACQUIRE AN EXCAVATION IN RIGHT-OF-WAY PERMIT AND TO SUBMIT A TRAFFIC CONTROL PLAN.
3. INSTALLATION OF NEW IMPROVEMENTS, INCLUDING MATERIALS, CONSTRUCTION, PERFORMANCE, AND TESTING, SHALL BE IN STRICT ACCORDANCE WITH THE LATEST STANDARDS AND REQUIREMENTS ADOPTED BY THE CITY OF FRUITA. ALL MATERIALS AND WORKMANSHIP SHALL BE SUBJECT TO INSPECTION BY THE CITY OF FRUITA. THE CITY RESERVES THE RIGHT TO ACCEPT OR REJECT ANY SUCH MATERIALS AND WORKMANSHIP THAT DOES NOT CONFORM TO THE CITY OF FRUITA'S STANDARDS AND SPECIFICATIONS.
4. CONTRACTOR SHALL FAMILIARIZE HIS/HERSELF WITH THE GEOTECHNICAL TESTING REQUIREMENTS OF THE CITY OF FRUITA. THE RESULTS OF THE REQUIRED TYPES OF TESTS AND NUMBERS OF PASSING TESTS SHALL BE FURNISHED TO THE CITY FOR VERIFICATION BEFORE FINAL ACCEPTANCE WILL BE GRANTED. ALL FAILING TESTS SHALL BE BROUGHT TO THE IMMEDIATE ATTENTION OF THE CITY ENGINEER OR HIS/HER REPRESENTATIVE, AND RETESTS SHALL BE PERFORMED UNTIL PASSING RESULTS ARE OBTAINED. ALL UTILITY LINES, INCLUDING SERVICE LINES FALLING WITHIN THE PUBLIC RIGHT-OF-WAY OR PUBLIC EASEMENTS SHALL BE TESTED.
5. ONLY MATERIALS ON WHICH A PROCTOR TEST CAN BE PERFORMED AND ACCURATE NUCLEAR DENSITY TESTS CAN BE RUN ARE APPROVED FOR UTILITY TRENCH BACKFILL UNLESS OTHERWISE APPROVED BY THE ENGINEER (FLOWABLE FILL IS ACCEPTABLE).
6. IT IS THE RESPONSIBILITY OF THE CONTRACTOR TO CONTACT THE CITY ENGINEER IN ADVANCE OF REQUIRED INSPECTIONS.
7. THE CONTRACTOR SHALL NOTIFY THE ENGINEER IMMEDIATELY IF SITE CONDITIONS ARE ENCOUNTERED WHICH ARE DIFFERENT THAN AS SHOWN ON THESE DRAWINGS. CONTRACTOR SHALL NOTIFY THE ENGINEER IMMEDIATELY IF SITE CONDITIONS WARRANT A CHANGE IN DESIGN FROM THAT SHOWN ON THESE DRAWINGS.
8. ALIGNMENT, CENTERLINE CURVE DATA, AND STATIONING TO BE VERIFIED FROM APPROVED SUBDIVISION PLAT BEFORE CONSTRUCTION.
9. LOCATIONS OF EXISTING UTILITIES SHOWN ON THESE PLANS ARE APPROXIMATE ONLY. CONTRACTOR IS TO CONTACT AFFECTED UTILITY FOR SPECIFIC LOCATIONS BEFORE DIGGING.
10. PRIOR TO BEGINNING INSTALLATION OF NEW UNDERGROUND UTILITIES SHOWN ON THESE DRAWINGS, THE CONTRACTOR SHALL EXCAVATE (POTHOLE) EXISTING UTILITIES AT ALL CROSSING POINTS TO VERIFY LOCATION AND ELEVATION OF EXISTING UTILITIES TO ENSURE THAT THE CROSSING CAN BE MADE AS SHOWN ON THESE DRAWINGS.
11. NO CONSTRUCTION WORK SHALL BE PERFORMED OUTSIDE OF THE PROJECT OWNER'S PROPERTY BOUNDARY EXCEPT WITHIN CONSTRUCTION EASEMENTS, PERPETUAL EASEMENTS, AND RIGHT-OF-WAY SHOWN ON THESE DRAWINGS. IT SHALL BE THE SOLE RESPONSIBILITY OF THE CONTRACTOR TO OBTAIN LEGAL PERMISSION TO OCCUPY PROPERTY OTHER THAN THE PROJECT SITE IF THE CONTRACTOR DETERMINES THAT ACCESS IS REQUIRED. ANY DAMAGE TO PRIVATE FACILITIES OUTSIDE THESE LIMITS SHALL BE REPAIRED BY THE CONTRACTOR AT NO EXPENSE TO THE OWNER.
12. ALL ROAD CUTS AND CONSTRUCTION ACTIVITIES WITHIN EXISTING ROAD RIGHTS-OF-WAY SHALL BE PERFORMED IN ACCORDANCE WITH THE REQUIREMENTS OF THE AGENCY CONTROLLING THE RIGHT-OF-WAY.
13. ALL SATISFACTORY EXCAVATION FROM EITHER UTILITY OR STREET CONSTRUCTION SHALL BE SPREAD UNIFORMLY ACROSS THE LOTS AS DIRECTED BY THE OWNER OR HIS/HER DESIGNATED REPRESENTATIVE. ALL UNSATISFACTORY OR WASTE MATERIAL INCLUDING VEGETATION, ROOTS, CONCRETE, ROCKS, OR OTHER DEBRIS SHALL BE HAULED FROM THE PROJECT BY THE CONTRACTOR. NO SEPARATE PAY.
14. IT SHALL BE THE SOLE RESPONSIBILITY OF THE CONTRACTOR TO ENSURE THAT ALL CONSTRUCTION WORK IS ACCOMPLISHED IN ACCORDANCE WITH OCCUPATIONAL SAFETY AND HEALTH ADMINISTRATION (OSHA) RULES AND REGULATIONS.
15. ALL QUANTITIES SHOWN ON THESE DRAWINGS ARE ESTIMATES PROVIDED AS AN AID TO BIDDER/CONTRACTOR ONLY. BIDDER/CONTRACTOR SHALL BE RESPONSIBLE FOR SCALING DRAWINGS TO VERIFY QUANTITIES PRIOR TO BIDDING.
16. THE CONTRACTOR SHALL BE RESPONSIBLE FOR PREPARING AND PERMITTING THE STORM WATER MANAGEMENT PLAN FOR DISCHARGES ASSOCIATED WITH CONSTRUCTION ACTIVITY. THE CONTRACTOR SHALL BE RESPONSIBLE FOR COMPLETING AND MAILING THE APPLICATION, PAYING THE PERMIT FEE, PREPARING THE PLAN, IMPLEMENTING THE PLAN, PERFORMING INSPECTIONS AS REQUIRED AND PERFORMING ALL REQUIRED CLOSE OUT ACTIVITIES. CONTACT THE COLORADO DEPARTMENT OF PUBLIC HEALTH AND ENVIRONMENT/WATER QUALITY CONTROL DIVISION AT (303) 692-3500 FOR INFORMATION REGARDING THE STORM WATER MANAGEMENT PLAN PROGRAM.
17. THE CONTRACTOR SHALL BE SOLELY RESPONSIBLE FOR ENSURING THAT WATER SERVICE LINES AND FIRE HYDRANT LEADS MEET THE MINIMUM BURIAL DEPTH ESTABLISHED BY THE ACCEPTING AGENCY FOR INSTALLATIONS CROSSING UNDERNEATH BORROW DITCHES, DRAINAGE DITCHES, DRAINAGE SWALES, AND CANALS.
18. ALL MATERIALS SHALL BE HANDLED AND INSTALLED IN STRICT ACCORDANCE WITH THE MANUFACTURER'S RECOMMENDATIONS.
19. CONTRACTOR SHALL HAVE ONE SIGNED COPY OF PLANS AT THE JOB SITE AT ALL TIMES.

CITY OF FRUITA  
ENGINEERING DEPARTMENT

SCALE  
HORIZONTAL: N/A  
VERTICAL: N/A

REVISION: 2009 STANDARDS REVISION DATE: 3/18/09  
REVISION: \_\_\_\_\_ DATE: \_\_\_\_\_  
REVISION: \_\_\_\_\_ DATE: \_\_\_\_\_

GENERAL NOTES

FILE:  
SHEET: 1.4A

DRAWN BY: CLD  
DATE DRAWN: 5/06  
CHECKED BY: \_\_\_\_\_

EASEMENT NOTES:

1. A CONTINUOUS MULTI-PURPOSE EASEMENT SHALL BE PROVIDED ON BOTH SIDES OF ALL ROAD RIGHTS-OF-WAY. THIS EASEMENT SHALL BE RESERVED FOR PURPOSES INCLUDING, BUT NOT LIMITED TO INSTALLATION AND MAINTENANCE OF PUBLIC UTILITIES, TRAFFIC CONTROL SIGNS AND SIGNALS, STREETScape, STREET TREES AND SPRINKLING SYSTEMS, EARTH RETAINING STRUCTURES AND SURFACE SLOPING OR GRADING REQUIRED FOR STREET CONSTRUCTION. UTILITY COMPANIES AND/OR THE CITY OF FRUITA SHALL NOT BE RESPONSIBLE FOR DAMAGE TO PLANTINGS, IRRIGATION SYSTEMS, FENCES OR OTHER APPURTENANCES LOCATED OR CONSTRUCTED WITHIN THE MULTI-PURPOSE EASEMENT WHEN SUCH DAMAGE RESULTS FROM THE INSTALLATION AND/OR REPAIR OF UTILITIES WITHIN SAID MULTI-PURPOSE EASEMENT.
2. IRRIGATION DISTRIBUTION LINES SHALL BE LOCATED IN A SEPARATE TRENCH LOCATED ON THE HOUSE SIDE OF THE JOINT UTILITY TRENCH, OR AT THE BACK LOT LINE.
3. PROPERTY OWNERS MAY LANDSCAPE THE FULL WIDTH OF THE MULTI-PURPOSE EASEMENTS. SPRINKLING SYSTEMS INSTALLED WITHIN MULTI-PURPOSE EASEMENTS SHALL NOT BE GREATER THAN 18" DEEP.
4. ALL FIRE HYDRANTS AND WATER METERS SHALL REMAIN UNOBSTRUCTED AND ACCESSIBLE AT ALL TIMES. NO FENCES, PLANTINGS, STRUCTURES OR OTHER OBSTACLE SHALL BE LOCATED WITHIN 4' OF ANY FIRE HYDRANT, WATER METER, OR UTILITY PEDESTAL. NO FENCES OR OTHER OBSTRUCTION SHALL BE LOCATED ON THE STREET SIDE OF ANY FIRE HYDRANT OR WATER METER.

CITY OF FRUITA ENGINEERING DEPARTMENT	SCALE HORIZONTAL: N/A VERTICAL: N/A	REVISION: 2009 STANDARDS REVISION REVISION: _____ DATE: 3/18/09 DATE: _____	EASEMENT NOTES	FILE: SHEET: 1.4B	DRAWN BY: CLD DATE DRAWN: 5/06 CHECKED BY: _____
--	---	--	----------------	----------------------	--

FUGITIVE DUST CONTROL NOTES:

1. BEFORE STRIPPING OF THE SITE IN PREPARATION FOR OVERLOT GRADING, THE SURFACE IS TO BE PREWETTED TO CONTROL DUST.
2. ANY STOCKPILES OF STRIPPED MATERIALS ARE TO BE PERIODICALLY SPRAYED WITH WATER OR A CRUSTING AGENT TO STABILIZE POTENTIALLY WIND-BLOWN MATERIAL.
3. HAUL ROADS BOTH INTO AND AROUND THE SITE ARE TO BE SPRAYED AS NEEDED TO SUPPRESS DUST.
4. AS NOTED ON THE SITE-SPECIFIC STORMWATER MANAGEMENT PLAN, OR GRADING AND DRAINAGE PLAN, GRAVEL PADS ARE TO BE CONSTRUCTED AT THE ENTRANCES TO THE SITE TO HELP IN REMOVING MUD FROM THE WHEELS OF HAULAGE TRUCKS BEFORE THEY ENTER CITY STREETS (SEE EROSION CONTROL DETAIL SHEET).
5. TRUCKS HAULING IMPORT FILL MATERIAL ARE TO BE TARPED TO AID IN THE CONTROL OF AIRBORNE DUST.
6. DURING HIGH WIND EVENTS (20 TO 30 MPH SUSTAINED) CONSTRUCTION ACTIVITY SHALL BE LIMITED OR CEASED IF DUST CANNOT BE CONTROLLED BY WETTING.

CITY OF FRUITA  
ENGINEERING DEPARTMENT

SCALE  
HORIZONTAL: N/A  
VERTICAL: N/A

REVISION: 2009 STANDARDS REVISION      DATE: 3/18/09  
REVISION: \_\_\_\_\_      DATE: \_\_\_\_\_  
REVISION: \_\_\_\_\_      DATE: \_\_\_\_\_

DUST CONTROL NOTES

FILE:  
SHEET: 1.4C

DRAWN BY: CLD  
DATE DRAWN: 5/06  
CHECKED BY: \_\_\_\_\_

TRENCH BACKFILL GRADATION TABLE:

PERCENT, PASSING BY WEIGHT			
SIEVE SIZE	PIPE BEDDING & HAUNCHING MATERIAL (TYPE A)	GRANULAR STABILIZATION MATERIAL TYPE B (USE ONLY WHERE SPECIFIED OR IMPORTED BACKFILL MATERIAL)	DIRECTED BY THE CITY OF FRUITA)
4"	---	---	100
2"	---	100	---
1"	100	---	---
#4	---	15 MAX.	---
NO 200	20 MAX.	---	3-20*

ALL BACKFILL MATERIAL SHALL BE PLACED FULL WIDTH IN 12" MAX. LIFTS AND COMPACTED TO THE MIN. RELATIVE DENSITIES SHOWN \*PLASTIC INDEX (PI) SHALL NOT BE MORE THAN 7.

TYPICAL TRENCH DETAIL

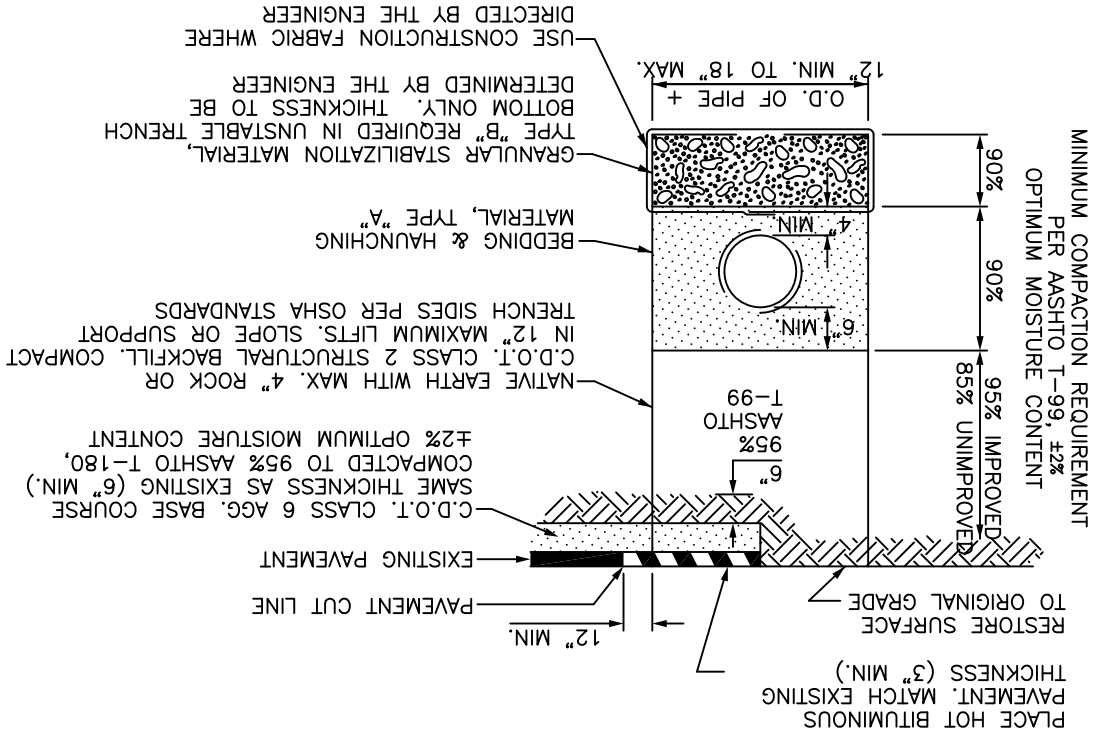





MINIMUM COMPACTION REQUIREMENT  
PER ASHTO T-99, ±2%  
OPTIMUM MOISTURE CONTENT

RESTORE SURFACE TO ORIGINAL GRADE  
PAVEMENT MATCH EXISTING THICKNESS (3" MIN.)  
PLACE HOT BITUMINOUS PAVEMENT MATCH EXISTING THICKNESS (3" MIN.)  
EXISTING PAVEMENT  
PAVEMENT CUT LINE  
12" MIN. offset  
C.D.O.T. CLASS 6 AGG. BASE COURSE COMPACTED TO 95% ASHTO T-180, SAME THICKNESS AS EXISTING (6" MIN.)  
±2% OPTIMUM MOISTURE CONTENT  
NATIVE EARTH WITH MAX. 4" ROCK OR C.D.O.T. CLASS 2 STRUCTURAL BACKFILL, COMPACT IN 12" MAXIMUM LIFTS. SLOPE OR SUPPORT TRENCH SIDES PER OSHA STANDARDS MATERIAL, TYPE "A"  
BEDDING & HAUNCHING  
GRANULAR STABILIZATION MATERIAL, TYPE "B" REQUIRED IN UNSTABLE TRENCH BOTTOM ONLY. THICKNESS TO BE DETERMINED BY THE ENGINEER  
USE CONSTRUCTION FABRIC WHERE DIRECTED BY THE ENGINEER



LEGEND FOR JOINT TRENCH DETAILS

-  ELECTRIC PRIMARY
-  ELECTRIC SECONDARY
-  ELECTRIC SERVICE
-  TELEPHONE AND/OR CABLE TV.
-  GAS PIPE
-  IRRIGATION PIPE (IF APPLICABLE)

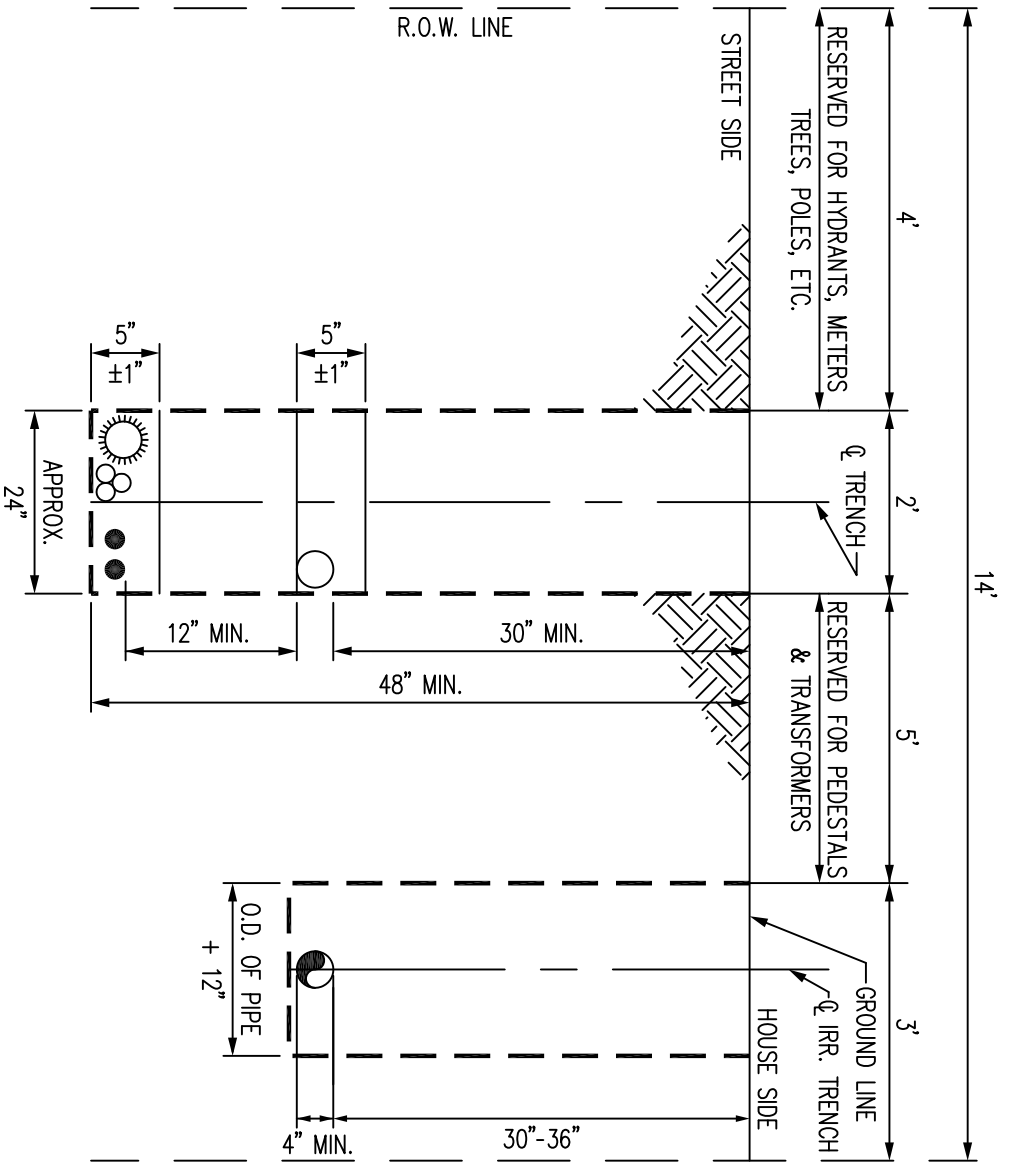

TYPICAL DRY UTILITY

JOINT TRENCH DETAIL

VERTICAL SEPARATION (NTS)

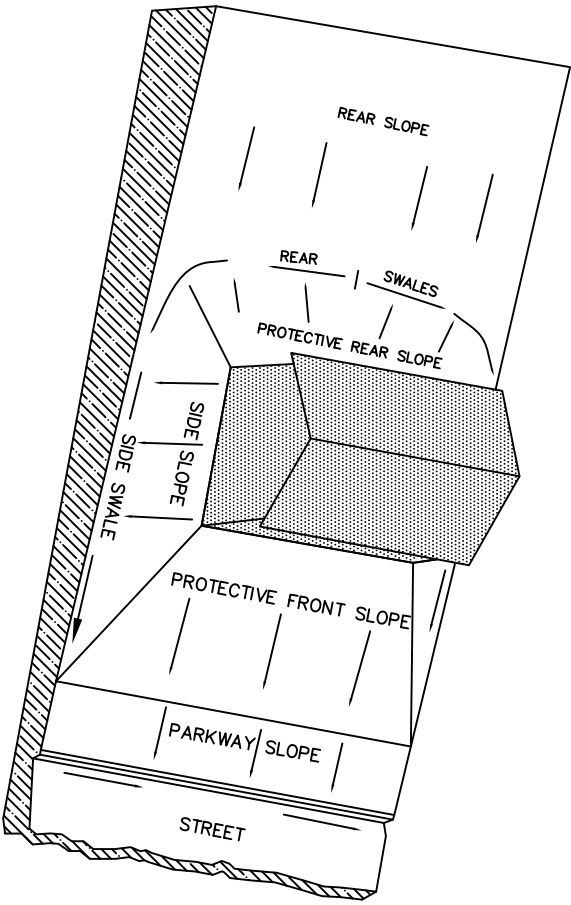

LOT GRADING - TYPE A  
ALL DRAINAGE TO STREET

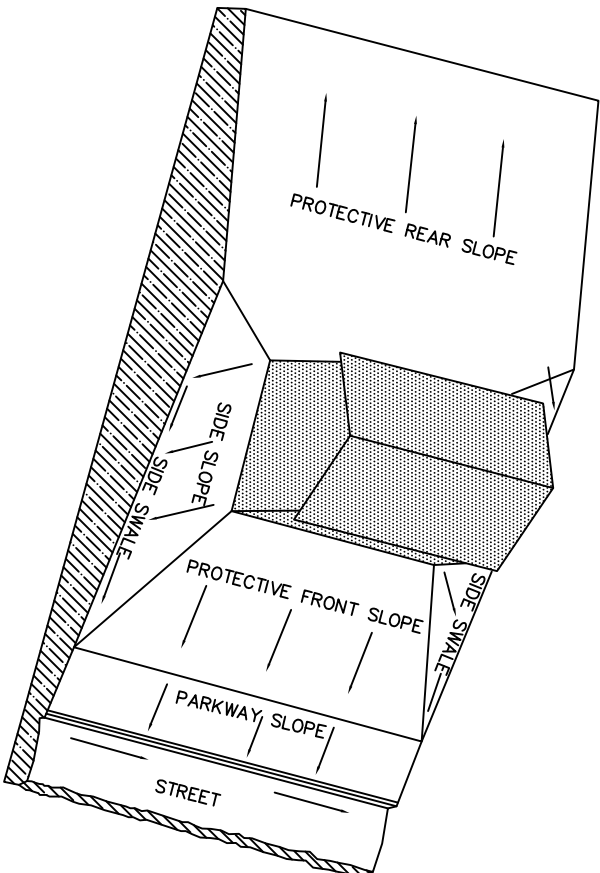

LOT GRADING - TYPE B  
DRAINAGE BOTH TO STREET  
AND TO REAR LOT LINE

CITY OF FRUITA  
ENGINEERING DEPARTMENT

SCALE  
HORIZONTAL: N/A  
VERTICAL: N/A

REVISION: 2009 STANDARDS REVISION  
REVISION: \_\_\_\_\_  
REVISION: \_\_\_\_\_

DATE: 3/18/09  
DATE: \_\_\_\_\_  
DATE: \_\_\_\_\_

TYPES A & B  
LOT DRAINAGE

FILE:  
SHEET: 1.4F

DRAWN BY: CLD  
DATE DRAWN: 5/06  
CHECKED BY: \_\_\_\_\_

## Chapter 2

### WATER DISTRIBUTION SYSTEM STANDARDS

#### Sections:

#### 2.1: General Provisions

#### 2.2: Water Distribution System Design Criteria

#### 2.3: Water Distribution System Construction Specifications

#### 2.1: General Provisions

- (A) **General.** In all respects, the design of the potable water distribution system, and all approval and testing procedures shall be based on the requirements of the Ute Water Conservancy District, and the Lower Valley Fire Department, whichever is more stringent. Irrigation water systems are covered in Chapter 7.
- (B) **Future Extensions.** It should be noted that where it is determined that water lines are necessary to serve property beyond the subdivision or development in question, the developer will be required to design and construct his system, properly sized and at an appropriate location, to permit future extensions to be made at the limits of the subdivision or development in question. The system must terminate, at all points in new development, to within one lot from the adjacent and/or upstream properties to be served by the system in the future. Public water systems must be designed and constructed along major roads and/or through the development to facilitate for future extensions. In selecting routes for water extensions, the City of Fruita requires that the location must be such that it maximizes the potential for serving areas and/or future developments. Requirements for future extensions imposed by the City of Fruita may be greater than those imposed by Ute Water or the Lower Valley Fire District.
- (C) **Quality Control and Quality Assurance.** Quality Control testing shall be in accordance with Chapter 8. Quality Assurance shall be in accordance with Table 1.
- (D) **Coverage.** This section does not apply to untreated water distribution systems such as irrigation systems. See Chapter 7.

**TABLE 2.1 REQUIRED QUALITY ASSURANCE (QA) AND QUALITY CONTROL (QC) TESTING  
City of Fruita, Colorado**

<b>TEST REQUIRED</b>	<b>TEST PROCEDURE</b>	<b>REQUIRED OR ALLOWED RANGE</b>	<b>MINIMUM TEST FREQUENCY</b>
Compaction of bedding and haunching materials (except crushed rock)	AASHTO T 99 and T 238	90% minimum at +/- 2% of optimum moisture. (see notes)	1 per 400 L.F. of trench (and each branch or section of trench less than 400 feet in length) for each two foot vertical depth of backfill material.
Trench Compaction to subgrade  1. Within right of way.  2. In unimproved areas outside of right of way or within landscaped areas.	AASHTO T 99 and T 238	95% compaction minimum at +/- 2% of optimum moisture. (see notes)  85% compaction minimum	
Compaction of aggregate base course material*	AASHTO T 180 and T 238	95% compaction minimum at +/- 2% of optimum moisture*. (see notes)	1 per 300 S.Y.
Compaction of subgrade within 24" of all structures ( <b>manholes, catch basins, valves, vaults, etc.</b> )	AASHTO T 99 and T 238	95% compaction minimum at +/- 2% of optimum moisture. (see notes)	1 per each two-foot vertical depth of backfill material or per 100 L.F. of structure perimeter
Flowfill	Mix design	50 psi to 200 psi	Submit mix design prior to use.
Compaction of rock, pit run, or other material that cannot be tested by normal procedures.	Field Inspection / Method Specification	Minimum 3 passes with wheeled compactor (smooth drum, vibratory, sheepsfoot or 4 passes with plate compactor.	Field / full time inspection only. Trenches at discretion of Engineering.

Notes:

If minimum moisture density requirements are not met by these tests, the contractor shall recompact the trench as needed to achieve the specified compaction. Such recompaction shall extend both upstream and downstream of the failed test section a distance equal to 1/2 the distance from where the last test was taken or 165 ft., whichever is least. An alternative procedure would be to more clearly define the limits of the failed area by additional tests.

For unpaved travel surfaces, (gravel, recycled asphalt, etc,) all material within 12" of finish road surface shall be compacted to 95% minimum of AASHTO T180.

\*Regarding compaction of aggregate base course material – Moisture requirements may be adjusted at the discretion of the City Of Fruita.

Engineer and/or contractor shall verify that the latest edition of AASHTO specifications are referenced.

A minimum of one test will be required for any portion of the material less than that shown in the "Minimum Test Frequency" column, unless otherwise approved by the City inspector.

## 2.2: Water Distribution System Design Criteria

(A) **General.** The latest edition of the Ute Water Standard Specifications for water line construction, published by Ute Water Conservancy District, must be adhered to. The following are City guidelines. In the event the City guidelines conflict with Ute Water specifications, the Ute Water specifications will prevail.

(B) **Water Line Location.** Generally, water lines to be installed in proposed subdivisions and local streets shall be located in the east or north side of streets, no more than 6 feet or less than 3 feet west or south respectively, from the edge of the asphalt.

Where water lines are to be installed in roads expected to be widened in the future, they shall be located in easements unless the future road cross section is known and location of water line is designed to avoid future relocation.

(1) Within Subdivision Easements: In subdivisions, water mains will be permitted in easements only when there is no other feasible alternative and prior approval is obtained from the City Engineer and Ute Water. Easements shall be a minimum of 30 feet wide and located within an open space tract or outlot.

(2) Existing Systems and Structures: The engineer shall consider the location of existing and proposed sanitary sewer and storm drainage systems and all other underground structures and utilities that could affect the location and type of materials for the pipeline. The selected location should avoid conflicts and facilitate future maintenance. Where the possibility of conflicts with existing utilities and/or other structures exists, it shall be the engineer's responsibility to secure accurate information on the exact horizontal and vertical location of such utilities through subsurface exploration and reflect this exact information on the plans. In the case of unavoidable conflicts, the water line shall be relocated as opposed to making design changes to sanitary sewers or storm drains.

(3) Separation Standards: The engineer shall consider the requirement for separation of water and sanitary sewer facilities and shall use the same requirements stated in section 3.2 (C), Sanitary Sewer System Standards, Sewer Line Separation Requirements, and section 2.2 (G) of this chapter.

(C) **Water Line Depth.** Refer to Ute Water Standard Specifications.

(D) **Water Line Appurtenances.**

(1) Fire Hydrants. Hydrants in residential areas should be located at the corner of a street intersection or in mid-block at lot lines as approved by the Lower Valley Fire District. Circular street alignments will require fire hydrants placed at a maximum interval of 500 feet along the street between intersecting streets, and no more than 250 feet to any house. When cul-de-sacs are longer than 250', the last fire hydrant shall be designed immediately before the bulb of the cul-de-sac, where practical. The developer is to make the necessary

improvements to the system to satisfy fire flow demands as determined and required by the Lower Valley Fire District. The distance from the center of the fire hydrant pumper connection nut to the finished grade shall not be less than 22 inches. Pumper connections shall face the street or as directed by the Fire Chief.

(2) Valves. Valves shall be located at not over 400 foot intervals and at all changes in pipe diameter. Valves shall also be provided at all pipe line intersections so as to provide shut off for repairs of limited sections without interruption of service to large areas and to facilitate testing. A minimum of two valves shall be provided at tees, three valves at crosses. All valves are to be restrained to fittings by approved method. Valves shall be placed at each fire hydrant and permanent blow-off.

(E) **Structural Design.** Structural requirements must be considered in the design of all water mains and appurtenances. This is a matter of detail design and is not subject to simple generalization. The design engineer should consider the following criteria:

(1) Special Structures. Structures shall be built as shown in the standard details. However, structures other than those shown in the standard details shall be considered special structures and shall be designed and detailed by the design engineer and submitted for review and approval to the City Engineer and Ute Water District Engineer prior to plan submittal or brought to the department's attention at the time of plan submittal.

(F) **Pipe and Fittings for Water Mains and Service Connections.** Refer to Ute Water Standard Specifications.

(G) **Relationship between Water Lines and Sewer Lines.** The physical relationship between water lines and sanitary sewer lines shall conform to the requirements of the Colorado State Department of Health. The minimum horizontal spacing between sewer lines and water lines shall be ten (10) feet measured centerline to centerline.

(1) When the sewer crosses under the water pipe with less than 18 inches separation the sewer line shall be encased (3.8.C) with fiber reinforced concrete a distance of 10 feet on each side of the water line as shown on the Ute Water Standard Detail Sheet and City of Fruita Standard Detail Sheet.

(2) When the sewer line crosses over the water pipe, no matter what the vertical distance, the sewer line shall be encased with fiber reinforced concrete to a distance of 10 feet on each side of the water line as shown on the City of Fruita Standard Detail Sheet.

## **2.3: Water Distribution System Construction Specifications**

(A) **General.** Construction Standards shall comply with Ute Water specifications.

(B) **Tracer Wire.** Water main lines and service lines must be installed with tracer wire.

## Chapter 3

### SANITARY SEWER SYSTEM STANDARDS

#### Sections:

- 3.1: General Provisions
- 3.2: Sanitary Sewer System Design Criteria
- 3.3: Sanitary Sewer Material Specifications for Pipe, Pumps and Fittings
- 3.4: Sanitary Sewer System Installation Specifications
- 3.5: Accessory Dwelling Units
- 3.6: Excavation, Backfill Removals and Restoration Specifications
- 3.7: Sanitary Sewer Pipeline Testing
- 3.8: Final Inspection and Acceptance
- 3.9: Sanitary Sewer System Details

#### 3.1: General Provisions

- (A) **General.** A Registered Professional Engineer licensed to practice in the State of Colorado shall design all sanitary sewer systems.
- (B) **Future Extensions.** The on-site system must extend to the exterior limits of the subdivision where adjacent or upstream properties may be adequately served in the future.

Public sanitary sewer collection systems must be designed and constructed along major streets (often referred to as off-site systems) and through the development (often referred to as on-site system) to facilitate future extensions. The construction on the major streets (generally classed as collectors) shall extend along the full street frontage of the subdivision.

- (C) **Materials.** All materials used shall be new and in conformance with the applicable standards.

- (1) **Material Requirements:** All materials shall conform to the requirements of these specifications. The type, size and strength class of pipe, fittings and other materials shall be as shown on the Construction Drawings and in sections 3.9A and B.

- (2) **Inspection and Testing:** All pipes shall be tested in conformance with the applicable standards. Testing may be witnessed by the Engineer's representative, or by an approved independent testing laboratory. Upon request of the Engineer, the Contractor shall provide a copy of certified test reports to the City indicating that material does conform to the applicable standards or specifications.
- (3) **Handling:** All materials shall be handled with equipment and methods adequate to prevent shock or damage. Under no circumstances shall materials be dropped. Pipe handled on skid ways shall not be skidded or rolled against pipe already on the ground. If any part of the coating or lining is damaged, the Contractor shall repair or replace the material at his expense as directed by the Engineer.
- (4) **Storage:** The Contractor will be held responsible for the safe storage and protection of all pipe and other materials delivered to the work site. The interiors of all pipe and fittings shall be kept free from dirt and foreign matter at all times. Gaskets for pipe joints shall be stored in a cool location out of direct sunlight. If sunburned pipe is utilized, the City requires that the contractor provide a manufacturer's certification that all warranties are still valid. The City reserves the right to reject sunburned pipe depending on the severity of the apparent damage. Any material that has been damaged before actual incorporation in the Work shall be repaired or replaced at the Contractor's expense.

### **3.2: Sanitary Sewer System Design Criteria**

- (A) **General.** In cases where sanitary sewers are to be constructed on steep grades and velocities greater than 15 feet per second are indicated, solid wall PVC pipe or other abrasion resistant material shall be used. Clay dams shall be utilized where the possibility exists that ground or surface water will follow the sewer trench, causing damage or undermining of pipe bedding.

Sanitary sewers shall remain fully operational during the 100-year flood. Sewers and their appurtenances located along streams shall be protected against the normal range of high and low water conditions, including the 100-year flood. Watertight manhole lids and watertight joints may be required. Sewers located along streams shall be located outside of the streambed and sufficiently removed from there to provide for future possible channel widening. The provision of section 3.7 Sanitary Sewer Pipeline Testing shall pertain to this section.

- (B) **Location of Sanitary Sewer Lines.** All sanitary sewers shall be located in proposed streets 6-feet west or south of the street centerline. Mains that are installed in alleys shall ordinarily be located in the center of the alley. Mains not located in streets or alleys shall be located in tracts or outlots having a minimum width of 20'. All sewer mains and manholes shall have unrestricted all weather access provided for City maintenance



equipment and crews. Said access shall have a minimum width of 20' with all-weather traffic lane of minimum 12'. Exceptions to this specified location will be allowed only when it has been definitely shown that it is not practicable to adhere to the standard location. All sanitary sewers shall be laid on a straight line, horizontally and vertically, between manholes.

(C) **Sewer Line Separation Requirements.**

- (1) **Horizontal separation:** Sanitary sewer main and manholes shall be installed a minimum of 10-feet horizontally from any water main. The distance shall be measured edge to edge between affected lines. Any variations shall be approved by the water utility company.
- (2) **Vertical separation:** There are two conditions of vertical separation of sanitary sewer mains from water mains:
  - (a) Where the water main is less than 18-inches above the sewer main, full fiber reinforced concrete encasement of the sewer main is required. The encasement shall extend ten (10) feet each side of the crossing point. Refer to the Standard Drawings for further details.
  - (b) Where the water main is below the sewer main, **regardless of vertical separation**, full fiber reinforcement concrete encasement of the sewer main is required. The encasement shall extend ten (10) feet each side of the crossing point. Refer to the Standard Drawings for further details.
- (3) Where the sanitary sewer is installed parallel to a storm drainage structure, there shall be at least 6 feet horizontally, measured center to center, between them.
- (4) Ductile iron pipe (Class 52) shall be used when crossing storm sewer and other rigid underground conduits when the vertical separation is 18" or less. Concrete encasement of the sewer pipe is an option.

(D) **Sewer Lines Installed within Borings.** Carrier pipe within bores for sanitary sewer installation shall meet CDOT specifications for crushability.

(E) **Sewer Lines at Railroad Crossings.** All sanitary sewer line crossings of railroads and, where required, roadways, and other major structures shall be encased in a carrier pipe. Design of railroad crossings shall comply with the requirements of Union Pacific Railroad, Utilities Installation Procedures. The engineer shall be responsible for the preparation of the necessary application, in advance of construction or advertisement for bid, for submission by the City to the railroad or in a timely fashion as determined by the City Engineer.

- (F) **Sewer Lines at Stream Crossings.** The tops of all sewers entering or crossing streams shall be a sufficient depth below the natural bottom of the streambed to protect the sewer line. In general, two feet of suitable cover shall be provided where the stream is located in rock and three feet of suitable cover in other material. Less cover will be considered if the proposed sewer crossing is encased in concrete or ductile iron pipe carrier is used and will not interfere with future improvements to the stream channel.

Sewers entering or crossing streams, estuaries, lakes, or reservoirs shall be constructed of watertight pipe. The pipe and joints shall be tested in place and shall exhibit zero infiltration. Sewers placed on piers across ravines or streams shall be allowed only when it can be demonstrated that no other practical alternative exists. Such sewers on piers shall be constructed in accordance with the requirements for sewers entering or crossing under streams. Construction methods and materials of construction shall be such that sewers will remain watertight and free from change in alignment or grade due to anticipated hydraulic and physical loads, erosion and impact.

- (G) **Depth of Sanitary Sewer Lines.** All sewer mains and service lines within the street ROW shall be designed so that a minimum of four (4) feet of cover exists over the pipe after final grade has been established, unless specifically approved by the City Engineer.

Sewer mains and service lines within the street ROW which have less than four (4) feet of cover or more than twenty (20) feet of cover shall be installed using PVC pressure pipe, as specified in subsection 3.3 (C). Under no circumstances shall a sewer have less than three (3) feet of coverage, unless specifically approved by the City Engineer in writing. Sewer lines, which must cross under irrigation ditches or through bogs or swamps where the soil is unstable and water infiltration may be high, must be specifically designed by the consulting engineer and approved by the City.

- (H) **Sanitary Sewer Manholes.** Manholes shall be constructed in accordance with City of Fruita Standard Specifications for Construction of Underground Utilities and Standard Sanitary Sewer Details. The diameter of manholes shall be three feet plus the diameter of the largest pipe, or a minimum of four feet. Refer to section 3.9D.

Manholes shall be located at the end of each line; at all changes in pipe size, alignment and grade and at sewer junctions. Service lines larger than 4-inch diameter and serving more than two residential units must have a manhole at the main line to make the connection. Maximum spacing between manholes on straight runs shall be 450 feet.

All standard manholes shall have a minimum 0.2 ft. drop from invert-in to invert-out, unless approved by the City and specifically called out on the approved Construction Plans. Exceptions to this requirement are found in Section 3.3 F (3), F (4) and 3.4 H.

Manholes subject to flooding shall be easily accessible and have watertight manhole covers.

- (I) **Drop Manholes.** Drop manholes shall be used when the spring line elevation of the incoming sewer line exceeds the spring line elevation of the outgoing sewer line by 2' or more. For additional information refer to Section 3.3 F (6).
- (J) **Sampling Manholes.** Sampling manholes shall be installed at all commercial facilities located within business parks and industrial parks which includes but not limited to industrial facilities, food processing, metal processing, hospitals, dental facilities, animal hospitals, photographic finishers, printing shops, or any facility that the City feels may have an impact on the wastewater treatment plant.
- (1) Physical design of the sampling point must be appropriate for the type of wastewater to be sampled. Manhole shall be located within fifteen feet (15') of the building and shall be accessible by City personnel at all times.
  - (2) For further information, contact the City Public Works Department.
- (K) **Service Connections.** Service connections shall be provided in accordance with existing City specifications and details. Plugged service connections at full-body wyes are to be provided for all lots and parcels. The service line shall be extended to the house side of the multi-purpose easement, utility easement or ROW line where no easement exists. A minimum size of 4-inch diameter pipe is required for residential subdivisions. Each dwelling unit is required to have a minimum 4" service line. As an example, a duplex unit will have two 4" service lines. Multi-family dwellings shall have a 6" minimum service line. Commercial and industrial developments will have a minimum 6" service line to each lot, unless directed otherwise by the City. Manholes shall be used to connect service lines to main lines when the service line is larger than 4 inches, unless otherwise approved by the City.

Sewer service pipe within the public way shall be laid at a minimum grade of one-fourth (1/4) inch per linear foot unless otherwise approved by the City Engineer. Flatter slopes between one-eighth (1/8) and one-fourth (1/4) inch will be allowed only when there is not enough elevation difference to achieve one-fourth (1/4) inch per foot. Installation of service lines at less than 1/4 inch per foot must be pre-approved by the City and/or be designated on approved construction plans.

All 4-inch service lines shall be joined to the new sewer mains with a wye fitting. A 1/8 bend, and other fittings may be required for alignment. Unless approved in writing by the City Engineer or Public Works Director, the invert elevation of the 4-inch and 1/8 bend shall be equal to or greater than the inside crown elevation of the sewer main. Generally, the wye fitting must be placed such that the 4-inch connecting leg is at a 45-60 degree angle to the horizontal plane in order to comply with this specification. Refer to the Standard Drawings for additional details. The invert of the 6-inch line shall be placed above the springline of the main line so that flow from the main line does not back into the service line. For taps into existing clay or concrete sewer lines, tapping saddles are preferable

because they install better. However “Inserta-tees” manufactured by Inserta Fittings Company of Hillsboro, Oregon (503-357-2110) or approved equal are acceptable and will be used in accordance with the manufacturer’s specifications. For existing PVC mains, “Inserta-tees” are preferred, but tapping saddles may be used.

For the installation of sewer service lines to properties that will not be immediately connecting or reconnecting to the sewer system, the service lines shall be stubbed out to the house side of the multi-purpose easement, utility easement or right-of-way line where no easement exists.

Where a PVC sewer line is connected to an existing line, the connection shall be made with a Calder coupling, or approved equal, of the style or with the adapters to be compatible with the pipes being joined

All service lines will have a cleanout installed in accordance with the Uniform Plumbing Code. When the clean-outs are within a right-of-way, the cleanouts shall be enclosed in a 24-inch diameter concrete barrel with a standard ring and cover suitable for traffic loads.

Sub-drains and/or French drains will not be permitted to connect to sanitary sewers.

Services for service stations, car washes and food-processing establishments shall have a grease and/or sand trap installed on their service lines. The trap shall be constructed to the requirements shown on the City of Fruita Miscellaneous Details Sheet.

All service lines must have tracer wire installed. Besides having the tracer installed, the wire must be brought up in an accessible manner. At the point where the wire is tied into the main line, if there is not already tracer on the main line, or the line ends, the wire must be grounded; and the wires will be required to be tested to insure the wire has continuity.

(L) **Structural Design.** Structural requirements must be considered in the design of all sanitary sewers and appurtenances. This is a matter of detail design and is not subject to simple generalization. The design engineer should consider the following criteria:

- (1) **Special Structures.** Whenever possible sanitary sewer structures shall be built as shown in the *Sanitary Sewer System Details*. Structures other than those shown in the *Sanitary Sewer System Details* shall be considered special structures and shall be designed and detailed by the design engineer.
- (2) **Pipe Foundation.** In all cases the proper strength sewer pipe shall be specified for the proposed depth, width of trench and bedding condition. Soil condition should be considered with samples being obtained where necessary to verify pipe selection and foundation design.

(M) **Hydraulic Design for Sanitary Sewers.** In general, the pipe diameter should be continually increasing with increase in tributary flow. Where steep ground slopes make

possible the use of a reduced pipe size and substantial economy of construction costs is thereby indicated, the pipe size may be reduced, but due hydraulic allowances shall be made to provide for head loss at entry, increased velocity, and effect of velocity retardation at the lower end where the flow will be on flatter slopes. In no case, should pipe sizes be thus reduced more than one nominal size in diameter.

If required, hydraulic computations shall be submitted to the City for approval. The developer's engineer shall submit with all sewer plans the information and calculations on sewer flow demands for the project. Upon receiving a written request from the developer and/or his agent and the information furnished by the developer's engineer, the City will then provide the available sewer capacity. After evaluating this information on available capacities, the engineer shall then furnish his calculations supporting that these demands can be met and that the sizing of the proposed sewer mains is adequate. The quantity of sewage for design purpose shall be determined by the future requirements of the total drainage area tributary to the section of sewer under consideration.

- (1) Average quantities of sewage, including allowable infiltration, shall be computed as follows:

	<b>Gallons per day per acre</b>	<b>Equivalent Persons/Acre</b>
<b>Residential</b>		
Low Density (1.0-3.0 dwellings per acre)	500	5
Medium Density (3.1-7.0 dwelling units per acre)	1,000	10
High Density (7.1+ dwelling units per acre)	2,500	25
<b>Other</b>		
Agriculture/Undeveloped Land	1,000	10
	<b>Gallons per day per acre</b>	<b>Equivalent Persons/Acre</b>
<b>Commercial</b>		
Business	2,000	20
Regional/Commercial	2,500	25
<b>Industrial</b>		
Light	2,500	25
General	3,500	35

- (2) Where site-specific determinations can be made, sewage flows may be determined by using the following design information:

<b>Discharge Facility</b>	<b>Design Units</b>	<b>Flow gpd</b>
Residential Units		
a) Single Family Units Includes Townhouses, Individual House Trailers	3.5 people/dwelling	194/unit
(b) Apartments and Condominiums		194/unit
Schools with showers and cafeteria		
Elementary	Per person	16
High School	Per Person	25
<b>Discharge Facility</b>	<b>Design Units</b>	<b>Flow gpd</b>
Motels and Hotels – rooms only	Per person	130
Restaurants	Per seat	50
Service Stations	Per vehicle serviced	10
Factories	Per person/8 hr shift	25
Shopping Centers	Per 1000 sq ft of Ultimate Floor space	250
Hospitals	Per bed	300
Nursing Homes	Per bed	200
Homes for the Aged	Per bed	100
Doctors Office in Medical Center	Per 1000 sq ft	500
Laundromats, 9 to 12 machines	Per machine	500
Theaters, Auditorium Type	Per seat	5
Bowling Alleys	Per lane	75
Office Buildings	1000 sq ft ultimate floor space	200

(3) Design flow shall be calculated using Colorado Department of Public Health and Environmental criteria. The engineer should insure that the following design criteria are adhered to:

- (a) For design calculations, design @  $\frac{3}{4}$  pipe depth;  $q=90\%$  pipe flowing full;  $d=3/4D$ ;  $v=114\%$  full pipe velocity (V)

- (b) Sewers shall have a continuous slope, straight alignment and uniform pipe material between manholes.
- (c) At all manhole junctions where a smaller diameter sewer main discharges into a larger sewer main and at all locations where the line increases in size, the invert of the larger sewer main shall be set so that the energy gradients of the sewers at the junction are at the same level. Generally, this condition will be met by placing the pipes at crown's level where possible. However, as a minimum, place the 80% depth of flow in each sewer at the same elevation.
- (d) Sewers shall be designed to be free flowing with the hydraulic grade below the crown and with hydraulic slopes sufficient to provide an average velocity, when flowing full, of not less than 2.25 feet per second. Computations of velocity or flow rate shall be based on a value of "n" = 0.013 as used in the Kutter or Manning formula.
- (e) In cases where the calculated depth of flow is less than the pipe flowing full, the velocity at actual depth of flow should be computed.
- (f) Hydraulic design capacity shall be based on peak flow rate, 2.5 Peaking Factor.

(4) For sewage flow depth less than 1/4 full, allowance should be made for increased value of "n". In no case should velocities of less than 1.3 feet per second be permitted. Increased velocities shall be accomplished by steeper grades.

(5) The following are **minimum slopes** in feet per hundred feet to be provided for pipes flowing 1/4 of full depth to full depth:

Pipe Size	4"	6"	8"	10"	12"	15"	18"	21"	24"	27"	30"	36"
Slope %	2.0	.64	.40	.29	.23	.15	.12	.10	.08	.067	.058	.046

A minimum slope of 0.50% shall be maintained for terminal 8" lines not likely to be extended, including cul-de-sacs.

4" service lines require a range of 1/8-1/4 inch per foot. Less than 1/4 inch requires City approval.

6" service lines require a minimum of 3/32 inch per foot.

Minimum pipe size between manholes shall be 8".

(6) In cases where sewers are to be constructed on steep grades for which high velocities are indicated, the maximum permissible velocity at **average flow** (before applying peak flow factor) **shall not exceed 15 feet per second**. Suitable drop manholes shall be provided to break the steep slopes and to limit velocities to not more than 15 feet per

second in the connecting sewer pipes between manholes. Standard manholes may be used where the vertical distance between flowline of inverts in and inverts out does not exceed 2 feet.

Where drop manholes are impracticable for reduction of high velocity, the sewer shall be of solid wall PVC pipe or other abrasion resistant material.

(7) Head Losses: Miscellaneous head losses at manholes, curves and junctions shall be estimated and allowed for as follows:

- (a) At manholes on straight runs allow head loss = 0.05 feet.
- (b) 90° turns made inside of manholes, where the radius of turn is less than 2 pipe diameters allow  $0.50 V^2/2g$ . If the radius of turn is greater than 2 pipe diameters, allow  $0.25 V^2/2g$ . In no case should the total allowance be less than 0.05 ft.
- (c) At transitions and intersections of sewers larger than 24" in diameter, allow  $0.50 V^2/2g$ .

- (N) **Commercial/Industrial Development.** Each suite\*\* within a commercial building shall be provided with an individual service line. A cleanout shall also be provided on each service line outside and near the exterior building perimeter wall. The service line may be 6 inches or larger unless otherwise approved by the Public Works Department. A 6 inch or larger service line requires the use of a manhole to tie into the main sanitary sewer line. A sampling vault may be acceptable in lieu of the manhole if approved by the Public Works Department. Restaurants and other food service establishments, vehicle maintenance facilities, and other facilities (at the discretion of the Public Works Director) shall install and maintain a commercial grease trap or sand/oil interceptor external to the building, and prior to the connection to the City main. Refer to City of Fruita Sanitary Sewer Standard Detail Sheet and section 3.9K, 3.9L.

\*\*Separate business space within the same building.

### 3.3: Sanitary Sewer Material Specifications for Pipe, Pumps, and Fittings

- (A) **General Specifications.** Pipe used in construction of gravity sanitary sewer mains and service lines shall be polyvinyl chloride (PVC). Sanitary sewers under pressure shall be PVC pipe and shall meet the requirements of ASTM D-2241 (IPS) or AWWA C-900.

The minimum pipe size for gravity sewers shall be 8" diameter for mains and laterals, and 4" diameter for service lines for residential and 6" for commercial unless otherwise approved. Service taps for new construction shall be accomplished utilizing a full-body wye fitting. For taps into existing clay or concrete sewer lines, tapping saddles are preferable because they install better. However "Inserta-tees" manufactured by Inserta Fittings Company of Hillsboro, Oregon (503-357-2110) or approved equal are acceptable



and will be used in accordance with the manufacturer's specifications. For existing PVC mains, "Inserta-tees" are preferred, but tapping saddles may be used.

- (B) **PVC Gravity Sewer Pipe.** PVC sewer pipe and fittings shall conform to ASTM D-3034 Type PSM for diameters 4" to 15" and to ASTM F-679 Type I for diameters 18" to 27". The minimum wall thickness for PVC pipe shall conform to Standard Dimension Ratio (SDR) 35. Joints shall be bell-and-spigot type with flexible elastomeric seals conforming to ASTM D-3212 and shall not be longer than 13 feet in length. Gaskets shall be neoprene or other synthetic rubber material conforming to ASTM F-477. The bells shall be integrally formed with the pipe or fitting.
- (1) PVC Sewer Pipe and Profile Wall Pipe for Storm Drains, Low Head Irrigation Systems and Underdrains: PVC Sewer Pipe and fittings and PVC profile wall pipe and fittings shall meet the requirements of subsection (B) above.
  - (2) Ribbed PVC pipe may be used for sizes 15" through 30". Ribbed PVC sewer pipe shall be seamless open profile and meet the requirements of ASTM F-794 and Uni-Bell UNI-B-9. Pipe shall have a smooth interior with a solid cross-sectional rib exterior. Exterior ribs shall be perpendicular to the axis of the pipe to allow placement of the sealing gasket without additional cutting or machining. The pipe stiffness shall be a minimum of 46 psi when tested at 5% deflection in accordance with ASTM D-2412.
- (C) **PVC Pressure Sewer Pipe.** PVC pipe used for sanitary sewers under pressure shall meet the requirements of ASTM D-2241 (IPS) or AWWA C-900. Joints shall conform to ASTM D-3139 and have elastomeric seals conforming to ASTM F-477. The type and pressure class shall be as shown on the Construction Drawings.
- (1) Fittings: PVC pipe fittings shall be fabricated of PVC material having a pressure rating equal to or greater than the pipeline used. PVC fittings may be used only with PVC pipe. When used with AWWA C-900 PVC pipe, sizes 4" through 8", the PVC fitting shall conform to AWWA C-907. When used with ASTM D-2241 pipe, the PVC fitting shall be of the same or higher class as the pipe and the pipe rating shall be reduced by 50%.
- (D) **Individual Lift Pumps.** Low pressure sewer services incorporating lift pumps at each house are not allowed without the specific written approval of the City. The required submittal information for review includes force main depth; pipe type and location, particularly within City ROW; and information on the pumps, controls, enclosure, wet well and piping. If approved the facilities shall be installed in accordance with applicable City of Fruita *Sanitary Sewer Standard Details*.
- (E) **Collection System Lift Pumps.** All lift pumps located on the City owned collection system shall be approved by the Public Works Director, City Engineer and the Colorado Department of Health, and shall become the property of the City of Fruita upon approval of the installation. A typical drawing and the minimum requirements are found in section 3.9N thru 3.9P.

(F) **Manholes for Sanitary Sewers and Storm Drains.** Manholes shall be constructed as shown on applicable City of Fruita *Sanitary Sewer Standard Details* and sections 3.9D, 3.9E, and 3.9F.

- (1) **Cement:** All cement used in mortar, concrete bases and precast manhole riser sections, cones and flat tops, for sanitary sewer manholes, shall be Type V or modified Type II Portland cement having less than five (5) percent tricalcium aluminate.
- (2) **Precast Concrete Manhole Sections:** Manhole risers, cones, flat tops and grade rings shall be precast reinforced concrete sections conforming to ASTM C-478 or AASHTO M-199. Manhole risers, cones and flat tops shall be made with tongue and groove ends for continuous and uniform joints between sections. The joint sealant shall be a flexible, preformed, bitumastic joint sealant.
- (3) **Through Manhole:** Sanitary sewer manholes having no side flow inputs may be constructed as a through manhole, with pipe placed continuously through the manhole providing a PVC invert. Minimum fall across the manhole shall match the slope of the pipe. The concrete invert of the manhole shall have a steel trowel finish free of transverse or longitudinal trowel marks. Broom finishes are not acceptable. If not cast-in-place, the space between the pipe and the concrete invert shall be filled with a non-shrink grout. The top of the PVC pipe shall be cut out along the spring line for the complete width of the manhole inside diameter.
- (4) **Epoxy Gel Inverts:** In the event that 0.2 feet of positive fall can not be maintained across standard manholes, the manhole invert shall be coated with an epoxy gel material suitable for feathering and vertical application. Use this method specifically for manholes where 0.2 feet drop cannot be met, but where side flows are needed. Side flow lines will meet the 0.2 feet drop at invert. Main line will be flow through.

The epoxy product shall meet, at a minimum, the following specification:

ASTM C-881, Type I, II, IV and V, Grade 2, Classes B & C	
Mix Ratio	1 Part A to 1 Part B by Volume
Color	Grey
Viscosity	2450 cps
Gel Time	6 to 8 minutes at 75 degrees F
Cure	2 hours
Compressive Strength	ASTM D-695: 10,100 psi at 7 days
Concrete Bond Strength	ASTM C-882: 2,500 psi at 2 days; 2,850 psi at 14 days;
Modulus of Elasticity	ASTM D695 339,000 psi
Water Absorption	ASTM D-570 - 0.59%

The epoxy shall be applied to a clean dry concrete surface free of dust, dirt, grease, laitance, curing compounds and other foreign matter by sandblasting, mechanical abrasion or hydro blasting. Air surface temperature during application and curing shall be 40 Degrees F or above. Mixing shall be accomplished using a low speed drill with

a jiffy mixer or paddle. Epoxy shall be mixed in a clean dry container free of foreign matter or debris. Mixing rates shall be as recommended by the manufacturer.

In manholes with limited fall from pipe invert in to pipe invert out the concrete invert may need to be ground to allow continuous positive fall through the manhole. Mix epoxy in accordance with the manufacturers instructions. Epoxy may be brush applied in thin coats to provide a slick surface through the concrete invert of the manhole. Epoxy seems to perform best if applied prior to approximately the first ten to twelve minutes of pot life. The cured surface of the epoxy coating shall be free of brush marks and shall have a cross section consistent with that of the PVC pipe.

- (5) Manhole Waterproofing: When waterproofing is required by the Project Specifications or shown on the Plans the exterior surface of base, riser sections and cone shall be coated with minimum 10 mil coal tar epoxy. Waterproofing may be field applied.
- (6) Corrosion Protection: All drop manholes, force main outlet manholes and lift station wet wells shall be coated on the interior surfaces of the riser and cone with a minimum 20 mil thickness. Epoxy is to be shop applied to concrete after concrete has cured 28 days or steam cured over a 24-hour period or as required to meet the 28-day strength requirements. The epoxy shall be applied to a clean dry concrete surface free of dust, dirt, grease and laitance, curing compounds and other foreign matter by sandblasting, mechanical abrasion or hydro blasting. Air surface temperature during application and curing shall be 40 Degrees F or above. Mixing shall be accomplished using a low speed drill with a jiffy mixer or paddle. Epoxy shall be mixed in a clean dry container free of foreign matter or debris. Mixing rates shall be as recommended by the manufacturer.

Epoxy shall be applied in two coats to provide a minimum 20-mil thickness. Epoxy performs best if applied within the first ten to twelve minutes of pot life. 20-mil thickness shall be verified using a wet mil gauge. Estimated coverage area of one gallon of the product is 80 square feet at 20-mil thickness.

Apply coating in accordance with manufacturer's recommendations and allow drying and hardening prior to transporting precast sections to the project.

For application on existing manholes, epoxy may be used with prior City approval. City inspection of the manhole is required prior to application of the product to ensure proper surface preparation has been accomplished. The manufacturer's recommendations for application in confined space areas shall be followed.

- (7) Manhole Steps: Steps are required in all sanitary sewer manholes. Manhole steps shall be a manufactured copolymer polypropylene plastic step with ½" diameter, Grade 60 steel core. The steps shall be set in the wall of the manhole riser at the time the riser is manufactured. For precast manhole bases with integral riser sections, the steps shall be installed at a 45-degree angle from the inlet pipe. The spacing between steps shall

- (8) Pipe-to-Manhole Connector: Pipe-to-manhole connectors shall be manufactured with rubber conforming to ASTM C-923. All metal components shall be stainless steel.
- (9) Rings and Covers: Manhole rings and covers shall be cast iron dipped in asphaltic material to resist rusting. The standard City of Fruita manhole shall be Denver heavy pattern C.I. or approved, fully interchangeable substitute. The bearing surfaces between the ring and cover shall be machine finished or g round to assure non-rocking fit in any position and interchangeability. The cover shall have a beveled pick hole that has a width of ¾" at the top and 1" at the bottom. The length of the pick hole (along the circumference of the lid) shall be at least 1½". The word SEWER shall be cast in the cover as shown on *Sanitary Sewer Standard Details*. Inverted rings and covers will NOT be allowed unless approved by the City.
- (10) Watertight Manhole Covers: Where a watertight manhole is required, the ring and cover shall be equipped with a gasket or o-ring, the cover shall have no holes that could allow the intrusion of water into the manhole, the ring and cover shall be drilled and tapped at 120° spacing and 3 stainless steel bolts shall be furnished to secure the cover to the ring. Anti-seize compound will be applied to threads PRIOR to installation.

The standard ring and cover for watertight manholes shall be Castings MH-250-D- CI, bolted and gasketed, or approved equal.

- (11) Cast Iron Grade Rings: Under no circumstances will cast iron grade rings be permitted for new construction. Cast iron grade rings that fit in the top of existing manhole rings shall be the same diameter as the existing ring and shall have three setscrews for attachment to the existing ring.

- (G) **Concrete and Mortar.** All concrete used in construction of manholes, inlet boxes, vaults, concrete encasement, thrust blocks, etc., shall meet the requirements of the *Concrete Specifications*, and shall be made with modified Type II Portland cement.

Cement mortar used in construction or maintenance of manholes, inlets, vaults, etc., shall be a non-shrink grout conforming to ASTM C-109 and ASTM C-191

Rapid-Road Repair grout or approved equal is recommended for setting the ring and cover on top of the concrete grade rings.

All-Crete 5 Minute Set (Fostroc Inc, Georgetown KY) or approved equal is recommended for invert work.

### 3.4: Sanitary Sewer System Installation Specifications

- (A) **Installation of Gravity Flow Pipelines.** Gravity flow pipelines covered by this specification include: sanitary sewers, storm drains, culverts and non-pressurized irrigation

lines. All sanitary sewer facilities shall be in compliance with design criteria of the Colorado Department of Public Health and Environment.

- (B) **Pipe Laying of Gravity Flow Pipelines.** The pipe shall be placed to the line and grade shown on the Construction Drawings. Manholes shall be limited to one-foot horizontal variance from the designed location, unless otherwise approved by the City. Variance of elevations shall be limited to that necessary to meet field conditions and stay within the design parameters for the pipe slopes, and pipe materials originally approved by the City. Any variations of pipe size, pipe materials or reduction of pipe slope below design minimums shall be approved by the City

The Contractor shall set the line and grade of each joint of pipe with a laser V unless otherwise approved by the Engineer. The Contractor's surveyor shall set offset hubs at intervals of 50', 100' and 200' from the laser's location. Whenever the pipe is found to be outside the specified limits, the misaligned sections shall be removed and replaced to the correct line and grade at the Contractor's expense.

Pipe shall be laid upgrade from the point of connection to the existing sewer or from a designated starting point. Pipe with bell and spigot joints shall be laid with the bell end upgrade.

The inside of the pipe and jointing surfaces shall be kept clean and free from mud, soil, gravel, groundwater, and other foreign material. When pipe placement is not in progress, the upgrade end of the pipe shall be kept closed with a tightly fitting cap or plug.

- (C) **Sewer Line Stub Outs.** Sewer line stub outs shall be no longer than 10 feet. The minimum length of a stub out shall be 18". Service connections to stub-outs are not allowed. Each stub out shall be connected to the manhole with a Kor-n-seal gasket, or approved equal, and plugged with a PVC cap that can be removed for future extension, yet still prevent ground water infiltration.
- (D) **Installation of Sewer Service Lines.** Sewer service pipe within the public way shall be laid at a minimum grade of one-fourth (1/4) inch per linear foot unless otherwise approved by the City. Flatter slopes between one-eighth (1/8) and one-fourth (1/4) inch per foot will be allowed only when there is not enough elevation difference to achieve one-fourth (1/4) inch per foot. Prior to backfilling, a City Inspector may inspect sewer service pipe and connections to the sewer main. The Design Engineer shall establish the as-built location and alignment of service lines and show these items on the as-built drawings..

The maximum deflection permissible at any one fitting or any combination of adjacent fittings shall not exceed 90 degrees. 90-degree fittings shall be the long radius type. Install cleanouts every 100 feet or at each change of direction.

- (E) **Small Diameter Taps.** Four-inch service lines shall be joined to the new sewer mains with a full-body wye fitting connected above the spring line of the sewer pipe. For new main line installations the angled leg of the wye fitting shall be installed at an angle ranging between 45-60 degrees measured from the horizontal plane. This method of installation will result in the service pipe flow-line being one inch (1") minimum above the inside crown of the main pipeline barrel. Refer to the drawing on the City of Fruita *Sanitary*

(F) **Large Diameter Taps.** Six-inch or larger service taps shall be accomplished using a manhole, unless specifically authorized in writing by the City. On 8" or smaller main lines in which projected flows will be less than 1/3 full, the 6" service line shall enter the manhole approximately 0.2' higher than the invert of the existing pipe.

(G) **All taps.** Refer to Section 3.3(A). Verify that the supplied tee is intended for the diameter and type of the existing pipe. At no point shall the tee protrude more than 1/2 inch into the existing pipe.

For the installation of sewer service lines to properties that will not be immediately connecting or reconnecting to the sewer system, the service lines shall be stubbed out to the house side of the multi-purpose easement, utility easement or right-of-way line where no easement exists. The end of the pipe shall be plugged and marked with either a 2" x 4" board or steel fence post buried vertically above the end of the pipe and extending 3 feet above the ground surface with the exposed portion painted green. The City Of Fruita also highly recommends "stamping" the concrete curb with an "S" to indicate the service line location. The ends of the service lines shall be capped with watertight plugs braced to withstand test pressures. The horizontal location of each service tap shall be measured and shown on the As-Built drawings PRIOR to backfilling. The Contractor shall mark the end of the service with a post, as required above, with a reference mark and depth to the service pipe to be shot (for elevation) and documented at a later date. Tap locations shall be referenced using the stationing shown on the plans or referenced to property corners unless otherwise approved by the Engineer.

All service lines shall have a clean-out installed in accordance with the Uniform Plumbing Code. When the clean-outs are within the right of way, the clean-outs shall be enclosed in a 24" diameter concrete barrel with a standard ring and cover suitable for traffic loads as shown on the City of Fruita *Sanitary Sewer System Details* and section 3.9J.

Sub-drains, French drains or storm drains shall not be connected to sanitary sewers.

(H) **Construction of Manholes.** The foundation for each manhole base shall be prepared by replacing unsuitable in-place material with subgrade stabilization material in accordance with subsection 3.6(I) and placing granular bedding material in accordance with the City of Fruita *Sanitary Sewer Standard Details*.

The manhole base shall be precast or cast-in-place. The lines and grades of the pipe inverts shall be staked, as shown on the *Construction Drawings*. The inverts of sanitary sewer manholes shall be formed and smoothly finished to match the shape and elevation of all pipes connected to the manhole. Where the sewer line is designed with a continuous grade and horizontal alignment through the manhole, the line may be installed through the manhole, the top half of the pipe cut out for the full length of the manhole base formed around the bottom half of the pipe. A precast base with a precast invert may be used where there is at least 0.2 ft. of elevation difference across the manhole.

Sanitary sewer manholes inverts constructed with less than 0.2 ft. of elevation drop from pipe invert in to pipe invert out, and not constructed with the sewer pipe laid through the manhole as described above, shall be coated with an epoxy gel material as specified in subsection 3.3(F). The concrete invert shall be formed or removed to a depth to allow room to apply the epoxy coating to match to pipe invert and maintain positive fall through the manhole. The cured surface of the epoxy coating shall be smooth, free of trowel marks and shall have a cross section consistent with that of the PVC pipe.

All drop manholes, force main outlet manholes and lift station wet wells shall be coated on the interior surfaces in accordance with subsection 3.3(F).

Waterstops shall be installed on all pipes going into or out of a cast-in-place base. Waterstops shall be placed on both the uphill and downhill sides of the manhole on pipes laid continuously through a manhole. For precast bases the pipes shall be connected to the base with flexible rubber boots with stainless steel straps.

If cast-in-place bases are used, the first pre-cast manhole ring section shall be placed on the concrete base structure before the base has taken initial set, or the section shall be grouted into a suitable groove formed in the top of the manhole base. The first section shall be adjusted to the proper grade and alignment so that it is uniformly supported by the base concrete and not bearing on any of the pipes. The manhole steps shall be located approximately one-foot left or right of the main inflow pipe so that the final installation of the cone will result in the centerline of the access hole being at a 45 degree angle from the centerline of the main line. Refer to the City of Fruita *Sanitary Sewer Standard Detail Sheet* and sections 3.8D, 3.8E, and 3.8F.

The remaining pre-cast sections shall be placed and aligned to provide vertical sides and alignment of the ladder rungs. Plumbness shall be checked as each barrel section is added. A preformed bitumastic joint sealant (BMS) or other approved sealer shall be placed between pre-cast sections so that the completed manhole is rigid and watertight.

The manhole ring and cover shall be adjusted to the final pitch and grade with epoxy topcoat and non-shrink grout and precast concrete grade rings. Refer to the City of Fruita *Sanitary Sewer Standard Detail Sheet* and sections 3.9D, 3.9E and 3.9F. The total height of grade rings shall not be more than twelve (12) inches or more than three rings. The space between the grade rings shall be sealed with a bitumastic sealant no greater than 3/8 inches thickness and the cast iron ring set in a bed of mortar at the finished grade elevation. Cast iron grade rings shall not be used to adjust the elevation of the manhole lid, except when a street is being overlaid. Inverted rings and covers will not be permitted without the approval of the City.

Where the manhole is located in an unpaved street, alley or other area where grade has not been established, 6 to 12 inches of grade rings shall be placed between the top of cone and bottom of the ring (to allow future adjustment of the ring to grade).

Where a manhole is in a cultivated area, landscaped area, flood plain or other area subject to inundation, at the discretion of the City, a watertight manhole cover shall be used.

All newly constructed manholes shall be cleaned of any accumulation of silt, debris or foreign matter of any kind, and shall be free from such accumulations at the time of final

inspection. All preformed bitumastic joint sealant shall be trimmed flush with manhole wall.

**3.5: Accessory Dwelling Units.** An accessory dwelling unit or units detached from the parent dwelling shall have a separate sewer tap and service line provided.

**3.6: Excavation, Backfill Removals and Restoration Specifications**

- (A) **Description.** This section covers surface removals, excavation, backfilling, compaction, disposal of surplus material, restoration of disturbed surfaces, and all other work required for the safe and proper construction of sanitary sewers.
- (B) **Survey Line and Grade.** All construction surveying and staking shall be performed by or under supervision of a professional engineer or land surveyor registered in the State of Colorado. The Contractor shall use a laser instrument to maintain and control the line and grade of all gravity flow pipelines including sanitary sewers, storm drains and irrigation lines. Check points shall be set at 50 feet, 100 feet and 200 feet from the beginning of each reach of pipe to assure that the laser is on the correct line and grade.
- (C) **Right-of-Way Permits.** Right-of-way Permits must be obtained from the Public Works Department prior to commencing the work.
- (D) **Removal of Structures and Obstructions.** The removal of structures and obstructions shall be in accordance with subsection 4.3 of the Street System Standards. The Contractor shall remove surface materials and obstructions only to the widths necessary for excavation of the trench. All trees, shrubbery, fences, plantings and structures not designated for removal shall be protected or, if moved, restored to their original condition after construction is complete.

Removal of concrete curbs, gutters, sidewalks, driveways and asphalt pavement shall be along existing joints or neatly cut lines. All vegetation, concrete, asphalt and other refuse removed from the construction limits shall be separated from suitable topsoil and backfill material, and hauled to a disposal site secured by the Contractor. Where the trench is in an unpaved area, clean topsoil suitable for final grading shall be stripped, stockpiled separately in approved locations, and restored to the original thickness after the trench is backfilled.

- (E) **Trench Protection.** All trenches greater than 4 feet in depth shall have trench shields, sheeted or otherwise supported to provide safe working conditions and protection of the work, workers and adjacent property. Trench shields and other support methods shall conform to the recommendations in the Occupational Safety and Health Standards for Construction (OSHA). Unless otherwise approved, all trench support materials shall be removed in a manner that will prevent caving of the sides and movement or other damage to the pipe.
- (F) **Trenches with Sloping Sides.** Where working conditions and right-of-way width permit, trenches in unimproved areas may be excavated with sloping sides in accordance with OSHA requirements. All soils shall be assumed to be OSHA Type C Soil, unless otherwise



classified by a qualified soils technician. Trenching and other excavations shall not extend beyond existing easements, right-of-way or limits shown on the *Construction Drawings* unless otherwise approved by the property owner and the City Engineer.

In streets, alleys or narrow easements, trenches shall be excavated with vertical sides and properly supported. Where trenches with sloping sides are permitted, the slopes shall not extend below a point 12 inches above the top pipe.

- (G) **Open Excavation Limits.** The length of open trench shall be kept to a minimum and shall not exceed the length necessary to accommodate pipe laying and backfilling operations that will occur in a normal workday, unless otherwise approved by the City. In other words, trenches may be cut and left open overnight, with the expectation that pipe laying and backfill will occur the following day. In no case shall an open trench exceed the spacing between manholes. The Contractor shall be responsible for covering or barricading unattended trenches and excavations as necessary for protection of the public and the work.

(1) **Trenches within the Public Right of Way.** All trenches and excavations shall be backfilled at the end of each workday, unless otherwise shown on the plans or approved in writing by the City Public Works Department. The end of the trench may be left open overnight if the entire perimeter of the excavation is fenced, lighted and barricaded with construction equipment or other devices approved by the City Public Works Department. Any excavation within the right of way requires a Right of Way permit and traffic control plan approved by the City Public Works Department.

(2) **Trenches outside the Public Right of Way.** Pipeline installation shall follow trench excavation as soon as practical. A pipe installation plan will be presented to the City for approval prior to any excavation beginning.

- (H) **Unauthorized Excavation and Pavement Removal.** Unless authorized by the City, all removed pavement and excavations made beyond the lines and grades shown on the *Construction Drawings* or described in the *Contract Documents* shall be replaced at the Contractor's expense.
- (I) **Unstable Trench Bottom.** Where the excavation is found to consist of muck, organic matter or any other material that is determined by the City, to be unsuitable for supporting and maintaining the line and grade of the pipe, the trench shall be excavated to an additional depth as agreed upon by the Contractor and Construction Inspector/Engineer, and replaced with a *Type B* granular stabilization material as shown in the City of Fruita *General Construction Notes* and section 1.4D. Should the Contractor and Inspector/Engineer fail to reach an agreement as to the depth and/or method of trench foundation stabilization; the developer shall secure the services of a geotechnical engineer to assist in determination of an appropriate method for stabilization.
- (J) **Bedding and Shaping Trench Bottom.** Unless otherwise directed, all trenches shall be excavated to at least six (6) inches below the pipe grade and backfilled to six (6) inches above the pipe with a *Type A* granular bedding material as shown in the City of Fruita

*General Construction Notes.* The bedding material shall be hand shaped and graded until the trench bottom is uniform and free from rocks, bumps and depressions. A coupling or bell hole shall be dug at each pipe joint with sufficient length, width and depth to permit assembly of the joint and provide a minimum clearance of two (2) inches between the coupling and the trench bottom. After the pipe is joined, pipe-bedding material shall be placed and tamped under each pipe joint until all voids are filled. Care shall be taken not to displace the pipe from its line and grade.

- (K) **Cutoff Walls.** A minimum of one cutoff wall is to be installed 10-20 feet upstream of each manhole or box to prevent groundwater flow through the pipe bedding material. Cutoff walls shall be five (5) feet long and consist of native material or imported material that has a permeability rate the same or less than that of the native material. Cutoff walls shall replace the *Type A* granular bedding material. Cutoff walls on pressurized lines shall be installed at intervals not exceeding 200 feet.
- (L) **Rock Excavation.** Rock excavation shall consist of the removal of boulders or concrete measuring one-half (1/2) cubic yard or more, hard shale, sandstone or other bed rock which, in the opinion of the Engineer, requires for its removal the continuous use of pneumatic tools or drilling and blasting. Rock excavation shall be in accordance with Section 203 of the *CDOT Standard Specifications for Road and Bridge Construction*.
- (M) **Stockpiling Excavated Material.** Excavated material shall be piled in accordance with OSHA guidelines in locations that will not endanger the Work, create traffic hazards or obstruct sidewalks and driveways. Fire hydrants, valve boxes, manholes and other utility access points shall be left unobstructed. Gutters and other watercourses shall not be obstructed unless other satisfactory provisions are made for runoff and street drainage.

All surplus material and excavated material unsuitable for backfilling shall be removed from the site and disposed of in areas secured by the Contractor.

- (N) **Dewatering Trenches.** Trenches shall be kept free of water during pipe laying operations by draining, pumping or other approved methods. The water level shall be maintained at least six (6) inches below the trench bottom throughout the placement of bedding, pipe laying, joining and backfilling operations. The dewatering shall be carried out so that it does not destroy or weaken the strength of the soil under or along the side of the trench. The City shall approve the method of disposal of trench water. Watertight plugs shall be installed in the ends of all water and sewer lines when the trench is not being dewatered.

Surface water from any source shall be prevented from entering the trench excavation.

- (O) **Backfilling Pipe and Structures.** Unless otherwise specified or approved by the City, all backfill material shall be placed with moisture-density control in accordance with the typical trench detail shown on the City of Fruita *General Construction Notes* and section 1.4D. All backfill soils shall be adjusted within +/- 2% of the optimum moisture.

A minimum of 24 inches of compacted backfill shall be placed over the top of all polyvinyl chloride (PVC) and polyethylene (PE) pipes before vehicles or heavy equipment are allowed to pass over the pipe. Less cover may be allowed only where *flow-fill* or other approved material is used for the pipe haunching and backfill material. Flow-fill shall meet the requirements of section 5.10 of the Concrete Standards, or the standards shown on the City of Fruita *General Construction Notes* and section 5.1M unless approved by the City Engineer.

During initial backfilling, the Contractor shall take all necessary precautions to prevent movement or distortion of the pipe or structure being backfilled. Pipe haunching material shall be placed and compacted in even lifts on both sides of the conduit to six (6) inches above the top of the pipe. Above the bedding and haunching material, earth backfill material shall be placed full width in uniform layers not more than twelve (12) inches thick. Each layer shall be compacted to the required density with approved mechanical or hand tamping equipment. Hydro-hammers or other heavy compaction equipment shall not be used unless approved by the City. No hydro-hammer shall be used for compaction with less than 48 inches of cover over the pipe.

It shall be the Contractor's responsibility to make necessary excavations and to provide safe access into the excavations in accordance with OSHA Standards in order to accommodate compaction tests at all locations designated by the authorized Technician.

- (1) **Backfill Testing Requirements:** All backfill shall be frequently tested to insure that the required density is being attained. For every 400 lineal feet of trench and each branch or section of trench less than 400 feet in length, at least one compaction test shall be performed for each two-foot vertical depth of backfill material placed. The first test shall be taken approximately two feet above the top of pipe and the last test shall be at the pavement subgrade or 6 inches below the ground surface in unpaved areas. Compaction tests shall be taken at random locations along the trench and wherever poor compaction is suspected. If any portion of the backfill placed fails to meet the minimum density specified, the material will be recompacted both upstream and downstream of the failed test location a distance equal to  $\frac{1}{2}$  the distance from where the next test was taken or 165 feet, whichever is least. An alternative procedure would be to more clearly define the limits of the failed area by additional tests. If necessary, the material in the designated area shall be removed and replaced with material that can be properly compacted.

Failed compaction tests shall be immediately reported to the Inspector and the Contractor. A summary report of all compaction test results, including retests of failed tests and a test location map or other approved location format shall be submitted to the Project Engineer and to the Contractor. Compaction test results are required as a basis of acceptance of facilities by the City in accordance with subsection 1.3.B.

- (2) **Backfilling Concrete Structures:** Concrete structures shall not be backfilled until the concrete and mortar therein has attained a minimum compressive strength of 2000 psi and can sufficiently support the loads imposed by the backfill. Earth backfill shall be

placed simultaneously on all sides of the structure in layers not to exceed 8” inches thick. Each layer shall be compacted to not less than ninety-five percent (95%) of the maximum dry density determined in accordance with AASHTO T-99 or T-180.

<b>TABLE 3.1 REQUIRED QUALITY ASSURANCE (QA) AND QUALITY CONTROL (QC) TESTING City of Fruita, Colorado</b>			
<b>TEST REQUIRED</b>	<b>TEST PROCEDURE</b>	<b>REQUIRED OR ALLOWED RANGE</b>	<b>MINIMUM TEST FREQUENCY</b>
Compaction of bedding and haunching materials (except crushed rock)	AASHTO T 99 and T 238	90% minimum at +/- 2% of optimum moisture. (see notes)	1 per 400 L.F. of trench (and each branch or section of trench less than 400 feet in length) for each two foot vertical depth of backfill material.
Trench Compaction to subgrade  1. Within right of way.  2. In unimproved areas outside of right of way or within landscaped areas.	AASHTO T 99 and T 238	95% compaction minimum at +/- 2% of optimum moisture. (see notes)  85% compaction minimum	
Compaction of aggregate base course material*	AASHTO T 180 and T 238	95% compaction minimum at +/- 2% of optimum moisture*. (see notes)	1 per 300 S.Y.
Compaction of subgrade within 24" of all structures ( <b>manholes, catch basins, valves, vaults, etc.</b> )	AASHTO T 99 and T 238	95% compaction minimum at +/- 2% of optimum moisture. (see notes)	1 per each two-foot vertical depth of backfill material or per 100 L.F. of structure perimeter
Flowfill	Mix design	50 psi to 200 psi	Submit mix design prior to use.
Compaction of rock, pit run, or other material that cannot be tested by normal procedures.	Field Inspection / Method Specification	Minimum 3 passes with wheeled compactor (smooth drum, vibratory, sheepsfoot or 4 passes with plate compactor.	Field / full time inspection only. Trenches at discretion of Engineering.
<p><b>Notes:</b></p> <p><b>If minimum moisture density requirements are <u>not</u> met by these tests, the contractor shall recompact the trench as needed to achieve the specified compaction. Such recompaction shall extend both upstream and downstream of the failed test section a distance equal to 1/2 the distance from where the last test was taken or 165 ft., whichever is least. An alternative procedure would be to more clearly define the limits of the failed area by additional tests.</b></p> <p><b>For unpaved travel surfaces, (gravel, recycled asphalt, etc.) all material within 12” of finish road surface shall be compacted to 95% minimum of AASHTO T180.</b></p> <p><b>*Regarding compaction of aggregate base course material – Moisture requirements may be adjusted at the discretion of the City of Fruita.</b></p> <p><b>A minimum of one test will be required for any portion of material less than that shown in the “Minimum Test Frequency” column, unless otherwise approved by the City inspector.</b></p>			

- (P) **Granular Stabilization, Bedding and Haunching Materials.** Granular materials required for stabilization of poor subgrade soils, bedding of pipe and structures, and haunching around pipe shall meet the following gradation requirements:

Sieve Size	Percent, passing by weight		
	Pipe bedding & haunching Type A (crushed rock)	Granular Stabilization Type B (screened or crushed rock)	Imported backfill material (use only where specified or directed by the City)
4 inch	---	---	100
2 inch	---	100	---
1 inch	100	---	---
# 4		15 max.	---
No. 200	20 max.		3 – 20 max. Plastic index (PI) shall not be more than 7

Crushed rock shall be the product of crushing rock and gravel. The portion of the material larger than will pass a 3/8-inch sieve shall contain at least 50 percent of particles having two or more fractured faces. Not over 5 percent shall be pieces that show no fractured faces.

- (Q) **Earth Backfill Material.** Earth backfill material shall consist of approved materials developed from project excavations or imported from another source. To be suitable for backfill, earth material shall be free from muck, frozen lumps, ashes, trash, vegetation and other debris. All excavated materials that, in the opinion of the Engineer, are unsuitable for use in the backfill shall be removed from the site and disposed of by the Contractor at his expense. The maximum size of rock or clod allowed within 6" of any plastic pipe shall be one (1) inch. The maximum size of rock or clod allowed within 6" of a rigid pipe or structure shall be three (3) inches.

- (1) *Proof Rolling:* Prior to paving and after compaction of the road base the Contractor shall roll the compacted backfill material to test for deflection. The Contractor shall furnish a rubber-tired, self-propelled vehicle for proof rolling. Acceptable proof rolling equipment includes a loaded water truck or loaded dump truck. If while proof rolling, any visible deflection or rutting is observed, the City may require the base material to be removed and backfilled with angular aggregate material or a structural membrane.

- (R) **Restoration of Grounds.** The cleanup and restoration of grounds shall be a continuous process from the beginning of construction to final completion of the Work. The Contractor shall keep the work site free from accumulation of debris and waste material caused by his operation. In the case of point-location work to be performed later in the construction process, such as water line tie-ins, the restoration (but not the clean up) of the

area adjacent to the point-location may be delayed until the point-location work is performed.

- (1) After the pipeline is backfilled, the area shall be cleaned and restored to the original grade and condition. The cleaning and restoration shall be kept up to no greater than 500 feet behind the backfill operations.
- (2) All fences, utilities, culverts, ditches, structures, grassed areas and plantings shall be replaced and restored to a condition equal to or better than that at the beginning of construction.
- (3) The restoration of asphalt and concrete surfaces and structures may be performed at the completion of a segment of the project, unless otherwise specified. A segment is defined as one contiguous length of pipe installed.

- (S) **Restoration of Concrete and Pavement Surfaces.** The Contractor shall replace all concrete and pavement surfaces removed or damaged by his operation. All paving, aggregate base course and concrete replacement work shall be in accordance with the *Street System Standards*. Paving and/or patching for an entire project may be performed as a single operation unless otherwise specified.

Prior to paving or patching all edges that have been broken, raveled or otherwise damaged shall be recut to a neat line. Refer to subsection 4.3 of the *Street System Standards*.

### 3.7: Sanitary Sewer Pipeline Testing

- (A) **General.** All sanitary sewers shall be tested before final acceptance. The contractor shall notify the City of any testing schedules. The Contractor under direct control and observation of the Engineer of Record or an approved independent laboratory, and a representative of the City shall perform all testing. The Contractor shall furnish all labor, equipment, tools, water and other incidental items required to conduct the tests
- (B) **Re-testing.** If a pipeline fails to meet the test requirements, the leak or other deficiency shall be located and repaired at the Contractor's expense. After the repairs or corrections have been made, the pipeline shall be retested. Repairs and retesting shall continue until the test requirements have been met.
- (C) **Leakage Tests.** A leakage test shall be performed on all newly constructed sanitary sewers. The City will determine which test(s) will be made and the Contractor shall furnish all labor, tools and equipment necessary to conduct the test. The allowable types of tests are exfiltration of water, exfiltration of air, infiltration of water, and infiltration of air.
- (D) **Exfiltration of Water Test.** The length of pipeline to be tested shall be limited so that the pressure on the lower end of the test section does not exceed 10 feet of water column. The test section shall be sealed off from the remaining pipeline with watertight plugs inserted in the pipes. The Contractor shall fill the pipe to the test level with potable water at least 24

hours prior to conducting the test. The test level shall be at least 2 feet above the top of the pipe, in the upper manhole, or 2 feet above the ground water table, whichever is higher.

Throughout the test period of at least 1 hour, the water level shall be maintained at the test level and all water added shall be accurately measured. The exfiltration rate shall not exceed 0.15 gallon per inch of inside pipe diameter per hour per 100 feet of pipe length.

(E) **Exfiltration of Air Test.** The Contractor may conduct a preliminary air test prior to placement of the permanent surface. Preliminary tests will be considered to be for the Contractor’s convenience and need not be performed in the presence of the City Inspector. Air testing shall be in accordance with ASTM C-828 or ASTM F1417-92. The ends of the test section shall be sealed at the upper and lower manholes with pneumatic plugs. One of the plugs provided shall have two taps. One tap will be used for introducing air into the pipeline through suitable valves and fittings so that the input air may be regulated. The second tap shall be fitted with valves and fittings to accept a pressure gauge to monitor the internal pressure of the sewer pipe.

(1) The pressure gauge shall meet the following minimum specifications:

- Size .....4-½ inch diameter
- Pressure range .....0 - 15 psi
- Figure intervals .....1-psi increments
- Smallest intervals .....0.1 psi
- Pressure tube .....Bourdon tube or diaphragm

(2) Connect the pressure gauge and air control equipment to the proper fittings and slowly apply air pressure. Pressurize the pipe line to 4.0 psig and throttle the air supply to maintain the pressure between 4.0 and 3.5 psig for at least 2 minutes in order to allow equilibrium between air temperature and pipe walls. During this time check all plugs for leakage. If any plugs are found to leak, bleed off the air, tighten the plugs and re-pressurize the pipeline. After the temperature has stabilized, allow the pressure to decrease to 3.5 psig. At 3.5 psig begin timing to determine the time required for pressure to drop to 2.5 psig. The time, in seconds, for the air pressure to decrease from 3.5 psig to 2.5 psig shall be greater than the minimum test time shown in the following table.

Pipe Size (inches)	Time (min/100 ft)	Pipe Size (inches)	Time (min/100 ft)
4	0.3	24	3.6
6	0.7	27	4.2
8	1.2	30	4.8
10	1.5	33	5.4
12	1.8	36	6
15	2.1	39	6.6
18	2.4	42	7.3
21	3.0		

In areas where the ground water level is above the pipe, the hydrostatic pressure of the ground water above the pipeline shall be determined and added to all test pressures (1 ft. of water = 0.43 psi). Air testing shall not be done if the groundwater level is greater than 10 feet above the sewer line.

- (F) **Infiltration of Water Test.** If the sewer line is in an area where the water table is 2 feet or more above the pipeline, an infiltration test may be used. Infiltration tests shall be completed prior to placing new sewer lines in service. Throughout the test period of at least 1 hour, the rate of infiltration of ground water shall be accurately measured using weirs inserted in the pipeline downstream of manholes where flow is present. The infiltration rate shall not exceed 0.15 gallon per inch of inside pipe diameter per hour per 100 feet of pipe length.
- (G) **Infiltration of Air Test.** At the discretion of the City manholes will be tested using the negative air pressure test (vacuum) in accordance with ASTM C 1244-93, or latest edition, for water tightness, and manhole will be visually inspected after backfilling. Contractor may backfill before testing with the understanding that any repairs will be made from the exterior of the manhole.
- (1) Manholes shall be vacuum tested and shall have 10 inches of mercury applied to the manhole and the time measured for the vacuum to drop from 10 inches to 9 inches of mercury. The City Engineer prior to its use shall approve vacuum equipment.
  - (2) Test times for structures other than manholes will be based on the times for manholes of the nearest equivalent volume or as directed by the Engineer.
  - (3) Written verification must be furnished that the following steps are followed:
    - (a) The test method is only to be applied to precast concrete manholes.
    - (b) Stub outs, manhole boots and pipe plugs shall be secured to prevent movement while the vacuum is drawn.
    - (c) If a manhole fails during the test, necessary repairs shall be made and the vacuum test repeated until the manhole passes the test.
  - (4) Vacuum Test (ASTM C1244) for Concrete Sewer Manholes. Minimum allowable test times shall be as follows:

MINIMUM TEST TIMES FOR VARIOUS MANHOLE DIAMETERS

Depth (Ft)	Diameter (In)					
	36	48	54	60	66	72
	Time (Sec)					
8 or less	14	20	23	26	29	33
10	18	25	29	33	36	41
12	21	30	35	39	43	49
14	25	35	41	46	51	57
16	29	40	46	52	58	65
18	32	45	52	59	65	73
20	35	50	58	65	72	81



NOTES:

The test head shall be placed at the top of the manhole in accordance with the manufacturer's recommendations.

A vacuum of 10 inches of mercury shall be drawn on the manhole, the valve on the vacuum line of the test head closed, and the vacuum pump shut off. The time shall be measured for the vacuum to drop to 9 inches of mercury.

The manhole shall pass if the time for the vacuum reading to drop from 10 inches to 9 inches of mercury meets or exceeds the values indicated above.

If the manhole fails the initial test, necessary repairs shall be made by an approved method. The manhole shall then be retested until a satisfactory test is obtained.

- (H) **Alignment Testing.** All sanitary sewer lines shall be observed for correct alignment by laser testing. If the line does not pass the laser test or if something other than crushed rock was used for pipe bedding, deflection testing shall be performed on flexible pipe or appropriate repairs shall be made on rigid pipe.
- (I) **(1) Closed Circuit Television (CCTV).** The contractor shall notify the City's Engineering Inspector after sewer main installations to schedule the required CCTV testing. The Inspector will arrange CCTV inspection with the Public Works Department. A minimum 48 hour notice is required. CCTV inspection is performed only after sewer main installation, required air testing, and cleaning and vacuuming. The City conducts video inspections at no expense to the Contractor on new sewer mains installed in street right-of-ways. Significant deficiencies observed during video inspection will require correction and CCTV reinspection by the City at the Contractor's expense. The Contractor shall, at his expense, remedy all identified deficiencies to the satisfaction of the Public Works Department. The Contractor may, at his expense, camera sections of the line but Contractor performed CCTV work will not be accepted for compliance purposes. All bored or micro-tunneled sewer lines 6 inches and greater shall be CCTV inspected by the City.
- (J) **Process for Requesting a Sewer Line Camera Test:**
1. All camera tests are arranged through the Engineering Department Inspector, who submits a work order request to Public Works. Camera tests are scheduled in the order received. A status list of scheduled camera tests, showing expected completion schedule for the field work, can be obtained from Public Works or the Engineering Inspector.
  2. The entire filing must be ready at one time for the camera test, the sewer lines must be jet cleaned and all manholes and pipe connections at the manholes properly grouted.
  3. Camera tests may be done before road base is placed, however only if the subgrade surface is firm, dry, smooth, and accessible. Road subgrade along the entire sewer line alignment shall be completed to final grade to the limits of the

future asphalt section, all extra earth material shall be removed and all holes shall be filled and compacted.

4. The downstream air plugs will remain in place during flushing, cleaning, and camera work. The air plugs cannot be removed without City approval.
5. Allow at least four working days for Public Works to complete the field work order and for Engineering to install GIS coordinates. All work schedules are dependent upon the proper operation of the CCTV equipment
6. Contractors / Developers are not permitted in the camera truck. The camera operator only gathers data. After the camera test, the Director and Supervisor of Public Works will review the test information for acceptance.
7. Allow Public Works two days to produce the report after completion of the field work. They will forward the report results to the Engineering Inspector, who will inform the developer/contractor of the results. The contractor may request a copy from the Engineering Department
8. If a line segment fails only due to the presence of unacceptable amounts of debris, the contractor must have the line jetted and vacuumed before final sewer approval/acceptance will be given. A receipt will be required for verification of the jetting and vacuuming work. A re-inspection may be scheduled at the discretion of Public Works.
9. When line segments fail the test due to sags, bad joints, low taps, excessive debris, etc., the camera truck will be scheduled for return inspection only after all repairs are complete. The same CCTV inspection procedures will be used for all re-inspections. **Retests do not jump to the head of the list.** The retested segments will be charged to the contractor. Repair of low taps may be verified in open trench by the City Inspector.

(K) **Before Compliance Air Testing:**

1. At a minimum, the dry utilities trenches must be completed and compacted road base placed before the compliance air tests are scheduled. Previous air tests are at the contractor's discretion.

(L) **Issuance of Preliminary Sewer Line Acceptance:**

Preliminary Sewer Line acceptance is only applicable before street paving is applied. Sewer System Preliminary Approval is provided only after all repairs, cleaning and re-camera work (if needed) is completed, a passing air test is conducted, **preliminary as-built information is provided showing invert elevations and pipe slopes**, and all charges for re-inspection have been paid to the City. Planning Clearances for construction of structures will not be issued without a Sewer System Approval.

### **3.8: Final Inspection and Acceptance**

- (A) **General.** Final approval/acceptance of the sewer system occurs only after final paving and setting of manhole rims and covers. The City reserves the right to re-camera, require re-cleaning or otherwise withhold final approval if there is indication that damage or debris affecting the sewers has occurred subsequent to the Sewer System Clearance.
- (B) **Inspection Results Submittal and Documentation.** Any tests (such as pipeline pressure test, leakage tests, disinfection tests, compaction tests, etc.), required to be performed by the Contractor and certified by the Engineer of Record or an approved independent laboratory, shall be submitted to the Fruita Engineering Department before any approvals are provided.
- (C) **As-built Drawings.** Developer/contractor shall submit final As-built drawings in hard copy and as an electronic AutoCAD file in accordance with the City of Fruita submittal standards in Chapter 1.
- (D) Certificates of Occupancy for occupied structures will not be issued until all requirements of this section are satisfied.

### **3.9: Sanitary Sewer System Details**

- A. Sanitary Sewer Notes**
- B. Sanitary Sewer Notes**
- C. Water/Sewer Crossing Concrete Encasement**
- D. Standard Manhole Cast-in-Place Base**
- E. Drop Manhole Precast Base**
- F. Shallow Manhole Cast-in-Place Base**
- G. Connection to Existing Manhole**
- H. Typical “Y” Service Connection**
- I. Manhole Ring & Cover**
- J. Standard Sewer Cleanout**
- K. Type “A” Commercial Sand & Oil Interceptor**
- L. Type “B” Industrial Sand & Silt Interceptor**
- M. Commercial Grease Interceptor**

**N. – P. Force Main Cleanouts and Flush Drains**

**Q. Flow Metering and Sampling Station**

SANITARY SEWER NOTES:

1. ALL SEWERLINE CONSTRUCTION SHALL CONFORM TO THE CITY OF FRUITA'S STANDARDS AND SPECIFICATIONS.
2. ALL SANITARY SEWER PIPE SHALL BE PVC SDR-35 UNLESS OTHERWISE SPECIFIED. ALL PIPE JOINTS SHALL BE 13' JOINTS UNLESS OTHERWISE APPROVED BY THE CITY ENGINEER.
3. ALL SEWER MAINS SHALL BE LAID TO GRADE UTILIZING A PIPE LASER.
4. ALL SERVICES LINE CONNECTIONS TO THE NEW MAIN SHALL BE ACCOMPLISHED WITH FULL-BODY WYES OR TEES. TAPPING SADDLES WILL NOT BE ALLOWED.
5. ALL TRENCHES SHALL BE COMPACTED PER TRENCH DETAIL (SEE STANDARD TRENCH DETAIL) CONTRACTOR SHALL BE REQUIRED TO PERFORM ALL NECESSARY COMPACTION TESTS THROUGH A CERTIFIED SOILS LAB.
6. A MINIMUM 10' SEPARATION SHALL BE MAINTAINED AT ALL TIMES BETWEEN WATER LINES AND SEWER LINES (EXCEPT AT SPECIFIED CROSSINGS).
7. SEWER SERVICE STUB-OUTS SHALL EXTEND 14' BEYOND THE PROPERTY LINE OR THROUGH FRONT LOT EASEMENTS, WHICHEVER IS GREATER, AND SHALL BE GLUE-CAPPED AND MARKED WITH A 2"x4" POST PAINTED GREEN AND BURIED SO THAT 3' REMAINS ABOVE GRADE. ASBUILT SURVEYING FOR VERTICAL GRADE OF STUB-OUT REQUIRED PRIOR TO BACKFILL.
8. NO SERVICE LINES SHALL BE CONNECTED DIRECTLY INTO MANHOLES UNLESS OTHERWISE APPROVED BY THE CITY ENGINEER.
9. THE CONTRACTOR IS RESPONSIBLE FOR ALL REQUIRED SEWER LINE TESTING TO BE COMPLETED IN THE PRESENCE OF THE CITY ENGINEER OR THEIR REPRESENTATIVE. FINAL ACCEPTANCE IS TO BE ACCOMPLISHED ONLY AFTER ALL OTHER INFRASTRUCTURE HAS BEEN INSTALLED. THIS INCLUDES WATERLINES, GAS LINES, ELECTRIC LINES, ETC. VIDEO INSPECTION AND AIR TESTING WILL BE PERFORMED AFTER ALL COMPACTION OF STREET SUBGRADE AND PRIOR TO STREET PAVING. FINAL MANHOLE INSPECTION WILL ALSO BE ACCOMPLISHED AFTER PAVING IS COMPLETED TO INSURE THAT THE LINE IS CLEAN. THESE TESTS WILL BE THE BASIS FOR ISSUING INITIAL ACCEPTANCE OF THE SEWER LINE EXTENSION.
10. MANHOLES SHALL BE CONSTRUCTED AS SHOWN ON THE CITY OF FRUITA SANITARY SEWER STANDARD DETAIL SHEET.
11. WATER STOPGASKETS AND CLAMP ASSEMBLIES ARE TO BE FURNISHED AND INSTALLED AT ALL CONNECTIONS TO MANHOLES.
12. WHEN INSTALLING MANHOLES OVER EXISTING SEWER LINES, CONTRACTOR IS TO EXPOSE EXISTING SANITARY SEWER MAIN TO ALLOW THE ENGINEER TO FIELD VERIFY EXISTING PIPE INVERTS PRIOR TO CONSTRUCTION OF MANHOLES AND ADJUST THE INVERT ELEVATIONS IF REQUIRED. THE CONTRACTOR SHALL PLACE TYPE "A" BEDDING MATERIAL AND POUR THE BASE OF THE MANHOLE AND COMPLETE THE MANHOLE AS PER THE CITY OF FRUITA'S SANITARY SEWER STANDARD DETAILS. THE CONTRACTOR AT THAT TIME CAN NOTCH OUT OR CUT THE EXISTING PIPE OUT TO THE SPRING LINE OF THE PIPE. THE CONTRACTOR SHALL CONTROL ALL LIVE SEWAGE FLOW AND SHALL NOT ALLOW DEBRIS FROM THE CUTTING OTHER WORK TO ENTER THE EXISTING PIPELINE WHILE THE WORK IS BEING DONE. THE CONTRACTOR SHALL ADVISE THE CITY WHEN THE CONCRETE BASE WILL BE PLACED SO THAT A REPRESENTATIVE OF THE CITY MAY BE PRESENT.
13. PIPE-TO-MANHOLE CONNECTOR: PIPE TO MANHOLE CONNECTORS SHALL BE MANUFACTURED WITH RUBBER CONFORMING TO ASTM C-923. ALL METAL COMPONENTS SHALL BE STAINLESS STEEL.
14. STEEL PAVING RINGS ARE NOT ALLOWED FOR GRADE ADJUSTMENT UNLESS OTHERWISE APPROVED BY THE CITY ENGINEER. THE SPACE BETWEEN CONCRETE GRADE RINGS SHALL BE SEALED WITH A BITUMASTIC SEALANT NO GREATER THAN 3/8" THICK.
15. ALL RESIDENTIAL SANITARY SEWER SERVICES ARE TO BE 4"Ø PVC SDR-35 UNLESS OTHERWISE SPECIFIED.
16. A MINIMUM OF ONE CLAY CUT-OFF WALL IS TO BE INSTALLED UPSTREAM OF EACH MANHOLE TO PREVENT GROUNDWATER FLOW THROUGH THE PIPE BEDDING MATERIAL.
17. MANHOLE SPACING REQUIREMENTS:  

<u>PIPE Ø</u>	<u>MANHOLE SPACING</u>
15" OR SMALLER	400'
18" OR LARGER	500'
18. MAXIMUM CHANGE IN DIRECTION IN MANHOLES FOR LINES 18" AND LARGER SHALL BE 45°.
19. SEWER LINES SHALL BE STRAIGHT AND NOT CURVED BETWEEN MANHOLES, BOTH IN LINE AND GRADE.
20. THE MINIMUM COVER FOR SEWER MAIN IS TYPICALLY 4' (TOP OF PIPE TO FINISH GRADE) UNLESS SHOWN OTHERWISE ON THE DRAWINGS. WHERE COVER IS LESS THAN 2' FROM TOP OF SEWER PIPE TO BOTTOM OF ROADWAY BASE COURSE, FLOWABLE FILL CONCRETE SHALL BE USED AS BACKFILL.

CITY OF FRUITA ENGINEERING DEPARTMENT	SCALE HORIZONTAL: N/A VERTICAL: N/A	REVISION: 2009 STANDARDS REVISION REVISION: _____ REVISION: _____	DATE: 3/18/09 DATE: _____ DATE: _____	SANITARY SEWER NOTES	FILE: SHEET: 39A	DRAWN BY: CLD DATE DRAWN: 5/06 CHECKED BY: _____
--	---	---	---	----------------------	---------------------	--

SANITARY SEWER NOTES:

1. CONCRETE SHALL BE CITY OF GRAND JUNCTION SPECIFICATIONS, SECTION 601-STRUCTURAL CONCRETE CLASS B.
2. ALL CEMENT USED IN MORTAR, CONCRETE BASES, GRADE RINGS, RISER SECTIONS, CONES, AND FLAT TOPS, FOR SANITARY SEWER MANHOLES, SHALL BE TYPE V OR MODIFIED TYPE II PORTLAND CEMENT WITH LESS THAN 5% TRICALCIUM ALUMINATE.
3. MANHOLE RISER SECTIONS, CONES, FLAT TOPS, AND GRADE RINGS SHALL BE PRECAST REINFORCED CONCRETE CONFORMING TO ASTM C-478 OR AASHTO M-199.
4. BACKFILL AROUND MANHOLES AND OTHER STRUCTURES SHALL BE PLACED IN 8" MAX. LIFTS AND COMPACTED TO 95% AASHTO T-99.
5. ALL WORK SHALL BE IN ACCORDANCE WITH APPROVED PLANS AND SPECIFICATIONS.
6. MANHOLE CONE AND FLAT TOP SECTIONS SHALL BE POSITIONED SUCH THAT THE MANHOLE RING AND COVER ARE OFFSET 20 DEGREES TO 30 DEGREES FROM THE UPSTREAM MAIN SEWER LINE INTO THE MANHOLE.
7. MANHOLE STEPS SHALL BE INSTALLED IN VERTICAL ALIGNMENT WITH THE RING AND COVER.
8. MANHOLE RING AND COVER CAN BE SET TO FINISHED GRADE, USING NON-SHRINK GROUT TO ADJUST RING ELEVATION. GROUT SHALL NOT EXCEED .15 FT. THICKNESS AND SHALL HAVE A FINISH COAT OF EPOXY APPLIED TO ALL GROUT SURFACES EXPOSED TO THE INTERIOR OF THE MANHOLE. EPOXY TOP COAT REQUIREMENT MAY BE DELETED PROVIDED NON-SHRINK GROUT IS INSTALLED IN ACCORDANCE WITH MANUFACTURER'S RECOMMENDATIONS AND INSTRUCTIONS AND IS ACCEPTABLE TO THE ENGINEER.
9. STEEL PAVING RINGS ARE NOT ALLOWED FOR GRADE ADJUSTMENT UNLESS OTHERWISE APPROVED BY THE CITY ENGINEER.
10. SEE STANDARD TRENCH DETAIL ON GENERAL NOTES STANDARD DETAIL SHEET FOR TRENCH BACKFILL REQUIREMENTS.

CITY OF FRUITA  
ENGINEERING DEPARTMENT

SCALE  
HORIZONTAL: N/A  
VERTICAL: N/A

REVISION: 2009 STANDARDS REVISION      DATE: 3/18/09  
REVISION: \_\_\_\_\_      DATE: \_\_\_\_\_  
REVISION: \_\_\_\_\_      DATE: \_\_\_\_\_

SANITARY SEWER NOTES

FILE:  
SHEET: 3.9B

DRAWN BY: CLD  
DATE DRAWN: 5/06  
CHECKED BY: \_\_\_\_\_

# CONCRETE ENCASUREMENT

## WATER LINE ABOVE SEWER LINE

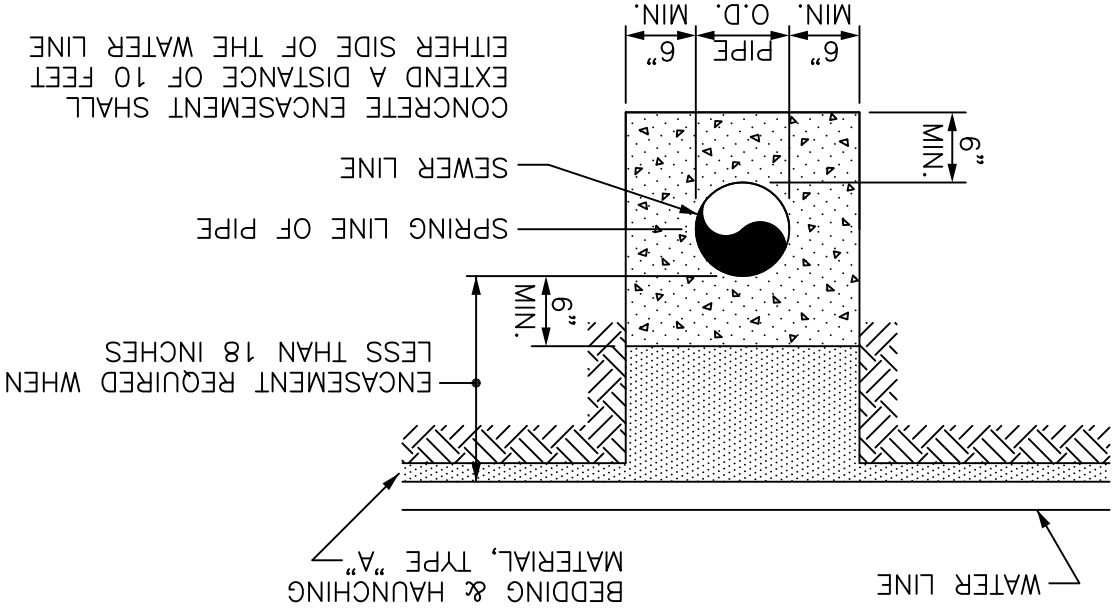

## WATER LINE BELOW SEWER LINE

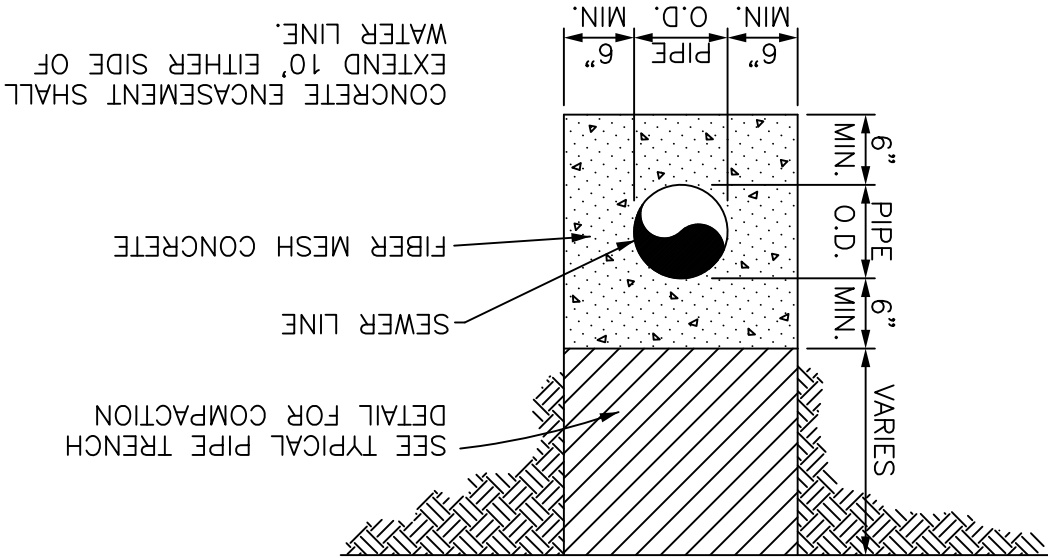

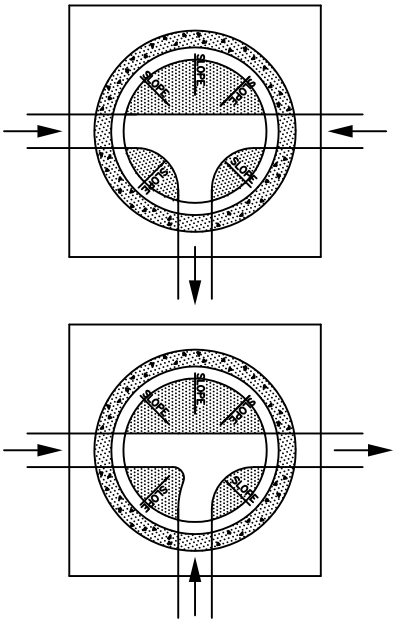

INVERTS SHALL BE FORMED TO PROVIDE A 24" MINIMUM APPROACH IN LINE WITH EACH PIPE FOR MAINTENANCE EQUIPMENT.

SECTION B-B

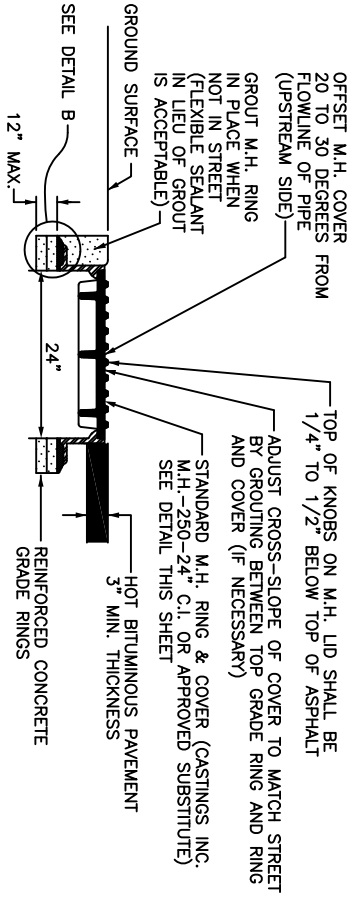

DETAIL "A"

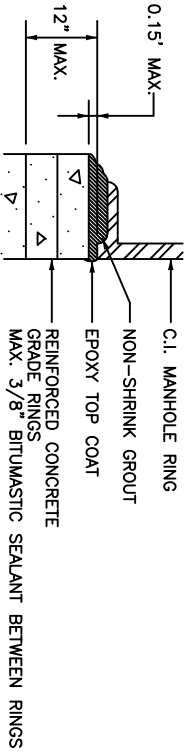

DETAIL "B"

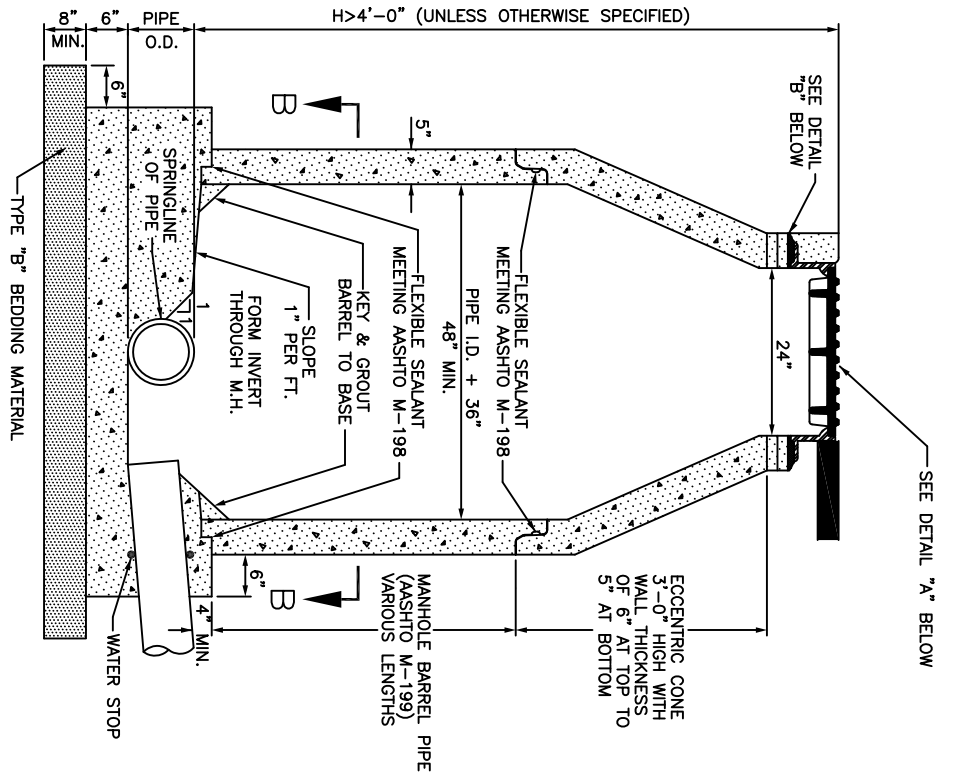

STANDARD MANHOLE  
CAST-IN-PLACE BASE



NOTE:  
DROP MANHOLE SHALL BE PROVIDED WHERE SEWER ENTERS M.H. 2'-0" OR MORE ABOVE LOWEST INVERT OF MANHOLE

DROP MANHOLE  
PRECAST BASE

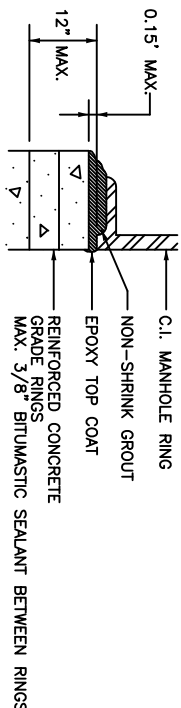
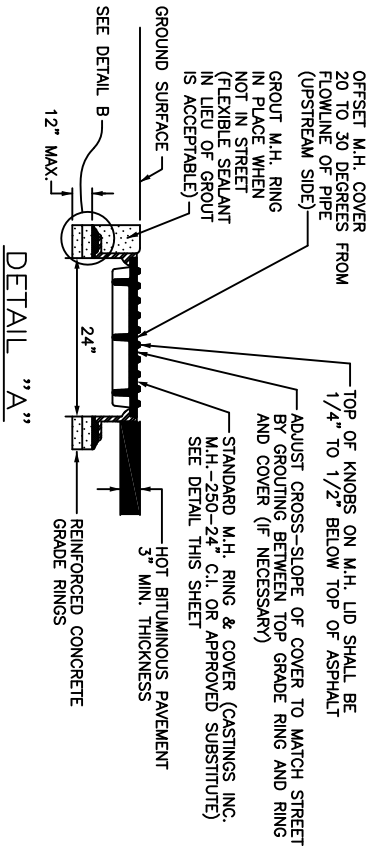
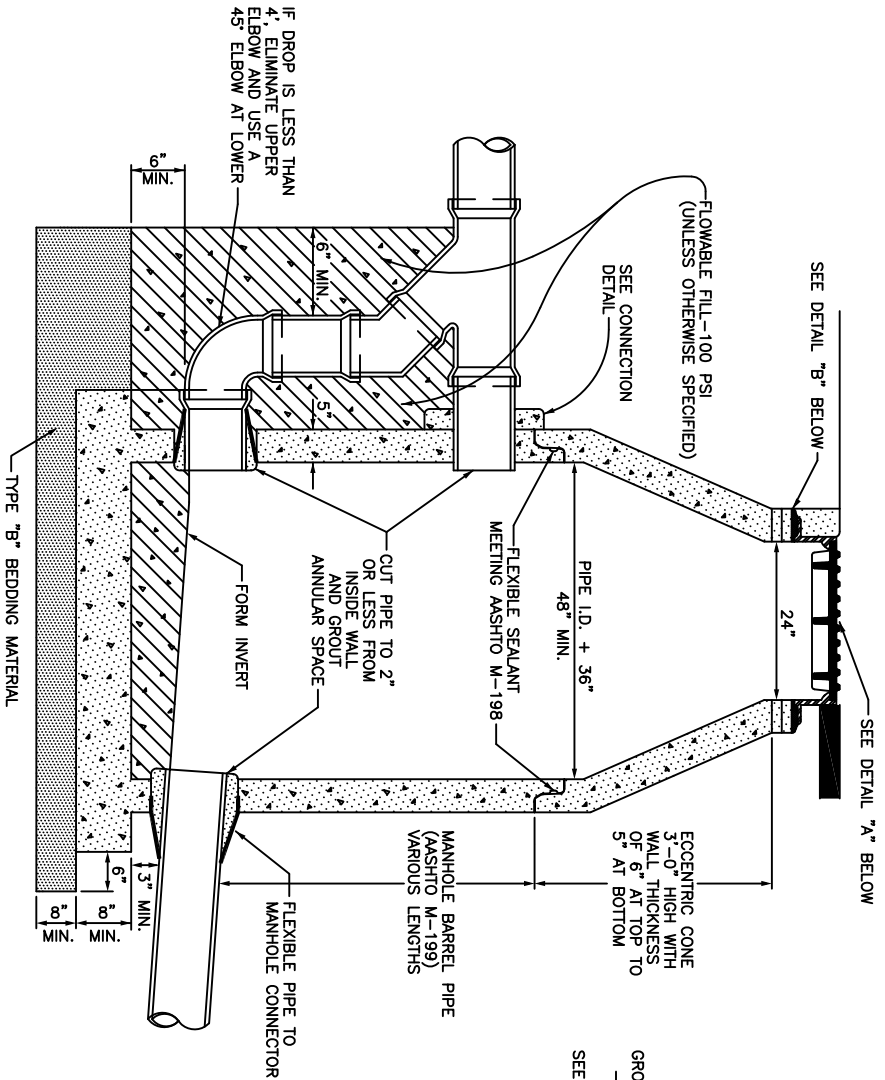

DETAIL "B"

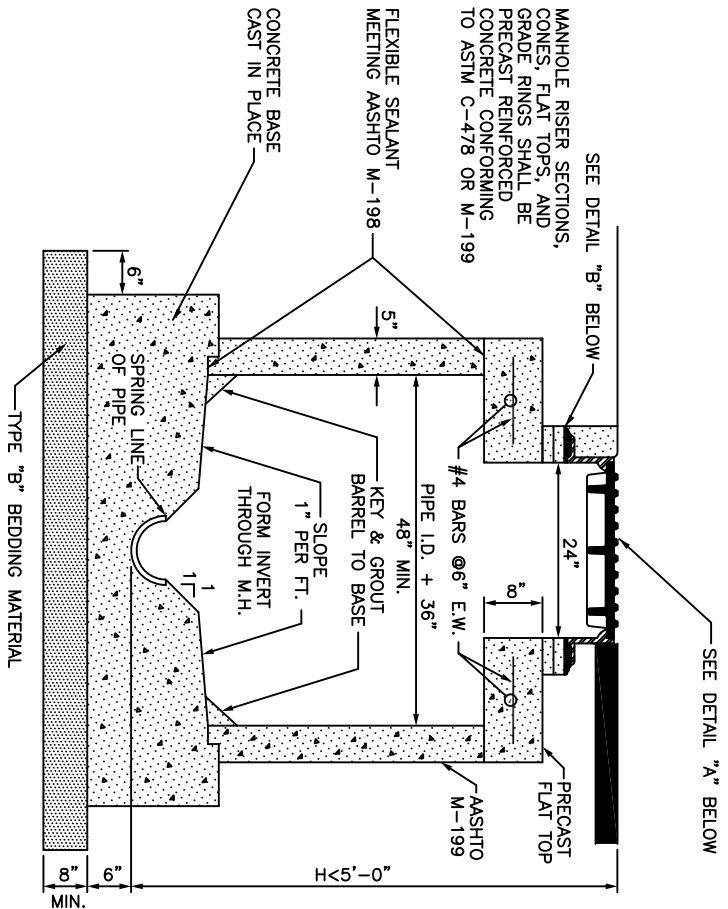

STANDARD SHALLOW MANHOLE  
CAST-IN-PLACE BASE

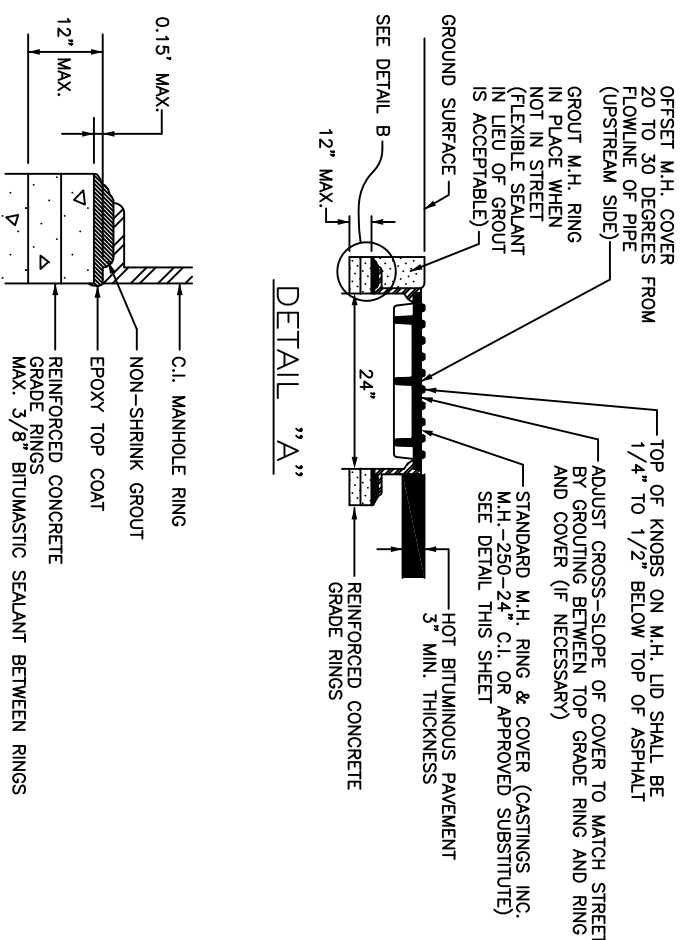

DETAIL "B"

CITY OF FRUITA  
ENGINEERING DEPARTMENT

SCALE  
HORIZONTAL: N/A  
VERTICAL: N/A

REVISION: 2009 STANDARDS REVISION  
REVISION:  
REVISION:

DATE: 3/18/09  
DATE:  
DATE:

SHALLOW MANHOLE  
CAST-IN-PLACE BASE

FILE:  
SHEET: 3.9F

DRAWN BY: CLD  
DATE DRAWN: 5/06  
CHECKED BY:

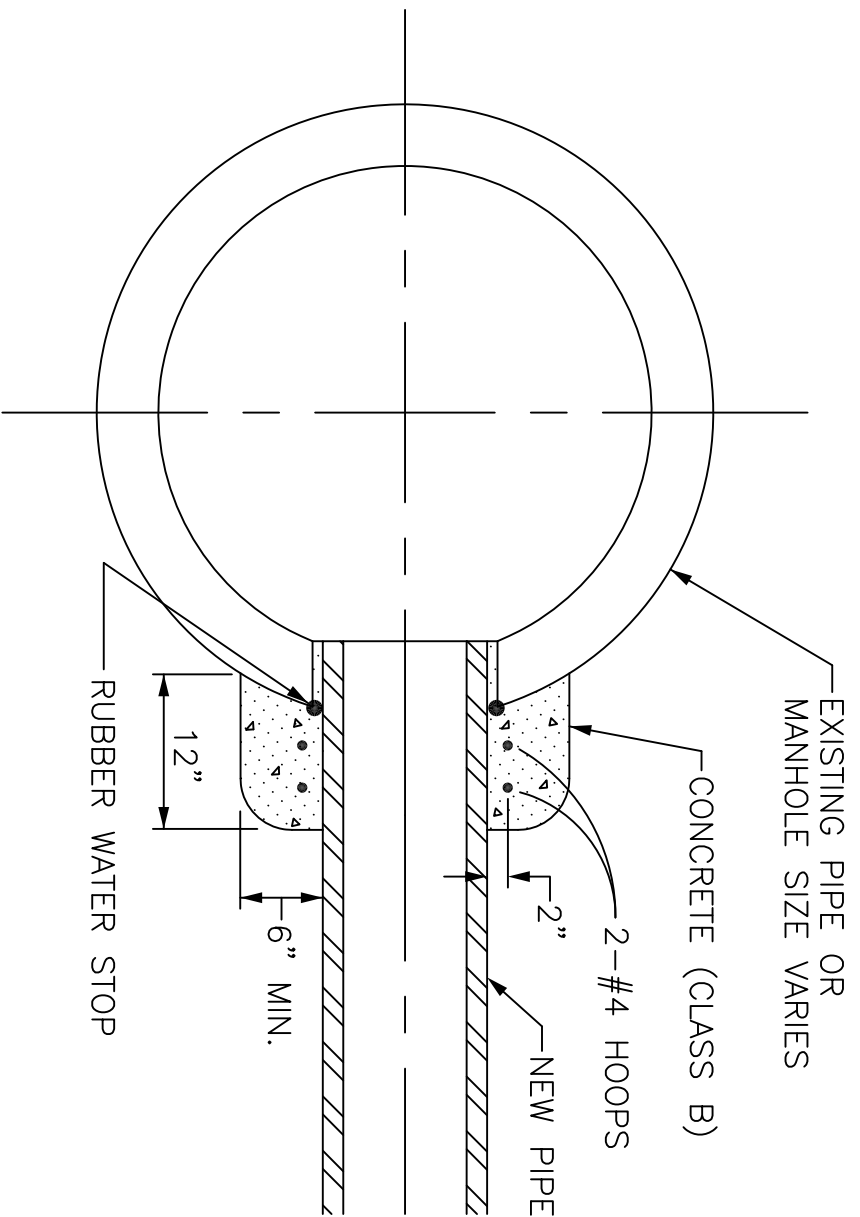

NOTE: IF THE HOLE IN THE EXISTING PIPE OR MANHOLE IS CORED, THE CONNECTION CAN BE MADE BY INSTALLING A FLEXIBLE PIPE TO MANHOLE CONNECTOR ("BOOT") AND THE CONCRETE ENCASEMENT ELIMINATED.

CONNECTION TO EXISTING  
MANHOLE

CITY OF FRUITA  
ENGINEERING DEPARTMENT

SCALE  
HORIZONTAL: N/A  
VERTICAL: N/A

REVISION: 2009 STANDARDS REVISION  
REVISION: \_\_\_\_\_  
REVISION: \_\_\_\_\_

DATE: 3/18/09  
DATE: \_\_\_\_\_  
DATE: \_\_\_\_\_

CONNECTION TO EXISTING  
MANHOLE

FILE:  
SHEET: 396

DRAWN BY: CLD  
DATE DRAWN: 5/06  
CHECKED BY: \_\_\_\_\_

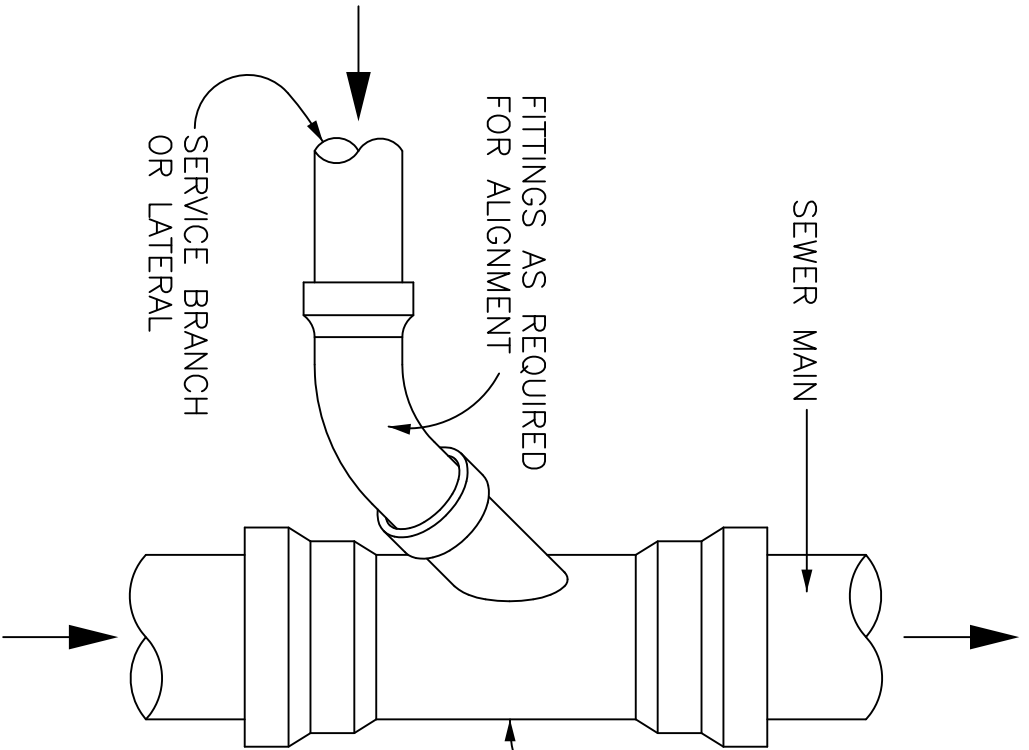

PLAN

WYE FITTING ON NEW INSTALLATIONS. INSERTA TEE (OR EQUIVALENT) FOR NEW CONNECTIONS TO EXISTING MAINS.

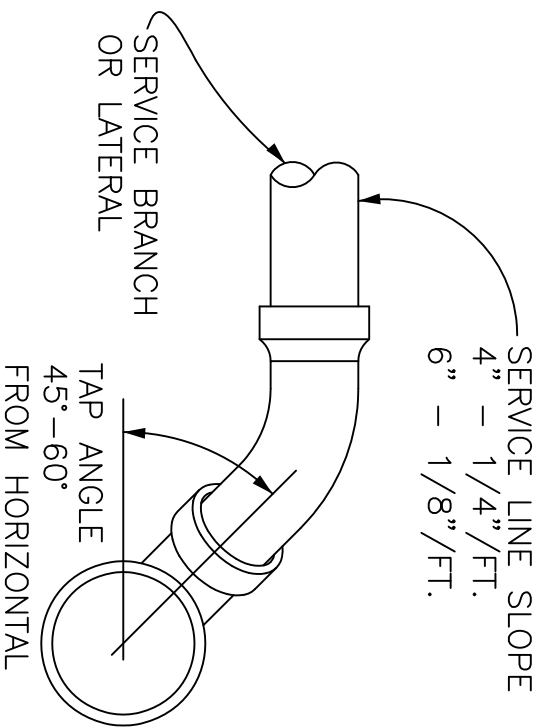

ELEVATION

TYPICAL SERVICE "Y" CONNECTION

CITY OF FRUITA  
ENGINEERING DEPARTMENT

SCALE  
HORIZONTAL: N/A  
VERTICAL: N/A

REVISION: 2009 STANDARDS REVISION DATE: 3/18/09  
REVISION: \_\_\_\_\_ DATE: \_\_\_\_\_  
REVISION: \_\_\_\_\_ DATE: \_\_\_\_\_

TYPICAL "Y" SERVICE  
CONNECTION

FILE:  
SHEET: 3.9H

DRAWN BY: CLD  
DATE DRAWN: 5/06  
CHECKED BY: \_\_\_\_\_

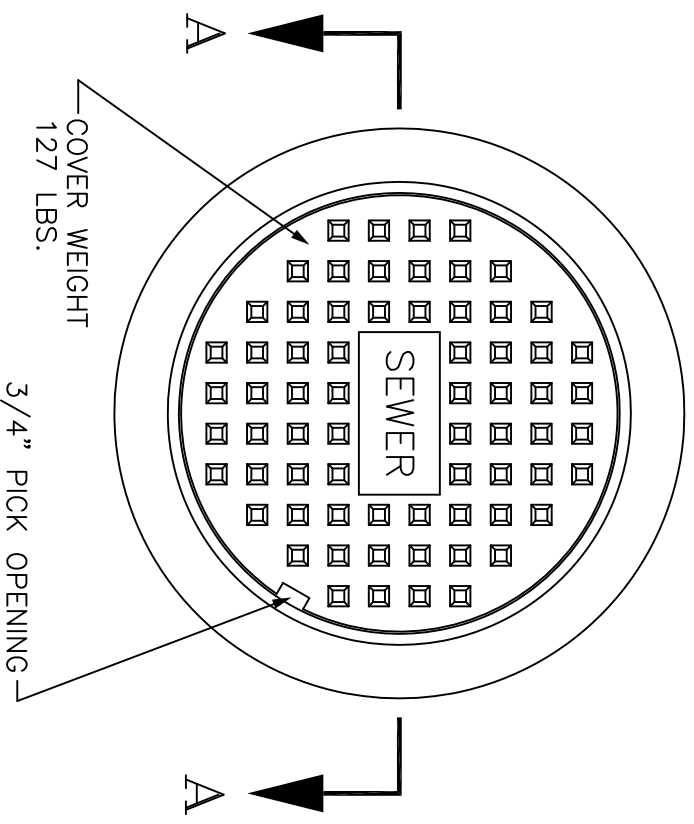
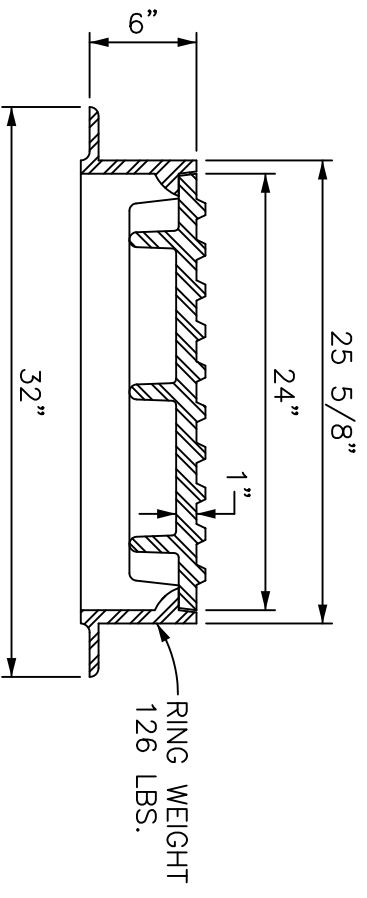

STANDARD CAST IRON  
MANHOLE RING & COVER

CITY OF FRUITA  
ENGINEERING DEPARTMENT

SCALE  
HORIZONTAL: N/A  
VERTICAL: N/A

REVISION: 2009 STANDARDS REVISION  
REVISION: \_\_\_\_\_  
REVISION: \_\_\_\_\_

DATE: 3/18/09  
DATE: \_\_\_\_\_  
DATE: \_\_\_\_\_

MANHOLE RING & COVER

FILE:  
SHEET: 3.91

DRAWN BY: CLD  
DATE DRAWN: 5/06  
CHECKED BY: \_\_\_\_\_

STANDARD SEWER CLEANOUT  
(IN PAVEMENT OR CONCRETE)

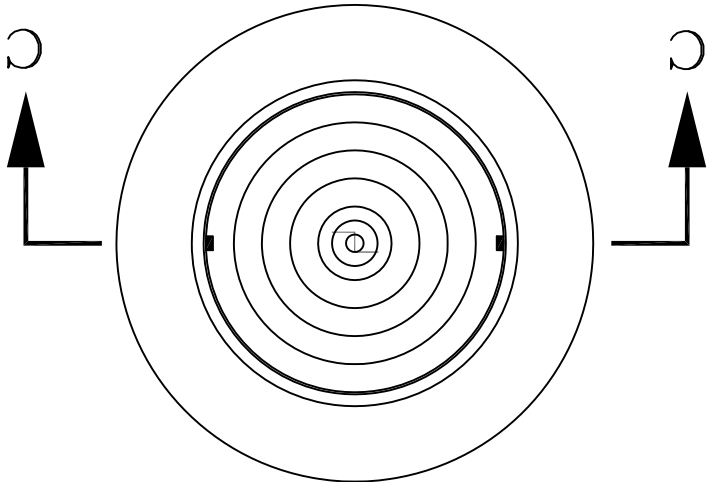

SECTION C-C

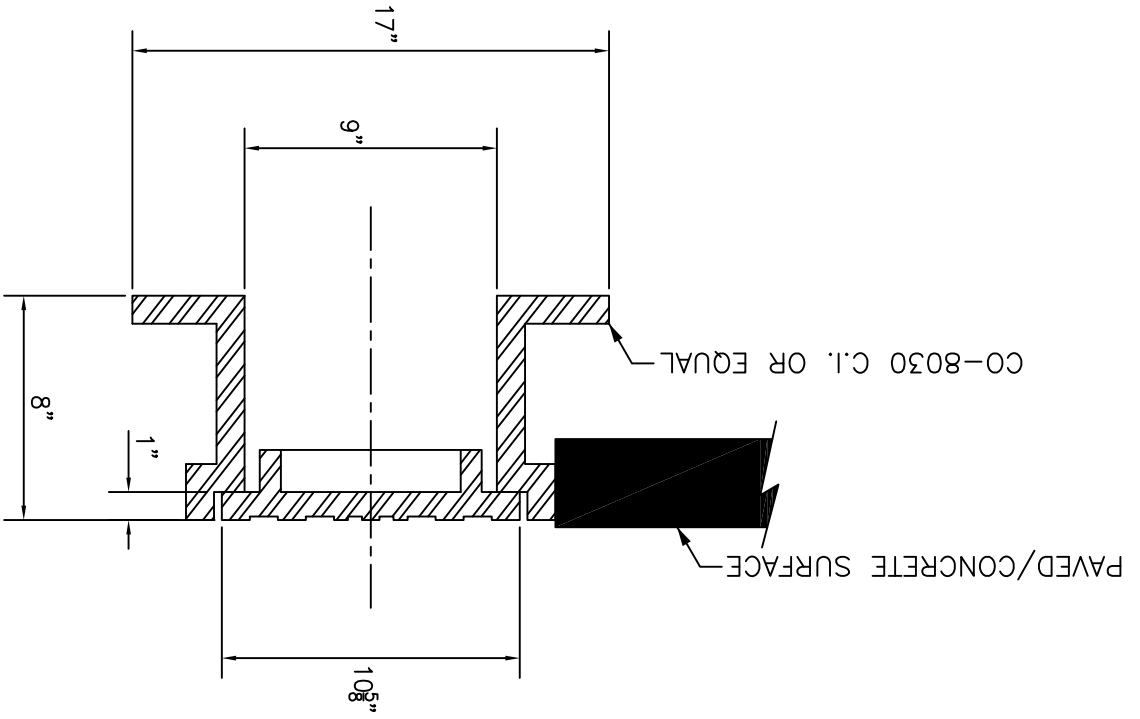

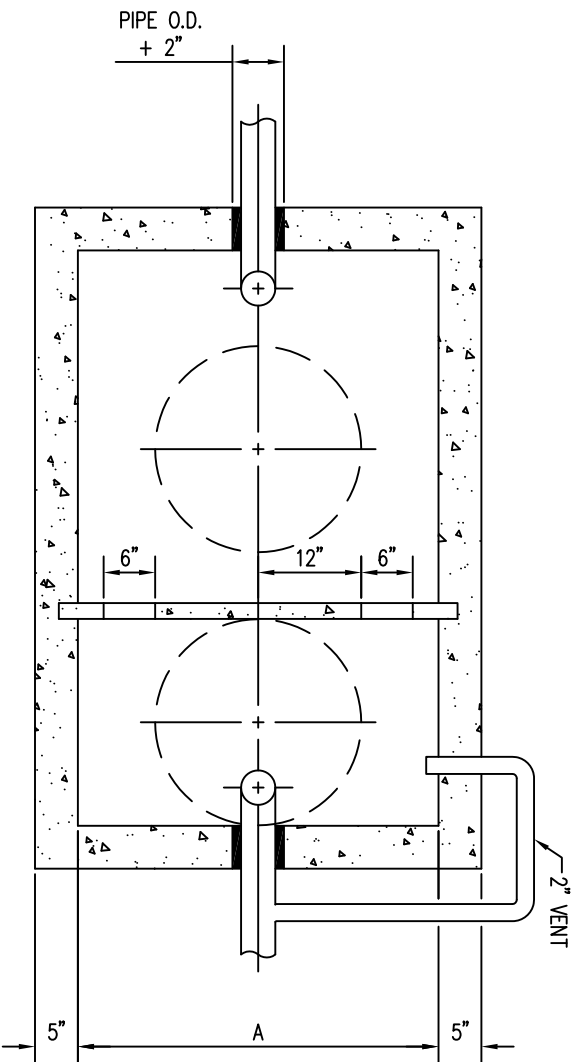

PLAN

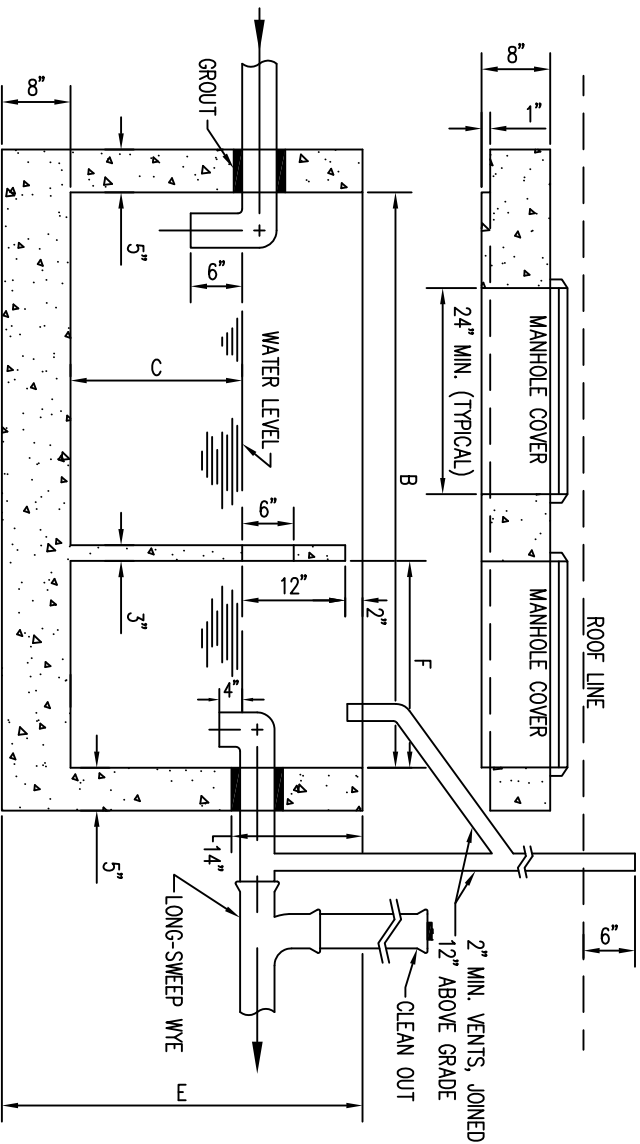

SECTION

- SAND & OIL INTERCEPTOR NOTES:
1. ALL PIPE & FITTINGS SHALL BE CAST IRON, 3" MIN. DIAMETER.
  2. SMALL COMPARTMENT HAS 3/4 OF THE TOTAL CAPACITY.
  3. WALLS & BOTTOM REINFORCED THROUGHOUT WITH 2X16 #6 REMESH.
  4. COVERS TO BE REINFORCED LONGITUDINALLY WITH NO. 6 REBAR ON 6" CENTERS, NO. 4 REBAR ON 6" CENTERS WIDTHWISE, & NO. 8 REBAR DIAGONALLY AROUND ACCESS HOLES.
  5. CLEAN OUT SHALL BE AN IRON BODY FERRULE WITH BRASS SCREW PLUG.
  6. VENT PIPE SHALL BE CAST IRON TO A POINT 6" ABOVE GROUND.
  7. MANHOLE RING AND COVER SHALL BE J-MARK NO. 1161 OR EQUAL.
  8. CHECK WITH SUPPLIER FOR EXACT DIMENSIONS.
  9. NO BOLT DOWN COVERS ALLOWED WITHOUT PERMISSION FROM CITY OF FRUITA ENGINEERING DEPARTMENT.

COMMERCIAL INTERCEPTOR

WATER CAPACITY (APPROX.) GALLONS	DIMENSIONS					
	TWO COMPARTMENT TANK (INCHES)					
	A	B	C	D	E	F
320	48	72	22	30	44	24
500	48	72	36	46	58	24
780	48	96	40	48	62	20
1060	72	102	34	42	56	30

SAND & OIL INTERCEPTOR, TYPE "A" COMMERCIAL

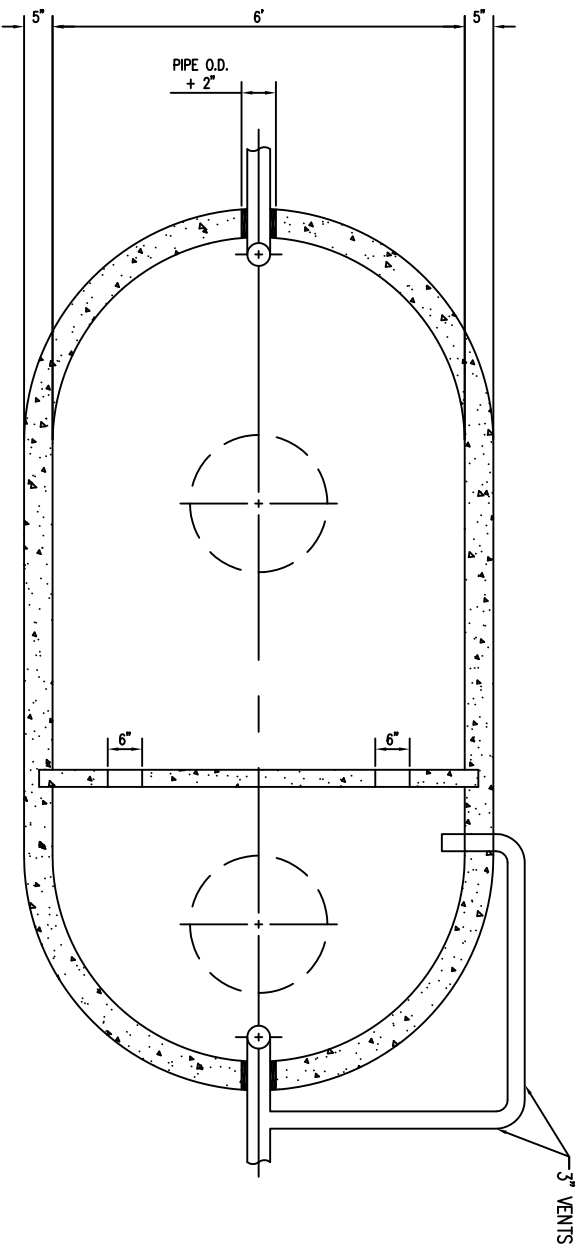

PLAN

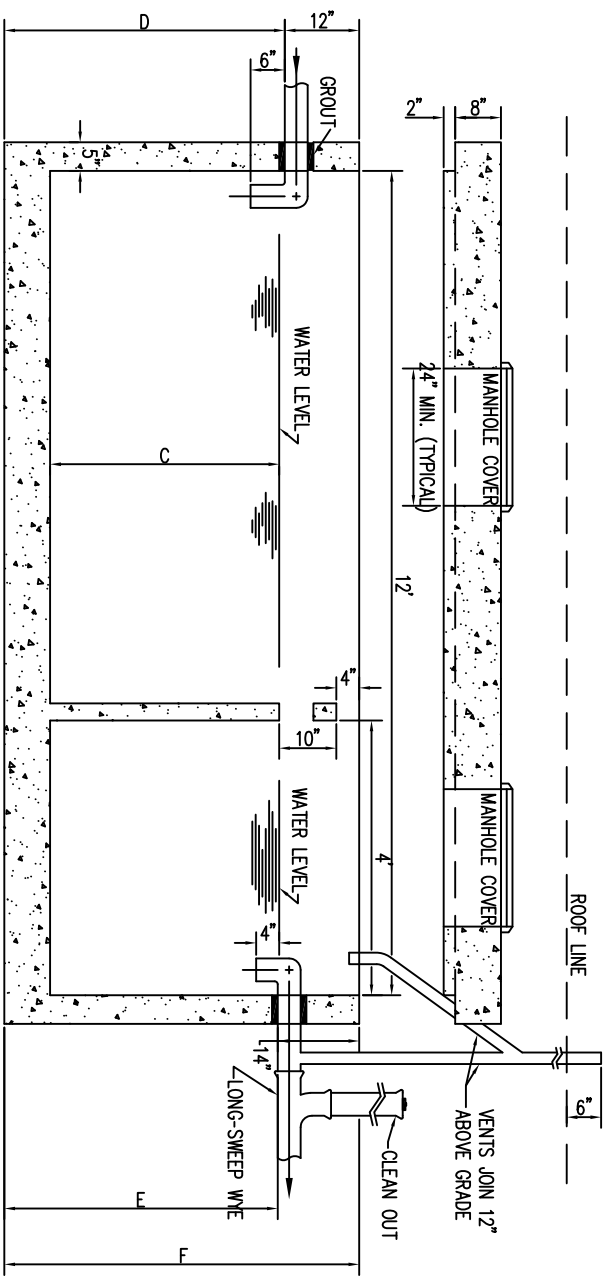

SECTION

- SAND & OIL INTERCEPTOR NOTES:
1. ALL PIPE & FITTINGS SHALL BE CAST IRON, 3" MIN. DIAMETER.
  2. SMALL COMPARTMENT HAS 1/3 OF THE TOTAL CAPACITY.
  3. WALLS & BOTTOM REINFORCED THROUGHOUT WITH 2X16 #6 REMESH.
  4. COVERS TO BE REINFORCED LONGITUDINALLY WITH NO. 6 REBAR ON 6" CENTERS, NO. 4 REBAR ON 6" CENTERS WIDTHWISE, & NO. 8 REBAR DIAGONALLY AROUND ACCESS HOLES.
  5. CLEAN OUT SHALL BE AN IRON BODY FERRULE WITH BRASS SCREW PLUG.
  6. VENT PIPE SHALL BE CAST IRON TO A POINT 6" ABOVE GROUND.
  7. MANHOLE RING AND COVER SHALL BE J-MARK NO. 1161 OR EQUAL.
  8. CHECK WITH SUPPLIER FOR EXACT DIMENSIONS.
  9. NO BOLT DOWN COVERS ALLOWED WITHOUT PERMISSION FROM CITY OF FRUITA ENGINEERING DEPARTMENT.

SAND & OIL INTERCEPTOR, TYPE "B" INDUSTRIAL

WATER CAPACITY (APPROX.) GALLONS	DIMENSIONS			
	C	D	E	F
1565	40	50	48	62
1800	46	56	54	68
2035	52	62	60	74
2505	64	74	72	86
2975	76	86	84	98
3210	82	92	90	104
3445	88	98	96	110

INDUSTRIAL INTERCEPTOR



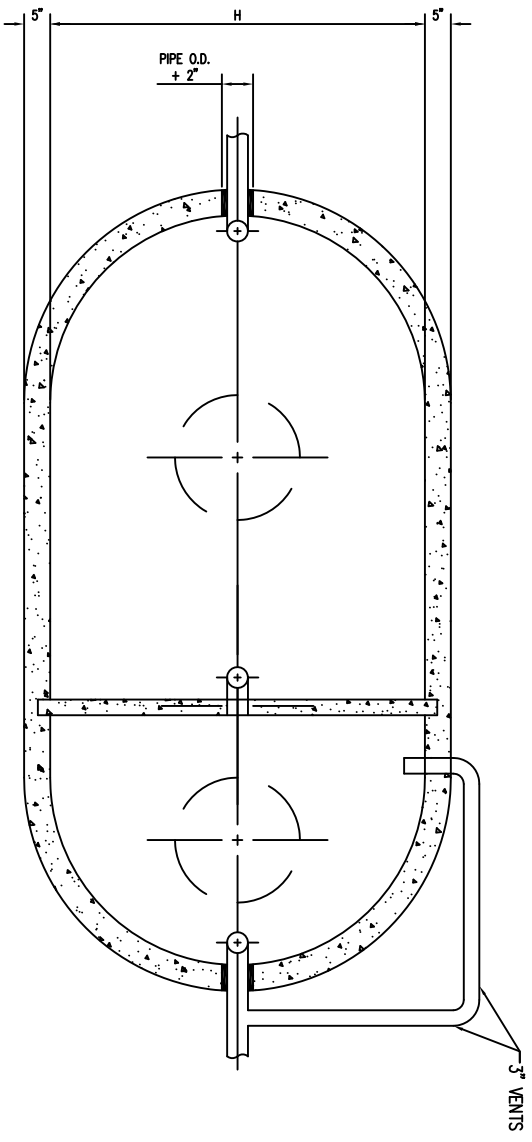

PLAN

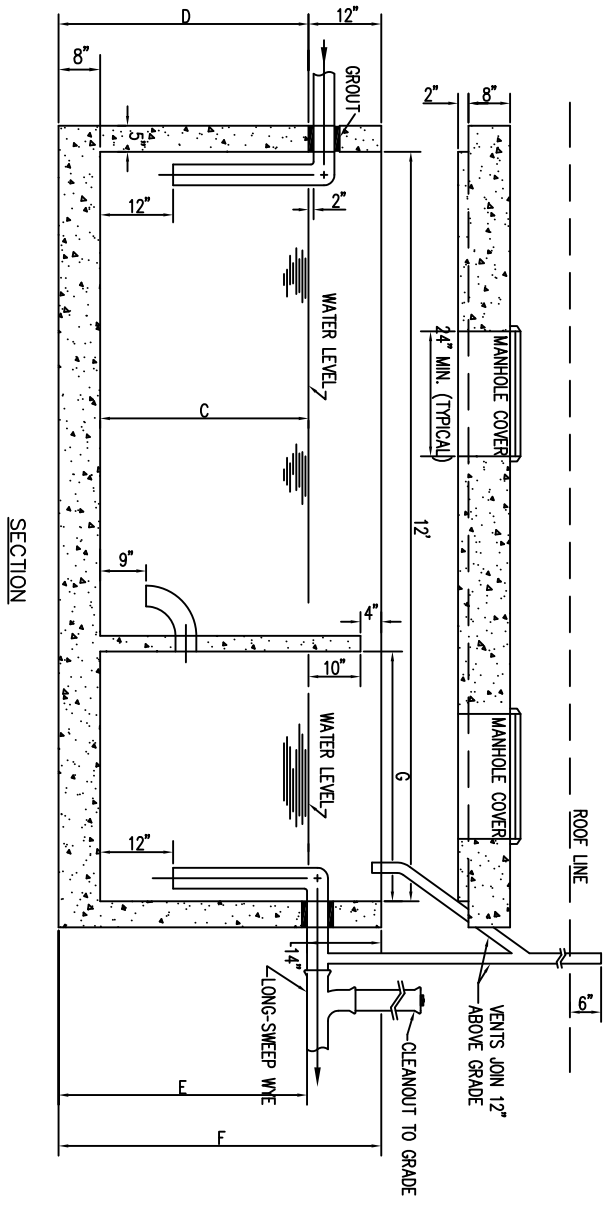

SECTION

COMMERCIAL GREASE INTERCEPTOR

- GREASE INTERCEPTOR NOTES:
1. ALL PIPE & FITTINGS SHALL BE PVC, 4" MIN. DIAMETER.
  2. SMALL COMPARTMENT HAS 3/10 OF THE TOTAL CAPACITY.
  3. WALLS & BOTTOM REINFORCED THROUGHOUT WITH 2X16 #8 REMESH.
  4. COVERS TO BE REINFORCED LONGITUDINALLY WITH NO. 6 REBAR ON 6" CENTERS, NO. 4 REBAR ON 6" CENTERS WIDTHWISE, & NO. 8 REBAR DIAGONALLY AROUND ACCESS HOLES.
  5. CLEAN OUT SHALL BE PVC WITH SCREW CAP.
  6. VENT PIPE SHALL BE PVC TO A POINT 6" ABOVE ROOF LINE.
  7. MANHOLE RING AND COVER SHALL BE J-MARK NO. 1161 OR EQUAL.
  8. CHECK WITH SUPPLIER FOR EXACT DIMENSIONS.
  9. NO BOLT DOWN COVERS ALLOWED WITHOUT PERMISSION FROM CITY OF FRUITA PUBLIC WORKS DEPARTMENT.
  10. GREASE CAPACITY RATED FOR LARGE COMPARTMENT ONLY.

COMMERCIAL GREASE INTERCEPTOR

ESTIMATED BUILDING SIZE	WATER CAPACITY (APPROX.) GALLONS	GREASE CAPACITY (APPROX.) CUBIC FT.	DIMENSIONS (INCHES)							
			C	D	E	F	G	H		
UP TO 2,000 SQ. FT.	320	17	22	32	30	44	24	48		
UP TO 3,000 SQ. FT.	500	32	36	46	44	58	24	48		
UP TO 5,000 SQ. FT.	750	47	40	48	46	62	20	48		
UP TO 10,000 SQ. FT.	1060	74	34	42	40	56	30	72		
OVER 10,000 SQ. FT.	1260	87	35	43	41	57	36	80		
UP TO 5,000 SQ. FT.	1565	100	40	50	48	62	48	72		
UP TO 10,000 SQ. FT.	1800	121	46	56	54	68	48	72		
UP TO 15,000 SQ. FT.	2035	143	52	62	60	74	48	72		
UP TO 25,000 SQ. FT.	2505	186	64	74	72	86	48	72		
UP TO 35,000 SQ. FT.	2975	229	76	86	84	98	48	72		
UP TO 50,000 SQ. FT.	3210	250	82	92	90	104	48	72		
OVER 50,000 SQ. FT.	3445	271	88	98	96	110	48	72		

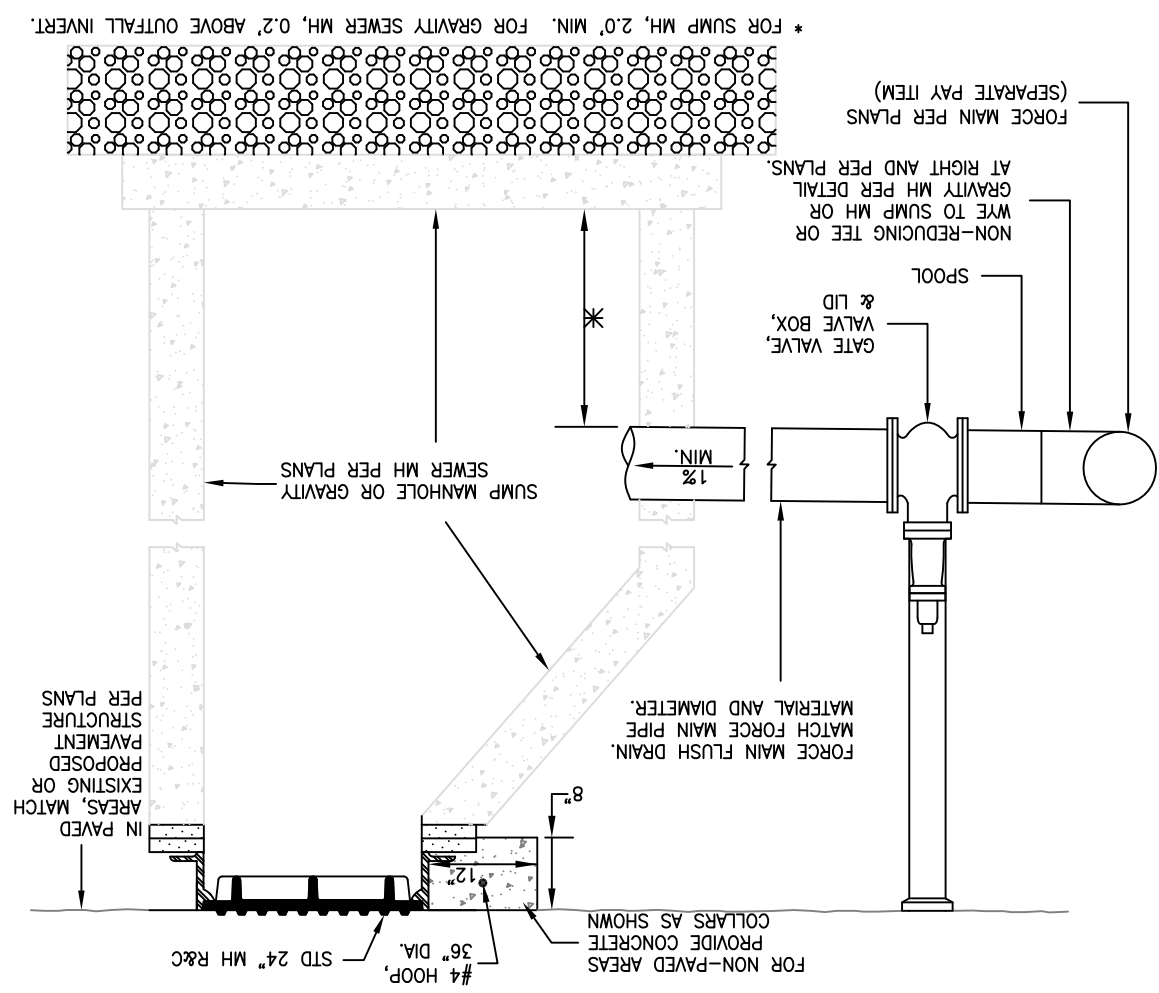
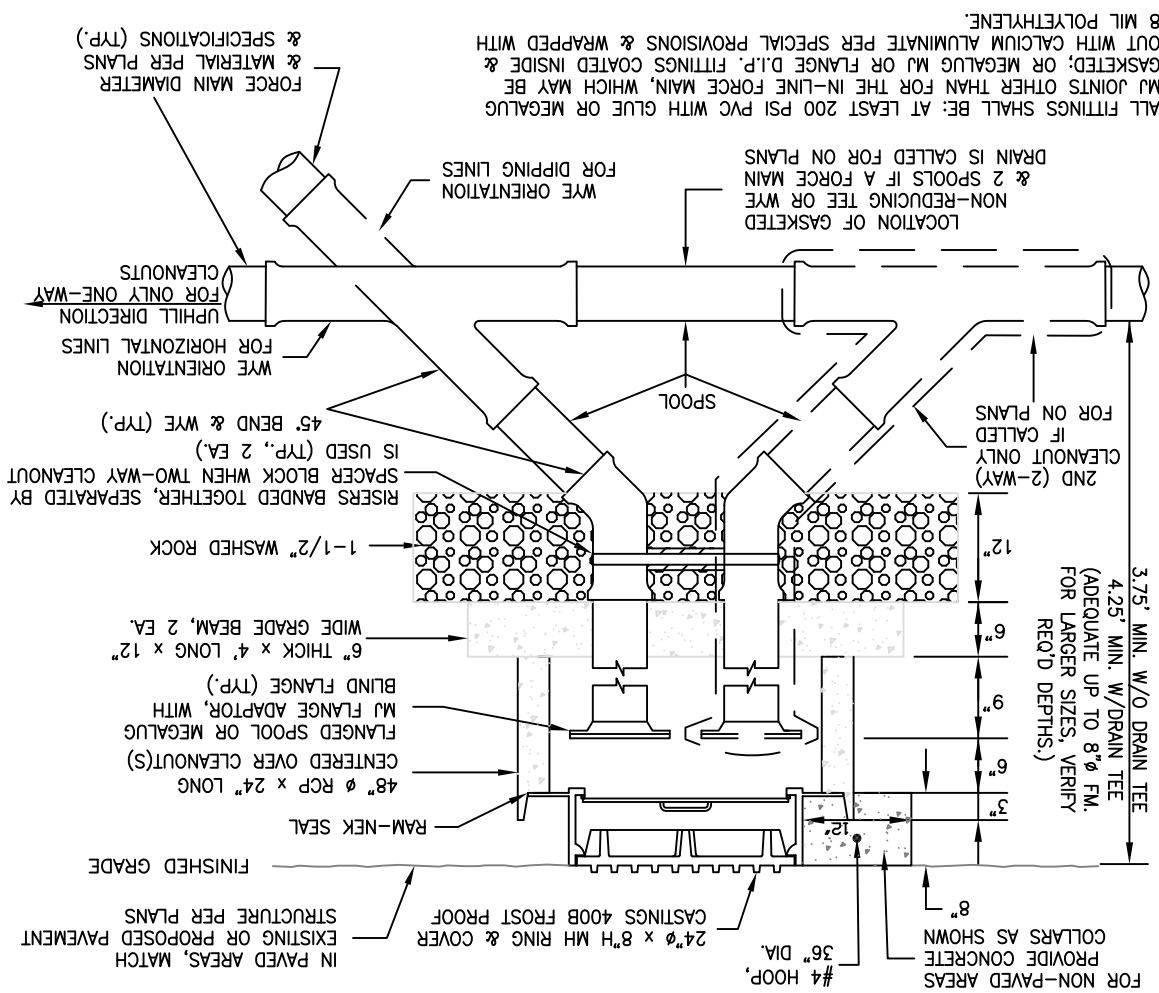

ALL FITTINGS SHALL BE: AT LEAST 200 PSI PVC WITH GLUE OR MEGALUG  
GASKETED; OR MEGALUG MJ OR FLANGE D.I.P. FITTINGS COATED INSIDE &  
OUT WITH CALCIUM ALUMINATE PER SPECIAL PROVISIONS & WRAPPED WITH  
8 MIL POLYETHYLENE.

LOCATION OF GASKETED  
NON-REDUCING TEE OR WYE  
& 2 SPOOLS IF A FORCE MAIN  
DRAIN IS CALLED FOR ON PLANS

WYE ORIENTATION  
FOR DIPPING LINES  
UPHILL DIRECTION  
FOR ONLY ONE-WAY  
CLEANOUTS  
WYE ORIENTATION  
FOR HORIZONTAL LINES

2ND (2-WAY)  
CLEANOUT ONLY  
IF CALLED  
FOR ON PLANS

SPACER Banded TOGETHER, SEPARATED BY  
SPACER BLOCK WHEN TWO-WAY CLEANOUT  
IS USED (TYP. 2 EA.)  
45° BEND & WYE (TYP.)

6" THICK x 4' LONG x 12"  
WIDE GRADE BEAM, 2 EA.

48" Ø RCP x 24" LONG  
CENTERED OVER CLEANOUT(S)  
FLANGED SPOOL OR MEGALUG  
MJ FLANGE ADAPTOR, WITH  
BLIND FLANGE (TYP.)

3.75' MIN. W/O DRAIN TEE  
(ADEQUATE UP TO 8" Ø FM,  
FOR LARGER SIZES, VERIFY  
RECD DEPTHS.)

FOR NON-PAVED AREAS  
PROVIDE CONCRETE  
COLLARS AS SHOWN  
8"  
#4 HOOP,  
36" DIA.  
CASTINGS 400B FROST PROOF  
EXISTING OR PROPOSED PAVEMENT  
STRUCTURE PER PLANS  
FINISHED GRADE  
RAM-NEK SEAL

\* FOR SUMP MH, 2.0' MIN. FOR GRAVITY SEWER MH, 0.2' ABOVE OUTFALL INVERT.

FORCE MAIN PER PLANS  
(SEPARATE PAY ITEM)

AT RIGHT AND PER PLANS,  
GRAVITY MH PER DETAIL

WYE TO SUMP MH OR  
NON-REDUCING TEE OR  
SPOOL

GATE VALVE,  
VALVE BOX,  
& LID

SUMP MANHOLE OR GRAVITY  
SEWER MH PER PLANS

FORCE MAIN FLUSH DRAIN,  
MATCH FORCE MAIN PIPE,  
MATERIAL AND DIAMETER.

IN PAVED  
AREAS, MATCH  
EXISTING OR  
PROPOSED  
PAVEMENT  
STRUCTURE  
PER PLANS

8"  
12"  
36" DIA.  
#4 HOOP,  
STD 24" MH R&C

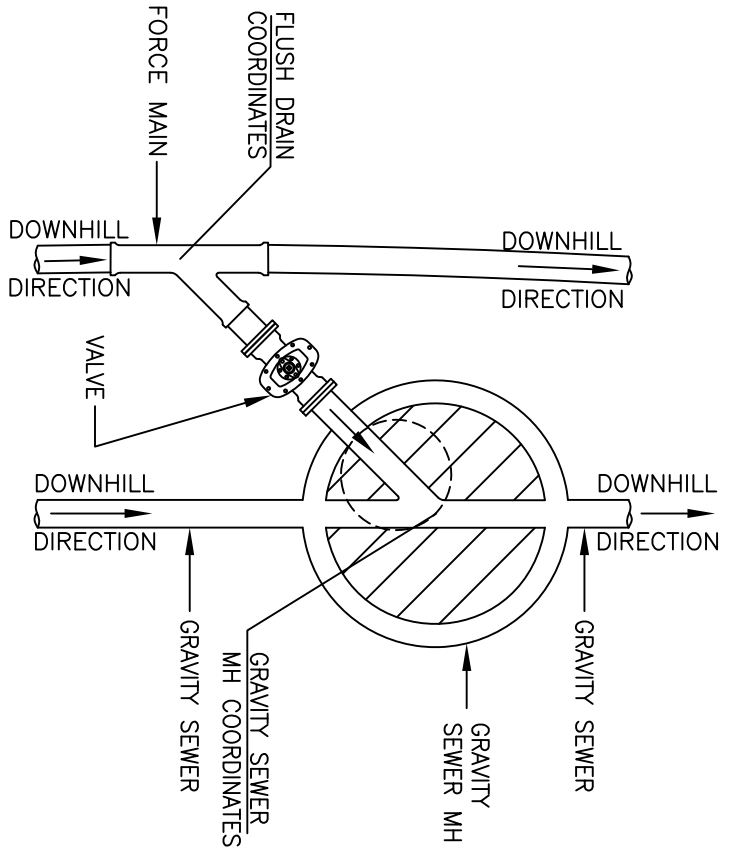
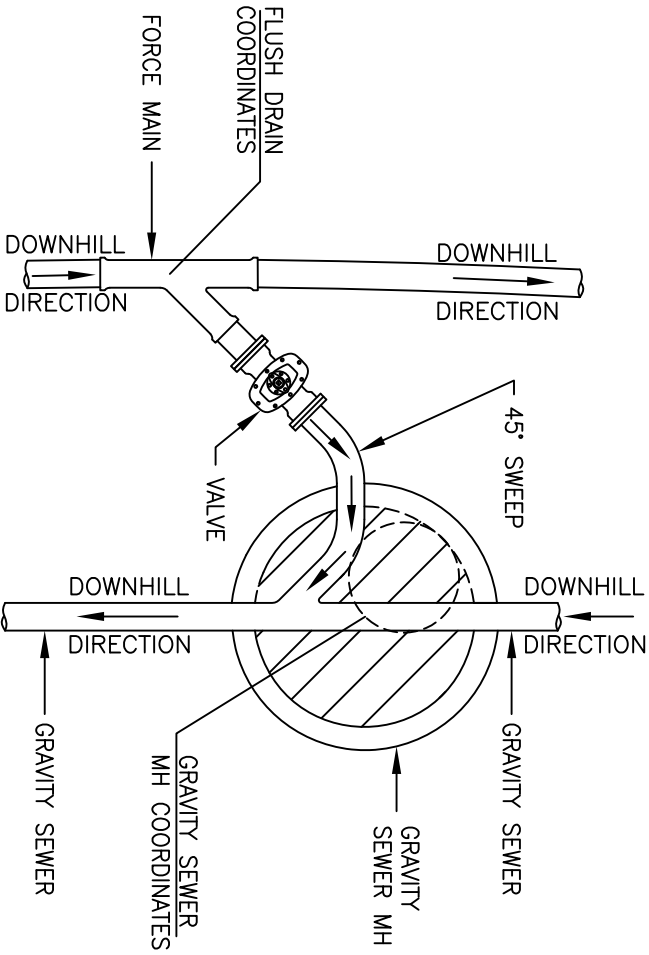
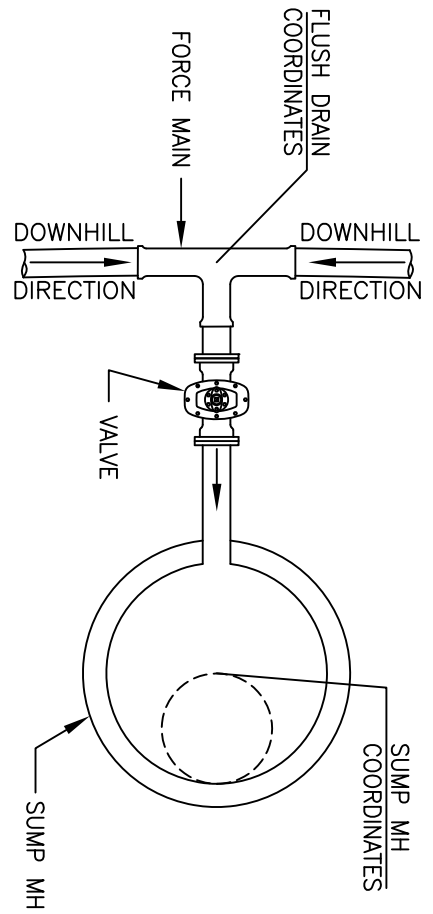
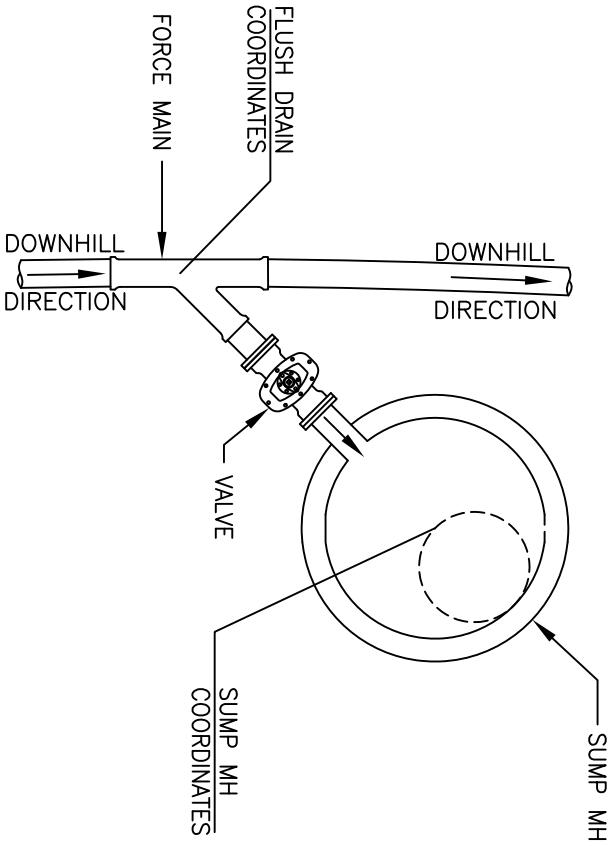

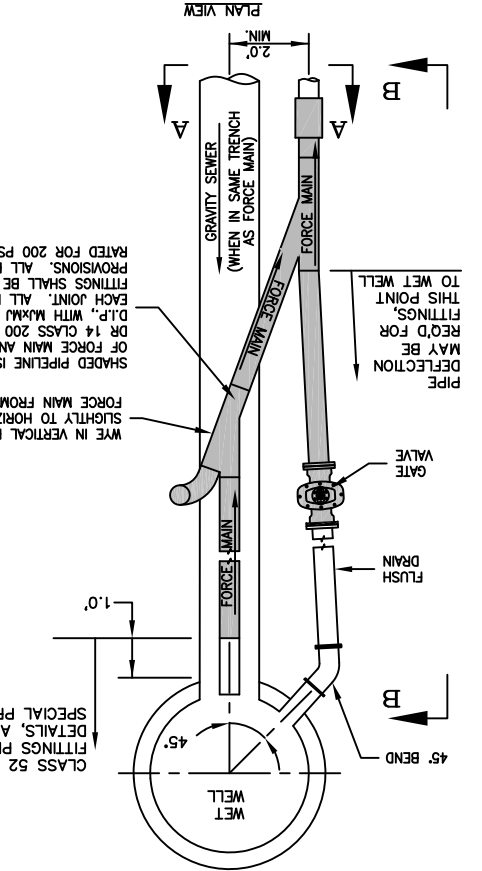
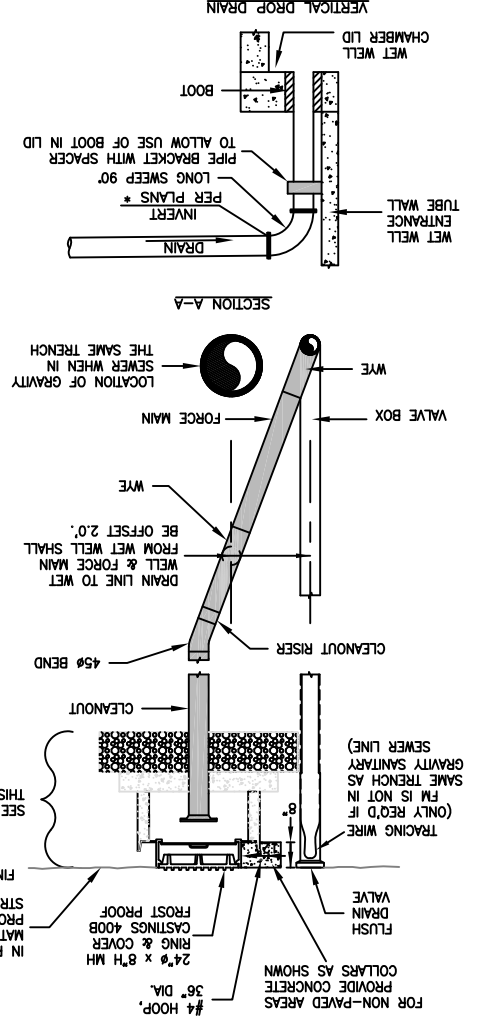
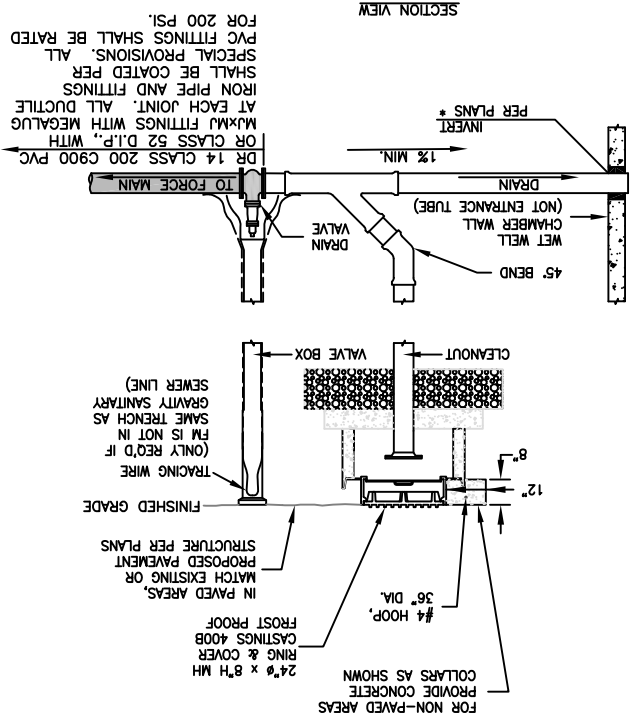
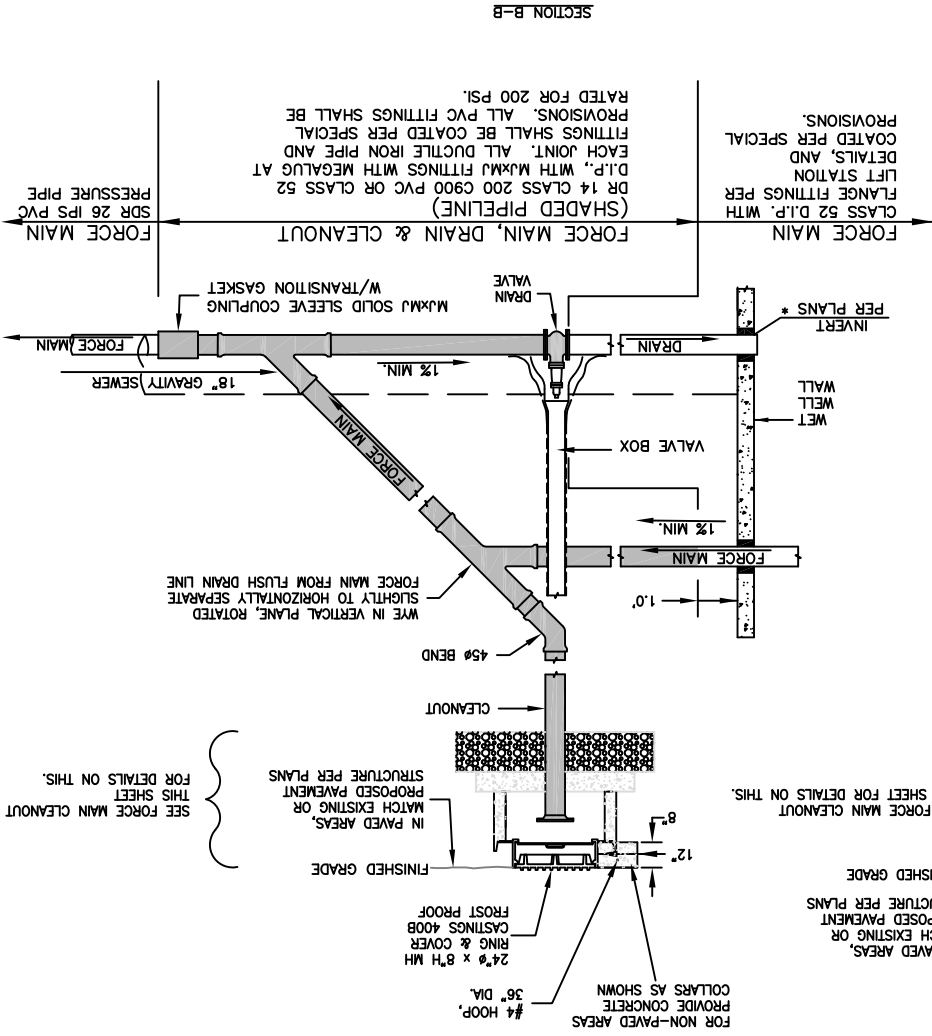

SECTION B-B

FORCE MAIN, DRAIN & CLEANOUT (SHADED PIPELINE)  
CLASS 52 D.I.P. WITH FLANGE FITTINGS PER LIFT STATION DETAILS, AND COATED PER SPECIAL PROVISIONS.

DR 14 CLASS 200 C900 PVC OR CLASS 52 D.I.P. WITH M&M J FITTINGS WITH MEGALUG AT EACH JOINT. ALL DUCTILE IRON PIPE AND FITTINGS SHALL BE COATED PER SPECIAL PROVISIONS. ALL PVC FITTINGS SHALL BE RATED FOR 200 PSI.

WYE IN VERTICAL PLANE, ROTATED SLIGHTLY TO HORIZONTALLY SEPARATE FORCE MAIN FROM FLUSH DRAIN LINE

FOR NON-PAVED AREAS PROVIDE CONCRETE COLLARS AS SHOWN #4 HOOP, 36" DIA.

IN PAVED AREAS, MATCH EXISTING OR PROPOSED PAVEMENT STRUCTURE PER PLANS

FINISHED GRADE

TRACING WIRE (ONLY READ IF FIM IS NOT IN SAME TRENCH AS GRAVITY SANITARY SEWER LINE)

FLUSH DRAIN VALVE

FOR NON-PAVED AREAS PROVIDE CONCRETE COLLARS AS SHOWN #4 HOOP, 36" DIA.

RING & COVER CASTINGS 400B FROST PROOF

IN PAVED AREAS, MATCH EXISTING OR PROPOSED PAVEMENT STRUCTURE PER PLANS

FINISHED GRADE

SEE FORCE MAIN CLEANOUT ON THIS SHEET FOR DETAILS ON THIS.

SEE FORCE MAIN CLEANOUT ON THIS SHEET FOR DETAILS ON THIS.

SECTION A-A

WET WELL CHAMBER LID

BOOT

PIPE BRACKET WITH SPACER

LONG SWEEP 90°

PER PLANS \* INVERT

DRAIN

WET WELL ENTRANCE TUBE WALL

WET WELL

LOCATION OF GRAVITY SEWER WHEN IN THE SAME TRENCH

WYE

WET WELL CHAMBER LID

BE OFFSET 2.0' FROM WET WELL SHALL WELL & FORCE MAIN

DRAIN LINE TO WET WELL

CLEANOUT RISER

45° BEND

FINISHED GRADE

TRACING WIRE (ONLY READ IF FIM IS NOT IN SAME TRENCH AS GRAVITY SANITARY SEWER LINE)

FLUSH DRAIN VALVE

FOR NON-PAVED AREAS PROVIDE CONCRETE COLLARS AS SHOWN #4 HOOP, 36" DIA.

RING & COVER CASTINGS 400B FROST PROOF

IN PAVED AREAS, MATCH EXISTING OR PROPOSED PAVEMENT STRUCTURE PER PLANS

FINISHED GRADE

SEE FORCE MAIN CLEANOUT ON THIS SHEET FOR DETAILS ON THIS.

SEE FORCE MAIN CLEANOUT ON THIS SHEET FOR DETAILS ON THIS.

PLAN VIEW

WET WELL CHAMBER LID

BOOT

PIPE BRACKET WITH SPACER

LONG SWEEP 90°

PER PLANS \* INVERT

DRAIN

WET WELL ENTRANCE TUBE WALL

WET WELL

LOCATION OF GRAVITY SEWER WHEN IN THE SAME TRENCH

WYE

WET WELL CHAMBER LID

BE OFFSET 2.0' FROM WET WELL SHALL WELL & FORCE MAIN

DRAIN LINE TO WET WELL

CLEANOUT RISER

45° BEND

FINISHED GRADE

TRACING WIRE (ONLY READ IF FIM IS NOT IN SAME TRENCH AS GRAVITY SANITARY SEWER LINE)

FLUSH DRAIN VALVE

FOR NON-PAVED AREAS PROVIDE CONCRETE COLLARS AS SHOWN #4 HOOP, 36" DIA.

RING & COVER CASTINGS 400B FROST PROOF

IN PAVED AREAS, MATCH EXISTING OR PROPOSED PAVEMENT STRUCTURE PER PLANS

FINISHED GRADE

SEE FORCE MAIN CLEANOUT ON THIS SHEET FOR DETAILS ON THIS.

SEE FORCE MAIN CLEANOUT ON THIS SHEET FOR DETAILS ON THIS.

SECTION VIEW

FORCE MAIN, DRAIN & CLEANOUT (SHADED PIPELINE)  
CLASS 52 D.I.P. WITH FLANGE FITTINGS PER LIFT STATION DETAILS, AND COATED PER SPECIAL PROVISIONS.

DR 14 CLASS 200 C900 PVC OR CLASS 52 D.I.P. WITH M&M J FITTINGS WITH MEGALUG AT EACH JOINT. ALL DUCTILE IRON PIPE AND FITTINGS SHALL BE COATED PER SPECIAL PROVISIONS. ALL PVC FITTINGS SHALL BE RATED FOR 200 PSI.

WYE IN VERTICAL PLANE, ROTATED SLIGHTLY TO HORIZONTALLY SEPARATE FORCE MAIN FROM FLUSH DRAIN LINE

FOR NON-PAVED AREAS PROVIDE CONCRETE COLLARS AS SHOWN #4 HOOP, 36" DIA.

IN PAVED AREAS, MATCH EXISTING OR PROPOSED PAVEMENT STRUCTURE PER PLANS

FINISHED GRADE

TRACING WIRE (ONLY READ IF FIM IS NOT IN SAME TRENCH AS GRAVITY SANITARY SEWER LINE)

FLUSH DRAIN VALVE

FOR NON-PAVED AREAS PROVIDE CONCRETE COLLARS AS SHOWN #4 HOOP, 36" DIA.

RING & COVER CASTINGS 400B FROST PROOF

IN PAVED AREAS, MATCH EXISTING OR PROPOSED PAVEMENT STRUCTURE PER PLANS

FINISHED GRADE

SEE FORCE MAIN CLEANOUT ON THIS SHEET FOR DETAILS ON THIS.

SEE FORCE MAIN CLEANOUT ON THIS SHEET FOR DETAILS ON THIS.

SECTION A-A

WET WELL CHAMBER LID

BOOT

PIPE BRACKET WITH SPACER

LONG SWEEP 90°

PER PLANS \* INVERT

DRAIN

WET WELL ENTRANCE TUBE WALL

WET WELL

LOCATION OF GRAVITY SEWER WHEN IN THE SAME TRENCH

WYE

WET WELL CHAMBER LID

BE OFFSET 2.0' FROM WET WELL SHALL WELL & FORCE MAIN

DRAIN LINE TO WET WELL

CLEANOUT RISER

45° BEND

FINISHED GRADE

TRACING WIRE (ONLY READ IF FIM IS NOT IN SAME TRENCH AS GRAVITY SANITARY SEWER LINE)

FLUSH DRAIN VALVE

FOR NON-PAVED AREAS PROVIDE CONCRETE COLLARS AS SHOWN #4 HOOP, 36" DIA.

RING & COVER CASTINGS 400B FROST PROOF

IN PAVED AREAS, MATCH EXISTING OR PROPOSED PAVEMENT STRUCTURE PER PLANS

FINISHED GRADE

SEE FORCE MAIN CLEANOUT ON THIS SHEET FOR DETAILS ON THIS.

SEE FORCE MAIN CLEANOUT ON THIS SHEET FOR DETAILS ON THIS.

PLAN VIEW

WET WELL CHAMBER LID

BOOT

PIPE BRACKET WITH SPACER

LONG SWEEP 90°

PER PLANS \* INVERT

DRAIN

WET WELL ENTRANCE TUBE WALL

WET WELL

LOCATION OF GRAVITY SEWER WHEN IN THE SAME TRENCH

WYE

WET WELL CHAMBER LID

BE OFFSET 2.0' FROM WET WELL SHALL WELL & FORCE MAIN

DRAIN LINE TO WET WELL

CLEANOUT RISER

45° BEND

FINISHED GRADE

TRACING WIRE (ONLY READ IF FIM IS NOT IN SAME TRENCH AS GRAVITY SANITARY SEWER LINE)

FLUSH DRAIN VALVE

FOR NON-PAVED AREAS PROVIDE CONCRETE COLLARS AS SHOWN #4 HOOP, 36" DIA.

RING & COVER CASTINGS 400B FROST PROOF

IN PAVED AREAS, MATCH EXISTING OR PROPOSED PAVEMENT STRUCTURE PER PLANS

FINISHED GRADE

SEE FORCE MAIN CLEANOUT ON THIS SHEET FOR DETAILS ON THIS.

SEE FORCE MAIN CLEANOUT ON THIS SHEET FOR DETAILS ON THIS.

SECTION VIEW

FORCE MAIN, DRAIN & CLEANOUT (SHADED PIPELINE)  
CLASS 52 D.I.P. WITH FLANGE FITTINGS PER LIFT STATION DETAILS, AND COATED PER SPECIAL PROVISIONS.

DR 14 CLASS 200 C900 PVC OR CLASS 52 D.I.P. WITH M&M J FITTINGS WITH MEGALUG AT EACH JOINT. ALL DUCTILE IRON PIPE AND FITTINGS SHALL BE COATED PER SPECIAL PROVISIONS. ALL PVC FITTINGS SHALL BE RATED FOR 200 PSI.

WYE IN VERTICAL PLANE, ROTATED SLIGHTLY TO HORIZONTALLY SEPARATE FORCE MAIN FROM FLUSH DRAIN LINE

FOR NON-PAVED AREAS PROVIDE CONCRETE COLLARS AS SHOWN #4 HOOP, 36" DIA.

IN PAVED AREAS, MATCH EXISTING OR PROPOSED PAVEMENT STRUCTURE PER PLANS

FINISHED GRADE

TRACING WIRE (ONLY READ IF FIM IS NOT IN SAME TRENCH AS GRAVITY SANITARY SEWER LINE)

FLUSH DRAIN VALVE

FOR NON-PAVED AREAS PROVIDE CONCRETE COLLARS AS SHOWN #4 HOOP, 36" DIA.

RING & COVER CASTINGS 400B FROST PROOF

IN PAVED AREAS, MATCH EXISTING OR PROPOSED PAVEMENT STRUCTURE PER PLANS

FINISHED GRADE

SEE FORCE MAIN CLEANOUT ON THIS SHEET FOR DETAILS ON THIS.

SEE FORCE MAIN CLEANOUT ON THIS SHEET FOR DETAILS ON THIS.

SECTION A-A

WET WELL CHAMBER LID

BOOT

PIPE BRACKET WITH SPACER

LONG SWEEP 90°

PER PLANS \* INVERT

DRAIN

WET WELL ENTRANCE TUBE WALL

WET WELL

LOCATION OF GRAVITY SEWER WHEN IN THE SAME TRENCH

WYE

WET WELL CHAMBER LID

BE OFFSET 2.0' FROM WET WELL SHALL WELL & FORCE MAIN

DRAIN LINE TO WET WELL

CLEANOUT RISER

45° BEND

FINISHED GRADE

TRACING WIRE (ONLY READ IF FIM IS NOT IN SAME TRENCH AS GRAVITY SANITARY SEWER LINE)

FLUSH DRAIN VALVE

FOR NON-PAVED AREAS PROVIDE CONCRETE COLLARS AS SHOWN #4 HOOP, 36" DIA.

RING & COVER CASTINGS 400B FROST PROOF

IN PAVED AREAS, MATCH EXISTING OR PROPOSED PAVEMENT STRUCTURE PER PLANS

FINISHED GRADE

SEE FORCE MAIN CLEANOUT ON THIS SHEET FOR DETAILS ON THIS.

SEE FORCE MAIN CLEANOUT ON THIS SHEET FOR DETAILS ON THIS.

PLAN VIEW

WET WELL CHAMBER LID

BOOT

PIPE BRACKET WITH SPACER

LONG SWEEP 90°

PER PLANS \* INVERT

DRAIN

WET WELL ENTRANCE TUBE WALL

WET WELL

LOCATION OF GRAVITY SEWER WHEN IN THE SAME TRENCH

WYE

WET WELL CHAMBER LID

BE OFFSET 2.0' FROM WET WELL SHALL WELL & FORCE MAIN

DRAIN LINE TO WET WELL

CLEANOUT RISER

45° BEND

FINISHED GRADE

TRACING WIRE (ONLY READ IF FIM IS NOT IN SAME TRENCH AS GRAVITY SANITARY SEWER LINE)

FLUSH DRAIN VALVE

FOR NON-PAVED AREAS PROVIDE CONCRETE COLLARS AS SHOWN #4 HOOP, 36" DIA.

RING & COVER CASTINGS 400B FROST PROOF

IN PAVED AREAS, MATCH EXISTING OR PROPOSED PAVEMENT STRUCTURE PER PLANS

FINISHED GRADE

SEE FORCE MAIN CLEANOUT ON THIS SHEET FOR DETAILS ON THIS.

SEE FORCE MAIN CLEANOUT ON THIS SHEET FOR DETAILS ON THIS.

SECTION A

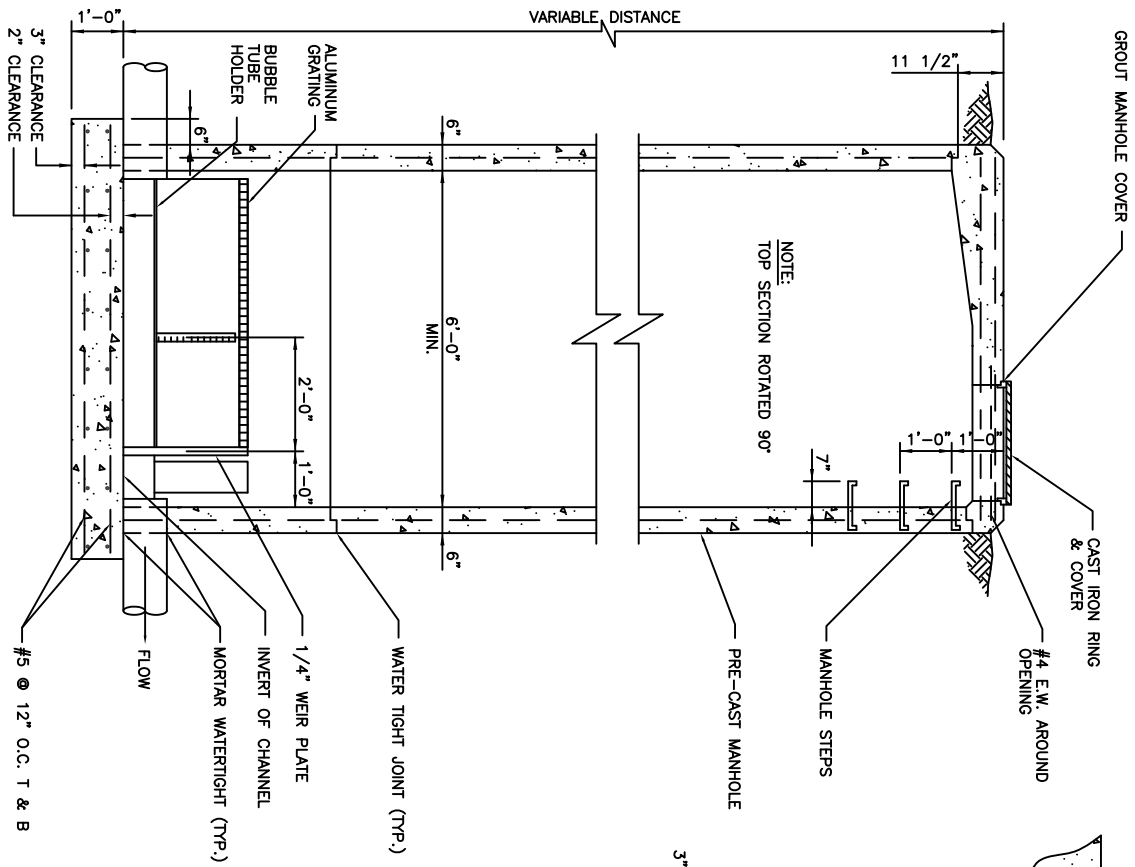

DETAIL 1

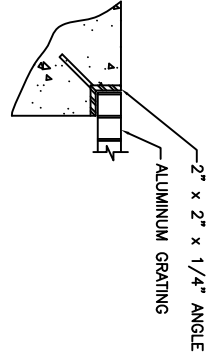

DETAIL 2

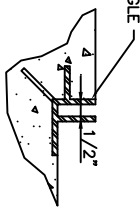

PLAN VIEW

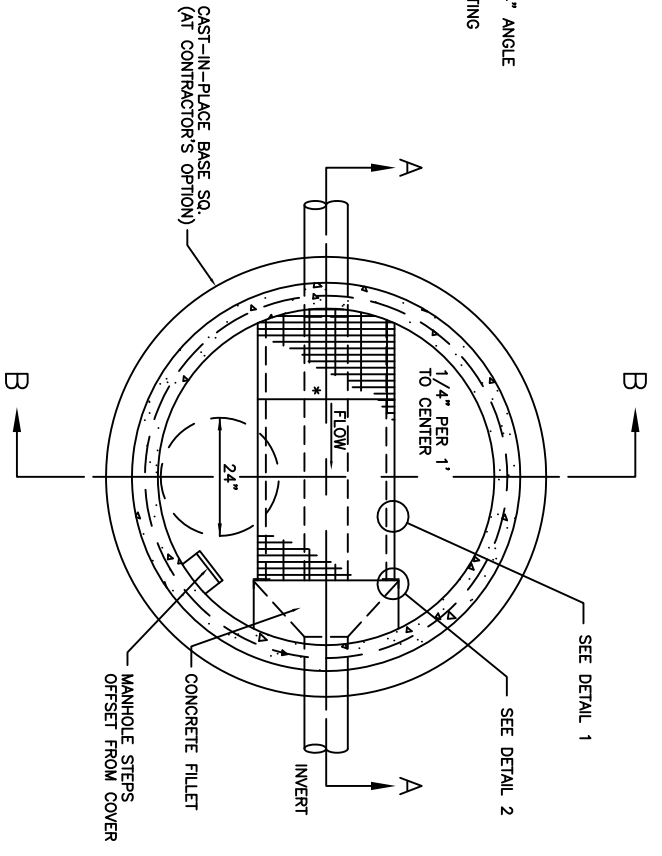

SECTION B

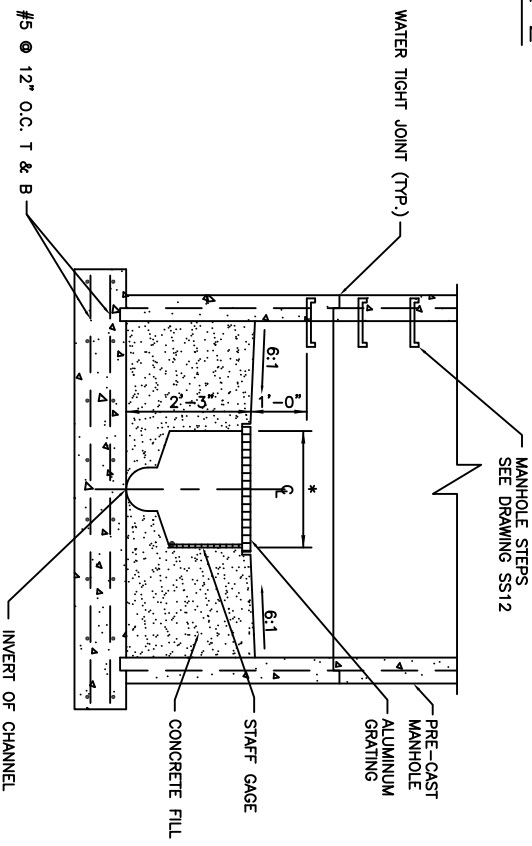

\* VARIES WITH FLOW

## Chapter 4

### STREET SYSTEM STANDARDS

#### Sections.

- 4.1: **General Provisions**
- 4.2: **Street System Design Criteria, Quality Control and Quality Assurance**
- 4.3: **Removals, Excavation, Backfilling and Restoration Specifications**
- 4.4: **Base Course Construction**
- 4.5: **Hot Mix Asphalt Pavement Materials and Construction**
- 4.6: **Final Inspection and Acceptance**
- 4.7: **Street Details**

#### 4.1: **General Provisions.**

- (A) **Legislative Authority.** The City Council is authorized to regulate vehicular access to and from any public street within the City in order to protect the public health, safety and welfare, to maintain efficient traffic flow, to maintain proper right-of-way drainage and to protect the functional levels of public streets. The City Council is also authorized to prohibit anyone from causing or permitting a street to become obstructed or damaged in any way, or permitting water, wastewater, or other substance from any ditch, lateral, canal, reservoir, rain or flume or other artificial water course to flow across such a street.
- (B) **Traffic Control Devices and Pavement Markings.** All traffic control devices and pavement markings installed on City streets shall conform to the most recent edition of the *Manual on Uniform Traffic Control Devices (MUTCD)*, and any manual or supplement thereto, approved and distributed by the City of Fruita. Said manuals are available for review at the City Engineer's office. An applicant for a permit under this Title may be required to conduct any accident studies, traffic impact analysis, traffic control studies or any other engineering studies required by State law, this Title, or by the MUTCD which are a prerequisite for the installation of traffic control devices on City streets. All streets classified as collector or higher designations shall receive as a minimum, appropriate yellow centerline pavement markings, a white stop bar and white edge lines on either side when curb and gutter are not present.

(C) **Permits Required.** An excavation and right-of-way permit, issued by the City of Fruita Public Works Department, is required for all work within a City right-of-way where use of the right-of-way is needed for construction vehicles, staging of materials, or safety barricades. For the purposes of this Section, “work” is defined as any utility installation or repair, any modification or repair to pavement, curb, gutter, or sidewalk required to provide access to a property, or any alteration of the ground surface within or adjacent to the public right-of-way for the purpose of installing any improvement which will affect drainage patterns or sight distances. The requirements of this Section apply to all projects or construction, and to all individuals and entities, including utility companies that may hold a franchise from the City, except as listed in subsection (4) below. A Performance bond or other security approved by the City Attorney may be required by the Public Works Department to ensure conformance with permit provisions. Engineered plans prepared by a Colorado registered professional engineer may also be required. The Public Works Department or City Engineer shall in accordance with plans, specifications and details approve construction. Approved permits shall not be changed without written consent of the Public Works Director or City Engineer.

- (1) Permit applications are available from the City of Fruita Public Works Department.
- (2) Permit applications shall include a traffic control plan unless the Public Works Department Director specifically waives this provision.
- (3) Permit applications shall be submitted a minimum of three (3) working days prior to beginning work, except in emergency situations.
- (4) Exceptions. The following work and/or projects are exempted from the permit requirements of the Chapter.
  - (a) Work performed internal to a Development or a commercial site approved by the City and subject to the development requirements of Title 17 (Land Use Code); and
  - (b) Work performed in or adjacent to a County, State, or Federal right-of-way shall obtain applicable permits from the appropriate governing agency.

(D) **Street Maintenance Notice.** The City shall not be responsible for the maintenance of streets in new subdivisions and developments until the street improvements are approved and accepted by the City.

(E) **Enforcement.** It is the responsibility of the City of Fruita Police Department to enforce applicable provisions of Colorado and City traffic laws on the City of Fruita street system. Insofar as possible, the Police Department will cooperate with the Public Works Department and other officials of the City of Fruita in administering the provisions contained herein and in developing ways and means to

improve traffic conditions. Work being performed within a City right-of-way without the proper permits shall cease immediately upon the direction of the City Engineer, Public Works Director, or their designated representative. In cases of noncompliance with permit requirements or unauthorized obstruction or use of a City street or right-of-way, the city may seek additional remedies, including fees, damages, injunctive relief, and may file criminal complaints against the person or persons responsible or participating in the violation.

#### **4.2: Street System Design Criteria.**

These Engineering Design Criteria and Construction Specifications represent minimum requirements and design values. Additional requirements of higher design values, commensurate with conditions, may be required by the City, if in their judgment, they are in the best interest of the City. These specifications have been prepared to assist Engineers preparing plans for roads and other street related public improvement projects in the City of Fruita. Variations may be permitted based solely on sound engineering practice and will be reviewed and approved by the City Engineer's Office on an individual basis. Such variations must be requested in writing along with sufficient documentation supporting the request.

CDOT Specifications are referenced in this document. Section 101 and Sections 200 through 717 of the Standard Specifications for Road and Bridge Construction, Colorado Department of Transportation, State of Colorado, (*CDOT Specifications*) as re-emphasized, supplemented or amended by the State shall govern all road and bridge construction work within any public right-of-way owned and maintained by the State.

Layout of all street systems shall conform to the City subdivision requirements as defined in the Land Use Code. The City of Fruita Land Use Code references the Mesa County Road and Bridge Standard Construction Specifications, which is considered a primary design guide for City streets. However, differences between the Mesa County Specifications and this Specification do exist, and in the case of conflict, this Specification controls. Generally, Local residential street cross sections shall be used in areas where average daily traffic (ADT) is not likely to exceed one thousand (1000) vehicles per day. Minor Collector street cross sections shall be used in areas where ADT ranges between 1000 and 3000 ADT. On-street parking will be allowed only where left turn lane is not required. Collector street cross sections will generally be used in all commercially zoned areas. Traffic volumes will range between 0-3000 ADT. On-street parking is not allowed. Industrial street cross-sections will generally be used in industrial zoned areas. Traffic volumes will range between 0-3000 ATD. On-street parking is not allowed. Streets in industrial areas may be constructed with 5-foot wide longitudinal "V" pans in lieu of vertical curb and gutter where approved by the City Engineer. Additional ROW and/or easements may be required to satisfy other criteria contained in these Engineering Design Criteria, or as deemed necessary by the City Engineer. Areas outside the ROW shall be contour graded, compacted, and sloped, as required for proper drainage, soil



stability, and maintenance accessibility. Cuts and fills proposed on slopes greater than three (3) horizontal to one (1) vertical shall require supporting calculations done by a qualified Soils Engineer on a soils analysis.

Requests for subdivision, zoning and other site developments may require a Traffic Impact Study. This study shall use the Institute of Traffic Engineers (I.T.E.) informational manual, in a form specified by the City Engineer. A summary of City Street and Driveway Standards is shown in section 4.7.

Alternate Local street cross sections will be considered from those standards shown in the Mesa County Road and Bridge Standards. The minimum lane width standards are displayed in Section 4.7, Street and Driveway Standards.

(A) **Private Street Construction.** Construction of a private street within the City is subject to the same process and procedures for a public street except for the following:

(1) A registered professional engineer shall certify that the proposed street improvements are constructed within the legally documented access, conform to City approved plans and are constructed in accordance with applicable specifications.

(2) The City will make no acceptance for maintenance, but the street shall pass a final inspection by a City inspector in order to release any improvements guarantee and/or permit the issuance of planning clearances for building permits.

(3) Private streets serving subdivisions and other developments (commercial, etc.) shall be clearly noted on as-built drawings as “private street – not City maintained” on the plat of the subdivision; on the Composite Site Plan; and on other developments plans.

(B) **Planning Principles for Local Circulation Systems.** Basic considerations in the design of local circulation systems shall recognize the following factors: (1) safety for both vehicular and pedestrian traffic; (2) efficiency of service for all users; (3) liability especially as affected by traffic elements in the circulation system; and (4) economy of both construction and the use of land. Design of streets should minimize maintenance costs. Each of the following principles is an elaboration on one or more of these four factors. The principles are not intended as absolute criteria, since instances may appear where certain principles conflict. The principles should, therefore, be used as guides to proper systems layout.

(1) **Insure Vehicular and Pedestrian Access and Provide Utility Access.** The primary function of local streets is to serve abutting properties. Street widths, placement of sidewalks, patterns of streets and the number of intersections are related to safe and efficient access to abutting lands.

(2) **Control Access to Arterials.** Local circulation systems and land development patterns should not detract from the efficiency of peripheral arterial streets. Ideally, land development should occur so that no parcels require direct access to arterial routes. The number of access points between the local circulation system and the arterial system should be minimized. Intersections along arterial routes should be properly spaced for efficient signalization and traffic flow. The streets that do intersect with the arterial system will tend to have a high volume since they are the only exit points. The number of residential lots that have direct access onto these streets should therefore also be minimized.

(3) **Discourage Speeding.** Residential streets should be designed to discourage fast movement of vehicular traffic (more than 25 m.p.h.) and incorporate traffic calming measures where appropriate.

(4) **Interconnectivity.** All developments should be planned to provide both vehicle and pedestrian/bicycle connectivity to adjacent undeveloped properties and to the existing circulation system. Whenever possible, street stubs to adjacent parcels, and pedestrian/bicycle paths shall be incorporated into the design of the development.

(5) **Parking.** Parking requirements are found in Chapter 17.39 of the City of Fruita Land Use Code.

(C) **Minimum Requirements for Local Circulation Systems.** In addition to the planning principles outlined in Section 4.2 (B), the minimum requirements of this Section shall apply to the design of new streets. Additional specific requirements can also be found in the Mesa County Standard Specification of Road and Bridge Construction. Where conflicts exist between this Section and provisions of the Mesa County Standard Specification for Road and Bridge Construction, the provisions of this Section shall apply.

(1) **Development Access.** Any development exceeding two hundred fifty (250) average daily traffic (ADT) or twenty-five (25) dwelling units shall have a minimum of two (2) fully platted ingress/egress points (dedicated right-of-way), or one (1) fully platted ingress/egress point plus a secondary access point for emergency vehicles. Any development exceeding three hundred fifty (350) ADT or 35 dwelling units shall have a minimum of two (2) fully platted ingress/egress points. Any development exceeding seven hundred fifty (750) ADT or seventy-five (75) dwelling units shall have a minimum of three (3) fully platted ingress/egress points.

(2) **Phased Developments.** For phased developments, secondary access shall be installed at or prior to the time at which the total number of units served by a single access exceeds twenty-five (25) units.

(3) **Courts and Cul-de-sacs.** A cul-de-sac shall not exceed two hundred fifty (250) ADT and in no case should its length exceed six hundred (600) feet, unless a

secondary emergency access is provided, in which case the cul-de-sac length may be increased to one thousand (1,000) feet. Dead end streets or cul-de-sacs without bulbs shall not be permitted. Streets provided or designed for future connection to adjacent areas and which provide access to structures, shall have dedicated cul-de-sacs or other turn-around design, such as a hammer head. These turn-arounds shall meet the approval of the Lower Valley Fire Protection District. The cul-de-sac bulbs or other turn-around features, if temporary, may be authorized by easement rather than dedication.

(4) **Street Stubs.** Proposed street stubs to adjacent undeveloped property may be considered in meeting the requirements of subsections (B) and (C) of this Section. The City Council shall have sole discretion to make this determination based on a consideration of current information pertaining to the potential and timing of the development of adjacent parcels.

(5) **Alleys.** Alleys provide access to the side or rear of individual land parcels. They are characterized by a narrow right-of-way width of typically 20 feet, and range in width from 16 feet in residential areas up to 20 feet in commercial areas. Industrial areas may require additional right-of-way and traveled way widths.

Alleys should be aligned parallel to the street property lines. It is desirable to situate alleys in such a manner that both ends of the alley are connected either to streets or to other alleys. Where two alleys intersect, a triangular corner cutoff of 6 feet along each property line should be provided; or an alternative 20 foot radius may be used. Dead-end alleys should be the exception. However, if there is no other acceptable alternative, a turn-around must be provided at the closed end.

Curb return radii at street intersections may range from 5 feet in residentially zoned areas to 10 feet in commercial and industrial areas. Larger radii may be required if large numbers of trucks with larger turning radii utilize the alleys. Alley grades should be established to meet as close as possible the existing grades of the abutting land parcels. However, the longitudinal grade should not be less than 0.2 percent.

Alley cross sections are typically v-shaped with transverse slopes of 2 percent (1/4"/foot) to 8 percent (1"/foot) toward the center v-gutter. Runoff is thereby directed to a catch basin in the alley or to connecting street gutters.

(D) **Streets Providing Access to Private Property.** In order to qualify as access to property within the City, a street or drive shall be one (1) of the following:

(1) **Public Maintained Street.** The City, the Colorado Department of Transportation (C.D.O.T.) or other public agencies maintain A STREET. All new driveways or other access points to a public street shall be constructed in accordance with a planning clearance issued by the Community Development Department.

(2) **Private Streets.** Private street standards are the same as public street standards. Private streets are not maintained by a public agency. The private street shall be owned by the homeowners association or other private entity that will take responsibility for maintenance.

(3) **Shared Driveways for Single Family or Duplex:**

- a. A shared driveway with less than 20 feet ROW width will be allowed with a maximum of two (2) dwelling units served by the same driveway. The pavement width will be determined on an individual basis.
- b. A shared driveway with a ROW width between 20 to 26 feet will be allowed for a maximum density of four (4) dwelling units served by the driveway. Maintenance will be equally shared by all owners served by the driveway. Pavement width shall be at least 18 feet.
- c. Access to more than four (4) dwelling units will not be permitted with a shared driveway. Access for such a density will be provided by with a private street or a public street. The standards for each are shown in section 4.7, Street and Driveway Standards.
- d. No parking is allowed on shared driveways.

(4) **Shared Driveways for Multi-Family and Non-Residential:**

- a. A shared driveway for multi-family and non-residential properties shall be determined through a site design review.

(5) **Access Requirements.** The access requirements for private streets and shared driveways are:

- a. All building lots using the private street or shared drive for access shall have the legal right for access over and across the private street or shared driveway; and
- b. Garages and other parking facilities accessing shared driveways and private streets shall be located on the lot in such a manner that movement into or out of the garage or parking area will not encroach on adjacent private property or parking areas.

(E) **General Access and Driveway Standards.**

(1) **Purpose.** The lack of adequate access management to the City's street system and the proliferation of driveways and other access approaches can become a major

contributor to traffic accidents and a major factor contributing to the functional deterioration of City streets. As new access approaches are constructed, the traffic speed and capacity of streets decreases, while congestion and hazards to the traveling public increase. As a result, significant amounts of tax dollars can be spent to improve City streets and provide additional operational capacity and safety. The objective of these standards is to both maintain safety and preserve street capacity while at the same time allowing accessibility to adjacent land uses, in a manner consistent with the functional classification of streets.

**(2) Standards.**

(a) Access to a City street or right-of-way may be obtained as described in subsection 4.1 (C). In all areas where curb and gutter are provided, all driveways accessing single family building lots shall conform to the standard construction details published by the City, and driveway surfacing material shall be concrete or asphalt. Gravel driveways are prohibited, except as noted in Chapter 4.2 (E)(2)(c). In areas where curb and gutter are not provided, all driveways shall have a minimum surface width of eighteen feet (18') at the edge of pavement, or drive surface, and taper to a minimum surface width of twelve feet (12') at a distance of six feet (6') from the edge of the drive, and maintain this surface width to the edge of the City street or right-of-way. Driveway surfacing material within the right-of-way shall be constructed with the following section dimensions:

(b) All driveways accessing non-residential lots shall be concrete or asphalt surfacing material. The minimum driveway width will be 24 ft. The minimum curb radius shall be 50 feet. This curb radius may be reduced to accommodate pedestrians in areas where higher pedestrian traffic volumes are expected.

**DRIVEWAY MATERIAL**

**MINIMUM SECTION DEPTHS**

Concrete

6 inches with 6 inches aggregate base  
Compacted to 95% T – 180

HMA

2 inches with 6 inches Class 6 aggregate

(c) In the Rural Estate (RE) and Agricultural Rural (AR) Zone Districts only, driveway surfacing material outside of the public right-of-way may be six inches (6") Class 6 aggregate base course, or other material such as recycled asphalt, so long as the surfacing material is treated to maintain a dust free condition.

(d) The maximum total width of driveway(s) serving any one (1) residential parcel shall be limited to thirty-two feet (32'), provided, that the on-street

parking requirements of subsection 17.39, City Land Use Code are fully satisfied.

- (e) Driveway grades may not exceed ten percent (10%) and adequate drainage shall be provided. A paved surface with a minimum of twelve feet (12') in width shall be available to fire, ambulance and police vehicles to within one hundred feet (100') of the principal entrance to all structures. The grade of the entrance and exit shall slope downward and away from the street surface at the same rate as the normal cross slope and for a distance equal to the width of the shoulder, but in no case less than ten feet (10') from the pavement edge.
- (f) All driveways and approaches shall be constructed so that they do not interfere with the drainage system of the public street or highway. The applicant will be required to provide, at their own expense, drainage structures at entrances and exits which will become an integral part of the existing drainage system. The dimensions of all drainage structures shall be approved by the Public Works Department prior to installation.
- (g) The horizontal axis of an approach to the street shall normally be perpendicular to the centerline of the street and extend a minimum of 40 feet beyond the travel way. An angle between 90 and 75 degrees shall be acceptable only if physical constraints require a skew angle less than 90 degrees. Driveway alignment, placement and width shall be constructed to avoid utility pedestals and other utility structures.
- (h) No more than one (1) driveway shall be allowed to any parcel of land having a platted area of one (1) acre or less. Additional access approaches to parcels having a platted area of greater than one (1) acre shall be subject to all of the provisions of Chapter 17.07 of the Fruita Municipal Code and this publication.
- (i) A driveway that has a gate across it shall be designed so that the longest vehicle using it can completely clear the traveled way of the public street when the gate is closed.
- (j) A parcel fronting on two (2) public streets with identical functional classifications shall take access from the street with the lowest twenty (20) year projected traffic volume. Residential lots fronting on two local roads do not necessarily have to take access from the street with the lowest twenty (20) year projected traffic volume.
- (k) The flow line will be determined according to classification and improvement standards for that particular classification, not the existing condition.

**(F) Access Control Standards for Arterial Streets.**

**(1) Private Direct Access.** Private direct access to arterials is discouraged. Private direct access to such arterial streets shall be permitted only when the property in question has no other reasonable access to the city's street system. When direct access is necessary, the following shall be required:

- (a) Access shall continue until such time that some other reasonable access to a lower functionally category street is available and permitted. Access permits issued by the city or by the Colorado Department of Transportation shall specify the future reasonable access location and, if known, the date the change will be made. This provision shall not be construed as guaranteeing a public street access. Subdivisions of land shall make provisions for all parcels or lots in the area to have access to a lower functional classification street in the future. Back-out driveways shall not be allowed.
- (b) No more than one (1) access approach shall be provided to an individual parcel or to contiguous parcels or lots under the same ownership unless it can be shown that additional accesses would be significantly beneficial to the safety and operation of the street or the local circulation system. Subdivision of a parcel or lot shall not result in additional access unless shown as necessary for safety or operational reasons.
- (c) On two-lane arterials, access approaches may be limited to right turns only if the approach is within five hundred (500) feet, measured near curb line to near curb line, from the nearest signalized intersection. Under no circumstances may a driveway be closer than one hundred (100) feet to the curb line of the intersecting street when measured from the driveway edge nearest the intersecting street.
- (d) Access approaches on multi-lane divided roads shall be limited to right turns only unless either: (1) the approach does not have the potential for signalization; or (2) it can be shown that allowing left turns would significantly reduce congestion and safety problems at a nearby intersection; or (3) there are no intersections, existing or planned, which allow a U-turn, and left turns can be safely designed without signalization; or (4) a painted median is present which allows continuous turning storage.

**(2) Spacing and Signalization Shall be Considered.** In areas where higher traffic volumes are present or growth is expected in the foreseeable future that will require signalization, it is imperative that the location of all public approaches be planned carefully to ensure good signal progression. An approved traffic engineering analysis shall be made to properly locate all proposed connecting access approaches that may require signalization.

**(G) Access Control Standards for Collector Streets.**

(1) **General.** Private direct access to collector streets and arterial streets shall be permitted only when the property in question has no other reasonable access to the City's street system. No more than one (1) access approach shall be provided to an individual parcel or to contiguous parcels under the same ownership unless it can be shown that additional access approaches would not be detrimental to the safety and operation of the public street, and are necessary for the safety and efficient use of the property. Back-out driveways are not allowed. Under no circumstances may a driveway be closer than one hundred feet (100') to the flow line or edge of the traveled way of the intersecting street. In urban areas, subdivision of a parcel shall not result in additional access unless shown as necessary for safety or operational reasons. Shared driveways are encouraged on all collector or higher classification of roads to minimize access points.

(2) **Spacing of Intersecting Streets.** Spacing of major intersecting streets should be at one quarter (1/4) mile intervals plus or minus two hundred feet (200'). Spacing of other public and private streets where intersection channelization improvements are not required shall be at intervals no less than three hundred feet (300'), providing that reasonable access cannot be obtained from lower classification streets.

(3) **Separation of Driveways.** Individual driveways shall have a minimum edge to edge separation distance of one hundred feet (100'). Where the lot dimensions or the location of existing driveways prevent one hundred feet (100') separation, the minimum separation distance shall be the maximum achievable, as determined by the City on a case by case basis.

(4) **Spacing and Signalization shall be Considered.** In urban or developing areas where higher traffic volumes are present or growth is expected in the foreseeable future that will require signalization, it is imperative that the location of all public approaches be planned carefully to ensure good signal progression. An approved traffic engineering analysis shall be made to properly locate all proposed connecting access approaches that may require signalization.

**(H) Access Control Standards for Local Streets.**

(1) **Private Direct Access.** Driveways located near an intersection of two (2) residential streets shall be constructed so that the driveway edge nearest the intersection is no less than fifty feet (50') from the flow line of the intersecting street. Where the intersecting street is classified as a collector or arterial, setbacks for residential driveways shall be no less than eighty feet (80') from the flow line of the intersecting street. All driveways are subject to the sight distance requirements of Section 4.2 (I) (4).



(2) **Spacing of Intersecting Streets.** Intersecting public and private streets shall be located opposing where possible or be offset by a minimum of one hundred fifty feet (150') when measured from near curb line to near curb line.

(3) **Separation of Driveways.** Individual driveways shall have a minimum edge to edge separation distance of ten feet (10'). Driveways cannot be located closer than five (5) feet to any side property line.

**(I) Intersection Requirements.**

(1) **General.** Most streets intersect at grade. To minimize potential conflicts and to provide adequately for the anticipated crossing and turning vehicle movements, geometric design of the intersection at grade shall be given careful consideration.

(2) **Locations.** Intersections occurring on horizontal or crest vertical curves are undesirable from the standpoint of sight distance and the application of super elevation. When there is latitude in the selection of intersection locations, vertical or horizontal curvature should be avoided. A line or grade change is frequently warranted when major intersections are involved.

**(3) Intersection or Access Approach Radii.**

(a) No access approach shall have an equivalent turning radius of less than twenty feet (20').

(b) A minimum fifty feet (50') equivalent turning radii shall be used for driveways when multi-unit vehicles, or single unit vehicles exceeding a thirty foot (30') wheel base, are intended to be used on a daily basis.

(c) The access approach equivalent turning radii shall not be less than that necessary to accommodate the turning radius of the largest vehicle for which the access approach is intended to be used on a daily basis.

(d) If the frequency of multi-unit vehicles, or single unit vehicles over a thirty foot (30') wheel base, is such that two (2) of these vehicles, one (1) entering and one (1) exiting, use the access at the same time, the radii shall be adequate to accommodate both vehicles with no turning conflicts.

(e) General guidelines for required curb or pavement radii are found in the City of Fruita Standard Drawings at the end of this Section.

**(4) Sight Distance Requirements.**

(a) **Public Street Intersections.** At any intersection of two (2) public streets, a sight distance triangle must provide for an unobstructed view across the

triangle formed by joining points measured along the property line from the property corner. Within the area of the triangle, there must be no sight obscuring or partially obscuring wall, fence, sign, foliage or berming higher than thirty inches (30") above the flow-line or, in the case of trees, foliage lower than nine feet (9'). Vertical measurements must be made from the flow-lines of the two (2) streets forming the triangle, or if no gutter exists, from the edge of the nearest traveled way. Objects that may be located in the triangular area are items such as fire hydrants, utility poles, utility junction boxes, and traffic control boxes, and traffic control devices. These must be located to minimize visual obstruction. The sight distance triangle dimension varies with the street classification. Refer to Diagram 4.7I at the end of this section.

The above requirements also apply to intersections of public streets and a railroad right-of-way at a railroad crossing not controlled by gates or flashing lights.

In addition to the above requirements, at any intersection of two (2) public streets, an unobstructed view as defined above must be provided across the area formed by the flow-line or edge of pavement of the intersecting street and lines, connecting them at fifteen feet (15') from their point of intersection. This area will be used to ensure that drivers of vehicles exiting from the stopped approach have available the minimum sight distance as provided in subsection 4.2(H)(4)(c).

- (b) **Private Accesses to Public Streets.** In addition to the above requirements, at any intersection of a driveway access and a public street, an unobstructed view must be provided across the area formed by the flow-line or edge of the traveled way on the public street and the private access drive edge line, and lines, connecting them at ten feet (10') from their point of intersection. This area will be used to ensure that drivers of vehicles exiting from the stopped approach of an access have available the minimum sight distance.

The sight distance criteria set forth above applies to back-out drives where sight distance may be compromised by front yard landscaping, adjacent fences, or other interferences.

- (c) **Minimum Sight Distance.** Sight distances as shown in Diagram 4.7I are designed to enable vehicles to turn left, right or cross the intersecting street without causing approaching vehicles to reduce speed by more than ten miles per hour (10 mph).

- (1) The distance requirements use a three and one-half feet (3.5') driver eye height and four and one-fourth feet (4.25') object height for passenger cars.

(2) The operating speed on each approach is assumed to be, in order of desirability, a) the eighty-fifth (85<sup>th</sup>) percentile speed, b) the speed limit if based on an engineering study, or c) in case of a new facility, the design speed.

**(J) Curb Cuts for Recessed Diagonal Parking**

- (1) No portion of parked car shall extend onto the sidewalk.
- (2) Flow line of the gutter to be maintained.
- (3) Rear portion of the parked car shall not extend more than 6 feet from the original curb line where parallel parking was in effect.
- (4) Not allowed on a State Highway or City Arterial Street.
- (5) Must comply with *Model Traffic Code* for Colorado Municipalities, as adopted by the City, which includes the following:
  - (a) No parking within 5 feet of public or private driveway.
  - (b) No parking within 15 feet of a fire hydrant.
  - (c) No parking within 20 feet of a crosswalk at an intersection.
  - (d) No parking within 30 feet of flashing beacon, stop sign, yield sign or traffic control signal.
  - (e) No parking within 50 feet of railroad crossing.
- (6) Design, location, and construction are subject to the approval of the City Engineer.
- (7) No construction or design expense shall be borne by the City.
- (8) It will be understood that completed parking area is for use of the general public and not solely for the private use of the person requesting it.

**(K) Geotechnical Investigation and Pavement Design Report.** This report shall be prepared by or under the supervision of and signed by an Engineer and shall include the following information.

- (1) Vicinity map to locate the investigated area.
- (2) Scaled drawings showing the location of soil borings.

- (3) Scaled drawings showing the estimated extent of sub-grade soil types and ESAL for each street.
- (4) Pavement design alternatives for each street on a scaled drawing.
- (5) Tabular listing of sample designation, sample depth, Group Number, Liquid Limit, Plasticity Index, percent passing the No. 200 sieve, Group Index, Unified and AASHTO Classification, and soil description.
- (6) Proctor Compaction Curves.
- (7) R-value test results of each soil type used in the design.
- (8) Pavement design nomographs (per AASHTO Guide for Design of Pavement Structures, 1993) to show Soil Support – ESAL – SN.
- (9) Design calculations.
- (10) A narrative describing potential sub-grade soil problems including, but not limited to, heave or settlement prone soils, frost susceptible soils, ground water, drainage considerations (surface and subsurface), cold weather construction (if appropriate), and other factors, properties, or fill areas which could affect the design or performance of the pavement system.
- (11) Recommendations to alleviate or mitigate the impact of problems discussed above.

**NOTE:** The pavement Design Report is generally included as a subsection of the overall Geotechnical Investigation Report required of all development. When determining the number and location of soil borings, contact the City Engineer for specific direction. A minimum of two soil borings shall be located within proposed street locations.

**(L) Quality Control and Quality Assurance.**

(1) **Quality Control.** The Contractor is responsible for quality control of all work performed and shall implement whatever procedures, methods, testing, surveying, and supervision that is required in order to that the work conforms to the approved plans and Street System Standards.

The Contractor is responsible for submission of HMA quality control testing documentation to verify that the mix design for the work performed conforms to the Standards at frequencies for **Hot Mix Asphalt (HMA)** as shown in **Table 4.1.**

(2) **Quality Assurance.** The developer, owner or entity responsible for administering the construction of public facilities shall provide a quality assurance program. This program shall include systematic inspection and testing of the work and materials during construction to assure the owner and the City that the Contractor is providing work that is in conformance with the City-approved plans and specifications.

Initial testing shall be performed at the beginning of each construction phase in order to identify and correct any non-compliant work.

A minimum of one test will be required for any portion of material less than that shown in the “Minimum Test Frequency” column on **Table 4.1** below.

All failing tests shall be re-tested after the material has been reworked, modified or adjusted by the Contractor. The Contractor will be required to remove and replace any work or materials that do not meet test requirements or specifications to the satisfaction of the City.

(3) **Field and Laboratory Testing Requirements.** All sampling and testing shall be performed using the proper equipment as required by each test procedure. Personnel performing sampling and testing of aggregates for hot mix asphalt (HMA) or bituminous mixtures shall possess the appropriate CAPA (Labcat) certification or combination of certifications including:

- A - Lay down
- B – Asphalt Plant Materials Control
- C – Mixture Volumetrics and Stability
- D – Aggregates

The HMA testing laboratory shall have a current AMRL certification.

Technicians performing testing of soils or aggregates for subgrade, road base or embankment construction shall be NICET Level II (soils) or WAQTC certified.

For concrete field testing and sampling an ACI Level I certification is required. For concrete lab curing and compressive strength testing, the laboratory shall have a current CCRL certification or the Laboratory Supervisor also shall have a current ACI Laboratory I certification.

**TABLE 4.1  
REQUIRED *QUALITY ASSURANCE (QA) /QUALITY CONTROL (QC) TESTING*  
CITY OF FRUITA, COLORADO**

TEST REQUIRED	TEST PROCEDURE TOLERANCE	MINIMUM TEST FREQUENCY
<b>SOILS</b>		
Compaction of subgrade under curbs, gutters and sidewalks. **	AASHTO T99, T310 95% minimum	1 per 200 LF
Compaction of subgrade and embankment under roadways. **	AASHTO T99k T310 95% minimum	1 per 400 SY 1 per fillet; 1 per drainage pan
Compaction of aggregate base course and/or sidewalks.	AASHTO T180, T310 95% minimum	1 per 200 LF under concrete curbs, gutters
Compaction aggregate base course under fillets and drainage pans.	AASHTO T180, T310 95% minimum	1 per fillet; 1 per drainage pan
Compaction of aggregate base course materials under roadways. Compaction of Structure Backfill.	AASHTO T180, T310 95% minimum AASHTO T180, T310 95% minimum	1 per 400 SY 1 for each 2 ft. of vertical depth per 100 LF of structure perimeter
Gradation of aggregate base course (QC)	CDOT Table 703-2	1 per 5000 Ton
<b>HMA *</b>		
Asphalt Content (QC)	CP42 method A, CP85 or CPL 5120	1 per 1000 Ton 1 per day minimum
Gradation of aggregate (QC)	CP31, CDOT Table 703-3	1 per 1000 Ton
Air Voids (Pa) (QC)	AASHTO T269, 2.8% to 5.2%	1 per 1000 Ton
Voids in Mineral Aggregate (VMA) (QC)	CP48 See Table 5	1 per 1000 Ton
Percent Relative Compaction (QC)	CP51 & 81 92% to 96%	1 per 500 SY
<b>CONCRETE TESTS *</b>		
Compressive Strength (4 cylinders per set) (QC)	AASHTO T22 & T23 CDOT Table 601-1	1 set of tests per 30 to 100 CY 1 set of tests per 100 CY for machine work 1 set of tests per 30 CY for hand work
Air Content (QC) Unit Weight	T121, T152, T196 4.5% - 7.5%	1 per 100 CY
Slump (QC)	AASHTO T119, 4" maximum	1 per 100 CY
<b>NOTES:</b> CP= Colorado Procedure (CDOT) Field Materials Manual.  * The job mix formulas for HMA and Portland Cement concrete shall be submitted in typed form by the contractor to the City when requested at least 10 days prior to the start of paving or concrete placement.  ** Subgrade and embankment soils shall be compacted in accordance with AASHTO T180 when specified in the Contract Documents or when directed or approved in writing by the Engineer. The top 6" of subgrade under all concrete shall be compacted to at least 95% of AASHTO T99 maximum density. Compaction testing for fillet and v-pan subgrade material is required.  A minimum of one test will be required for any portion of material less than that shown in the "Minimum Frequency" column, unless otherwise approved by the City inspector.  Refer to Chapter 5, Concrete Standards		

### 4.3 Removals, Excavation, Backfilling, and Restoration Specifications

**(A) General.** This section covers surface removals, excavation, backfilling, compaction, disposal of surplus material, restoration of disturbed surfaces, and all other work required for the safe and proper road construction.

**(B) Concrete Removal.** Concrete pavement shall be cut vertically along pre-marked lines, unless otherwise specified. The depth of the saw cut shall be to the full depth of the concrete section.

**(C) HMA Pavement Removal.** HMA pavement designated to be cut for removal, where new HMA pavement will be placed against the cut face, shall be wheel cut, or saw cut. HMA pavement designated for removal, where concrete pavement will be placed against the cut face, shall be saw cut along a straight line with a vertical face. Cut faces of concrete and HMA pavement shall be protected from damage until the new pavement is placed against them. Spalls on the cut line shall be re-cut to a neat line.

**(D) Excavation and Backfill of Structures.** Flow fill may be used to backfill structures under paved surfaces. It may be used to backfill utility trenches, manholes and other structures and excavations in unpaved areas. Flow fill shall not be placed around the bottom half of pipes or structures that could be displaced or damaged by the buoyant forces of the flowable fill material, unless adequate provisions are taken to prevent displacement of the pipe. Pipes shall be backfilled with an approved material to twelve inches (12") above the pipe or structure and compacted to 90% compaction modified proctor.

Flow-fill shall meet the requirements of section 5.10 of the *Concrete Standards*, unless the City approves a deviation, in writing. The City may require that a sample of the proposed flow-fill mix be prepared, tested and/or placed in the backfill to demonstrate its performance prior to approval of the mix. Flow-fill shall be placed to the depth indicated on the plans or as directed by the City. Bleed water shall be drained off or otherwise removed from the surface of the flow-fill after it has been placed.

Excavation and back fill for the installation of all pipe, manholes, valves, vaults and other structures and appurtenances shall be in accordance with these Specifications.

**(E) Topsoil Placement.** Topsoil shall consist of free draining friable sandy loam; free from roots, rocks larger than 3/8 inches, subsoil, debris, brush weeds, heavy clay, hard clods, toxic substances or other material which would be detrimental to its use on the project. Wetland topsoil material shall consist of moist, organic soil, including any existing wetland vegetation and seeds to be excavated from areas shown on the plans or as directed.

**(F) Dust Control.** The Contractor shall furnish and apply a dust palliative on portions of the roadway, haul roads and other locations as necessary or as directed to prevent air borne dust. This shall include prevention of dust generated from the Contractor's operations and construction period including nights, weekends and holidays.

**(G)Subgrade Stabilization.** Subgrade stabilization shall be used to replace wet or otherwise unstable ground conditions below the normal subgrade elevation. Subgrade stabilization shall include excavation of unsuitable material and the furnishing, placing and compaction of aggregate base course (CDOT class 2) to the depth and limits determined by the Engineer, and approved by the City. The uses of stabilization fabrics and/or Geogrid materials are acceptable with the approval of the City.

#### **4.4: Base Course Construction**

**(A) General.** Materials shall be placed on an approved subgrade, which has been proof rolled within the past twenty-four hours and found to be stable and non-yielding. Should weather conditions change, such as freezing, precipitation, etc., aggregate base materials shall not be placed until the subgrade is re-approved by the City. Proof rolling and/or new compaction tests may be required to demonstrate that subgrades have not been impacted by changed weather conditions.

- (1) The required thickness of the base course may be reduced, subject to the approval of the City, by increasing the depth of HMA at the rate of two inches (2”) of aggregate base course to one inch (1”) of HMA or appropriate depths based on strength coefficients. Minimum HMA = 3” residential streets; 4” collector streets.
- (2) If the required compacted thickness exceeds six inches (6”), the base course shall be constructed in two or more lifts of equal thickness. The maximum thickness of any lift to be compacted shall not exceed six inches (6”).
- (3) The minimum depth of base course on streets and alleys shall be six inches (6”). CDOT Class 5 and 6 materials shall be classified as base course. Class 5 and Class 6 material shall have a minimum “R” value of 70.
- (4) CDOT Class 2 material shall be classified as sub-base course and used only when the base course requirement is greater than six inches (6”). Class 2 material shall have a minimum “R” value of 60.



CDOT TABLE 703-2 CLASSIFICATION FOR AGGREGATE BASE COURSE							
Sieve Size	Mass Percent Passing Square Mesh Sieves						
	LL not greater than 35			LL not greater than 30			
	Class 1	Class 2	Class 3	Class 4	Class 5	Class 6	Class 7
100 mm (4")		100					
75 mm (3")		95-100					
60 mm (2.5")	100						
50 mm (2")	95-100			100			
37.5 mm (1.5")				90-100	100		
25 mm (1")					95-100		100
19 mm (3/4")				50-90		100	
4.75 mm (#4)	30-65			30-50	30-70	30-65	
2.36 mm (#8)						25-55	20-85
75 um (#200)	3-15	3-15	20 max	3-12	3-15	5-15	

(B) **Base Course Placement.** The base course material shall be placed on the previously prepared subgrade at the locations and in the proper quantities to conform to the typical cross sections as shown on the plans. Placing and spreading shall be done by means of a spreader machine, moving vehicle, motor grader, or by other approved equipment methods. The material shall be placed without segregation. Any segregated areas shall be removed and replaced with uniformly graded material at the Contractor's expense.

The base course material may be placed in lifts of up to six inches (6"), providing that after compaction, uniform density is obtained throughout the entire depth of the lift. If the required depth exceeds six inches (6"), it shall be placed in two (2) or more lifts of approximate equal thickness. If uniform density cannot be obtained by six inch (6") lifts, the maximum lift shall not exceed four inches (4") in final thickness.

Base course material shall not be placed on a foundation that is soft or spongy or one that is covered by ice and snow. Base course material shall not be placed on dry or dusty foundations where the existing condition would cause rapid dissipation of moisture from the base material and hinder or preclude its proper compaction. Such dry foundations shall have water applied to them and shall be reworked or re-compacted. Foundations that are soft or spongy shall be evaluated on a case by case basis as to the most appropriate measure to insure a stable foundation.

Care shall be exercised in the hauling and placing of base course so as to avoid segregation of the course and fine materials. The base course material shall be placed on the previously prepared and approved subgrade in sufficient quantity to conform to the thickness specified on the approved plan and profile. The material shall be mixed and watered to obtain a uniform mixture at optimum moisture.

- (C) **Compaction.** Rolling shall be continuous until the base material has been compacted thoroughly, generally in accordance with Section 304 of the CDOT Standard Specifications. Water shall be uniformly applied as needed during compaction to obtain optimum moisture content and to aid in consolidation. The surface of each lift shall be maintained during the compaction operations in such a manner that a uniform texture is produced and the aggregates are firmly placed.
- (D) **Optimum Moisture Content.**
- (1) Non-cohesive and cohesive materials and soils shall be placed and compacted near optimum moisture (+ or – 2%). Compaction shall be continued until the base course has a density of not less than 95 percent of its Standard or Modified Proctor near optimum moisture.
  - (2) At least twenty percent (20%) of the tests shall be taken within two feet (2') of a manhole or valve box on every two feet (2') of backfill.
  - (3) Nuclear testing equipment and methods are acceptable when preformed by an approved certified testing laboratory and when performed in accordance with the requirements of AASHTO T-238.
- (E) **Final Proof-Rolling.** The finished base course surface shall be smooth and free of ruts and irregularities, and shall be true to grade and crown as shown on the plans. The base course shall be maintained in this condition by watering, drying, rolling or blading until the surfacing is placed.

After the base course has been compacted, tested and found to meet specifications, the entire base shall be proof-rolled with a heavily loaded vehicle, witnessed by a City Engineering Department Representative. The vehicle must have a certified loaded GVW of fifty thousand pounds (50,000) with a loaded single axle weight of at least eighteen thousand pounds (18,000) and a tire pressure of ninety psi (90) (a typical full water truck or a loaded dump truck). Sub-base which is pumping or deforming must be reworked, replaced or otherwise modified to form a smooth, stable, non-yielding base for subsequent paving lifts. Provide at least forty-eight (48) hours notice for requesting a proof roll inspection before paving.

**Base Course Approval.** The results of field density tests and proof rolling shall be submitted and reviewed by the City Engineer. Provided all tests are acceptable, compaction shall be approved for the placement of the HMA or concrete. Should testing indicate unsatisfactory work, the necessary reworking, compaction or replacement shall be required prior to continuation of the paving process. The approval is valid for twenty-four (24) hours. Changes in weather, such as freezing or precipitation, shall require re-approval of the base course.

**4.5: HMA Pavement Materials and Construction.**

(A) The HMA materials design shall be consistent with that produced by local plants for CDOT use. In the absence of such a design mix, the following requirements will be met.

(B) **General.** This work consists of one or more lifts of bituminous mixture constructed on a prepared foundation in accordance with these Street Systems Standards. The placement of hot HMA shall conform to the lines, grades, thickness and typical cross sections shown on the plans or established. Each lift shall be compacted to the required density and approved before placement of the next lift.

The minimum pavement thickness for arterial and collector streets will be four (4) inches. The minimum pavement thickness for local residential streets will be three (3) inches. These thickness requirements are the minimum acceptable by the City regardless of the recommendations contained in the project geotechnical report.

HMA for patching consists of those quantities required for the placement of unstable corrugated areas in the existing pavement, pipe trenches, areas removed for curb and gutter forms, areas between the curb and gutter or sidewalk and existing paved parking lots, and areas designated on the plans.

(C) **Aggregates.** Aggregates shall be of uniform quality, clean, hard, durable particles of crushed stone, crushed gravel, natural gravel, or crushed slag free from clay balls, vegetable matter or other deleterious materials meeting the requirements in Table 4.2 below. Aggregates meeting the requirements of Table 4.2 shall be used to develop the Job Mix Formula and the HMA mixture. The aggregate should be composed of angular, coarse textured, cube shaped particles. Excess of fine material shall be wasted before crushing. Sand may be used to obtain gradation of the blended aggregate mixture but should not exceed more than 15%. If the present aggregate passing the #4 sieve is greater than 10% by weight of the individual aggregate sample, plasticity will be determined in accordance with AASHTO T 99.

<b>TABLE 4.2: AGGREGATE PROPERTIES</b>			
<b>Property</b>	<b>Test Procedure</b>	<b>Coarse Retained on #4 Sieve</b>	<b>Fine Passing the #4 Sieve*</b>
Fine Aggregate Angularity Traffic Level Low, Moderate Trails and Pathways  Traffic Level 3 to 5 Moderate, High, Parking Lots	CP-L5113		40% Minimum  45% Minimum
Fractures Faces (minimum 2)	CP – 45	80% Minimum	
LA Abrasion	AASHTO T 96	45% Minimum	
Flat and Elongated Places	AASHTO M 283	10% Maximum	
Sodium Sulfate Soundness	AASHTO T 104	12% Maximum Combined Coarse and Fine	
Adherent Coating (Dry Sieve)	ASTM D 5711	0.5%	45% Minimum
Sand Equivalent	AASHTO T 176		45% Minimum

\* Note: Plasticity Index (AASHTO T89, T90) will be non plastic.

(1) **Sources of Aggregates.** The contractor with the submittal of the job mix formula shall designate sources of aggregates.

(2) **Gradation.** The gradation of aggregates used in the mixture shall meet the criteria shown in Table 4.3, the Aggregate Master Range Table, and shall not vary from the low limit on one sieve to the high limit on the adjacent sieve, or vice versa, but shall be well graded from coarse to fine. The nominal size aggregate used in the HMA mixture shall not be more than one third (1/3) the thickness of the HMA lift being constructed.

<b>TABLE 4.3: AGGREGATE MASTER RANGE TABLE</b>			
<b>Sieve Size</b>	Percent by Weight Passing Square Mesh Sieves		
	Grading S	Grading SG	Grading SX
1 1/2"		100	
1"	100	90 – 100	
3/4"	90 – 100		100
1/2"			90 – 100
3/8"			
#4			
#8	23 – 49	19 – 45	28 – 58
#30			
#200	2 – 8	1 – 7	2- 10

(D) **HMA Material.** Binder (asphaltic cement) shall be from an approved source and shall meet the requirements listed in Table 702.2 *CDOT Standard Specifications for Road and Bridge Construction*. Based on climatic conditions and reliability, the binder grade approved for use in the Fruita area is (*See Inserted Table*).

<b>TABLE 4.4: RECOMMENDED BINDER GRADES</b>		
For City of Fruita, CO		
Condition	Non – Modified Binder	Modified Binder
Free flowing traffic loads, < 10,000,000 18K ESAL	PG 64 – 22	PG 64 - 28
Slow moving or standing trucks, Major street intersections, and/or >= 10,000,000 18K ESAL		PG 76 - 28
In lower layers of pavement	PG 58 – 22*	PG 58 – 28*

\* Use of a lesser grade of asphalt binder in the lower layers shall be evaluated based on economics and availability of a lesser grade binder.

(1) **Composition of Mixture.** The HMA plant mix shall be composed of a mixture of well-graded aggregate, filler (if required), bituminous material and anti-stripping additive. The several aggregate fractions shall be sized, handled in separate size groups and combined in such proportions that the resulting mixture meets the grading requirements of the job mix formula.

**Job Mix Formula.** The HMA job mix shall be consistent with that produced by local plants for CDOT use. In the absence of such design mix, the replacement mixture shall be approved by the City.

- (a) The job mix formula shall be submitted in typed form by the contractor to the City at least 10 days prior to the start of paving operations.

<b>TABLE 4.5</b>		<b>DESIGN CRITERIA</b>
<b>Test Property</b>	<b>Requirements</b>	
Stability	30 min	
Compaction Gyration (N design)	75*	
Air Voids (percent by volume of mix)	3.0 to 5.0	
Voids Filled (percent by volume of mix)	65 to 78	
Voids in Mineral Aggregate	See Table 5	

On roadways with high traffic loading, N design greater than 75 gyrations may be specified by the Engineer of record (See Table 2 – 1 in the CAPA *Guideline for the Design and Use of Asphalt Pavements for Colorado Roadways*)

<b>TABLE 4.6 **Voids in Mineral Aggregate (VMA)</b>				
<b>Nominal Maximum Particle Size*</b>		<b>Minimum VMA (percent)</b>		
		<b>Percent Design Air Voids</b>		
<b>Mm</b>	<b>In.</b>	<b>3.0</b>	<b>4.0</b>	<b>5.0</b>
9.5	3/8	14	15	16
12.5	1/2	13	14	15
19	3/4	12	13	14
25	1	11	12	13
37.5	1 – 1/2	10	11	12

\* The nominal maximum particle size is one sieve size larger than the first sieve to retain more than 10 percent. \*\* **This table is modified from the GJ Spec. Smallest size for GJ = #4 sieve of 16.0, 17.0, 18.0**

- (b) The maximum size aggregate used shall not be more than one-third (1/3) of the thickness of the lift being constructed. (3:1 ratio)
- (c) Job mix control testing shall be performed by the contractor at the start of plant production and in conjunction with calibration of the plant for the job mix formula. It should be recognized that the aggregates produced by the plant may not satisfy the gradation requirements or produce a mix that exactly meets the job mix formula. In those instances, it will be necessary to reevaluate and redesign the mix using plant-produced aggregates.

**(D) Testing Laboratory.** The laboratory used to develop the job mix formula shall meet the requirements of ASTM D 3666 and CDOT. All testing laboratories either developing the job mix formula or performing AQ or AC testing shall participate in a gyratory compactor

correlation procedure prior to each paving season. This will involve compaction of like samples, and applying a correction factor to the specific gravity of compacted specimens based on a mean value established from all collected data. Each laboratory will be notified by the manager of the laboratory stating that it meets these requirements shall be submitted to the City prior to the start of construction. The certification shall contain as a minimum:

- (a) Qualifications of laboratory manager, supervising technician and testing technicians.
- (b) A listing of equipment to be used in developing the job mix.
- (c) A copy of the laboratory's quality control system.
- (d) Evidence of participation in the AASHTO Materials Reference Laboratory (AMRL) program.

**(E) Job Mix Testing Requirements.** All commercial testing and laboratory work necessary to establish the job mix formula and all testing necessary to assure conformance of materials and workmanship to the requirements of the specifications shall be at the Contractor's expense. Two (2) copies of all test reports shall be submitted directly to the City.

**(F) Volumetric Tolerances.** HMA mix design volumetric tolerances for the approved HMA mixture shall be within the limits shown in Table 4.7. Mixture being produced by the plant shall be verified prior to the start of the placement of the mixture. Verification shall be performed by a **LabCAT Level C** certified technician to verify the volumetric properties of the mixture. If the mixture has been produced for another project within the last 90 days, verification results from that project may be submitted for this verification.

<b>TABLE 4.7: HMA MIXTURE DESIGN VERIFICATION TOLERANCES</b>	
<b>Property</b>	<b>Tolerances</b>
Air Voids	1.2%
VMA	1.2%
Binder Content	0.3%
Stability	Applicable Minimum

**(G) Lift Thickness.** Each lift of compacted HMA shall be of uniform thickness. The minimum compacted lift thickness shall be three (3) times the maximum nominal aggregate size. The maximum thickness shall be 3 inches unless the contractor can demonstrate the ability to achieve compaction of thicker lifts.

**(H) Patching.** All trenches and excavations in collector or arterial streets shall be patched before the street is reopened to traffic. All longitudinal trenches shall be repaved with an asphalt-paving machine. The contractor shall maintain all temporary patches until a permanent patch is installed. When local asphalt plants are closed, a cold patch will be required on all excavations in asphalt section of right-of-way.

Patches on newer pavements (less than 2 years old) shall be made with seamless joints using the infrared heating process described in paragraph I below, unless otherwise approved by the City.

**(I) Seamless Patching with Infrared Process:** This work shall consist of repairing asphalt pavement utilizing infrared equipment to heat the existing pavement adjacent to the areas to be patched and furnishing and placing new hot bituminous pavement on the prepared area. This method may also be used to repair temporary or hand placed patches that were made with hot bituminous pavement. This method of pavement repair is intended to provide a seamless patch restoring the disturbed area to a smooth, homogeneous pavement.

The equipment used for heating pavement must be capable of producing a true infrared ray with a minimum of convection heat. The area to be patched shall be cleaned and free of foreign matter within the treatment area. The infrared heater shall be positioned over the patch area in pavement. The heating time will be approximately seven (7) minutes, depending upon the ambient temperature and condition of the pavement. An experienced operator shall determine exactly when optimum-heating penetration has occurred. Overheating shall be avoided to prevent damage to the asphalt binder. After heating, the area to be patched shall be neatly outlined (picture framed) with the back of an asphalt rake. The boundary of this area shall be approximately six inches (6") within the heated area. Using the ling tongs of the asphalt rake, this area shall be thoroughly scarified. An asphalt-rejuvenating additive, if needed, shall be added during the scarifying process. New hot bituminous pavement (HMA) shall be added to bring the area up to grade allowing for compaction. The HMA shall be placed at a temperature between 270 and 300 degrees Fahrenheit. This may be accomplished by the use of an infrared storage unit or other approved method. Compaction shall be accomplished by the use of a vibratory pavement roller with capacity equal to a three to five ton static roller. Proper techniques shall be used to achieve the required density and surface smoothness in accordance with CDOT Section 401.05.2.

**(J) Patching Other Than Infrared Process:** Areas to be patched by methods other than the infrared process shall be vertically cut and squared to a neat line. Where the pavement is saw cut, the cut face adjacent to the patch shall be roughened with a hand tool or other approved method. The minimum width of the patch adjacent to a concrete curb or gutter shall be two (2) feet unless otherwise approved by the City. Longitudinal joints shall be located at the edge of a bike lane or at the center or edge of a traffic lane. Prior to patching, the cut edges of the existing pavement shall be tack coated with Emulsified Asphalt (slow setting). Hot bituminous pavement thickness. The total thickness of the patch shall not be less than that of the existing pavement.

**(K) Prime Coat.**

- (1) **Surface Prep.** Before applying the prime coat all loose material shall be removed from the surface. The portion of the surface prepared for treatment shall be dry and in satisfactory condition. Dust or contamination of prime coats shall require brooming and reapplication.
- (2) **Emulsified Application.** Asphalt Emulsified Prime (AEP) shall be applied in accordance with the manufactures recommendations. The prime coat shall be carefully applied. If excessive amounts of curb, sidewalks or other structures are sprayed with liquid asphalt, they shall be cleaned at the Contractor's expense. The prime coat shall not be

applied when the surface is excessively wet or when the atmospheric temperature is less than 40 degrees Fahrenheit, when precipitation is imminent, or as recommended by the manufacturer.

(3) **Curing.** Curing shall be required for all prime and tack coats. The prime or tack coat shall be sticky, or tacky, when cured. The length of time required for curing shall depend on the air temperature, humidity and wind conditions and shall be black when cured. The prime coat shall be allowed to cure for a minimum of 24 hours prior to the paving operation. If after the curing period the prime coat has not penetrated the base material, and the surface must be used by traffic, a suitable blotter material shall be applied in amounts needed to absorb excess liquid asphalt. The blotter material shall be dry, gritty sand.

(4) **Coverage.** Prime coat AE-P shall be uniformly applied at a rate of 0.3 gallons per square yard to the surface of the aggregate base course. Application rates for other approved prime coat materials shall be as specified in the Contract Documents or as directed by the City.

**(L) Tack Coat.** When tack coat is specified on the approved plans or required by the City, all materials and construction shall be in accordance with the requirements of the CDOT Standard Specifications, Section 407. Tack coat shall be applied where additional HMA is to be placed over existing asphalt or Portland cement surfaces. Tack coats shall not be required where HMA is less than twenty-four (24) hours old and remains free of dust, dirt or debris.

(1) **Surface Preparation.** Before applying the tack coat all loose material shall be removed from the surface. That portion of the surface prepared for treatment shall be dry and in satisfactory condition. Dust or contamination of prime or tack coats shall require brooming and reapplication.

(2) **Liquid Asphalt.** The liquid asphalt used for tack coat shall be an emulsified asphalt grade CSS-1h or SS-1h and shall satisfy the requirements of ASTM D977.

(3) **Application.** The surface shall be allowed to cure to permit drying and setting of the tack coat prior to the paving operation. A 1:1 dilution should be applied at the rate of 0.05 to 0.15 gallons per square yard. A wand, or hand spray nozzle attached to the spray bar can be used for applying tack to gutter faces, valve boxes, manholes and rings.

**(M) Surface Smoothness.** The final riding surfaces of all pavements are subject to testing by the 10-foot straightedge method. The Contractor shall furnish an approved 10-foot straightedge and depth gauge and provide an operator to aid the Engineer in testing the finished pavement surface. Areas to be tested shall be determined by the City. The variation between any two contacts with the surface shall not exceed 3/16 inch and shall be marked and corrected at the Contractor's expense.

**(N) Asphalt Content.** Asphalt content shall be determined a part of the Contractor's Quality Control. If the materials are within the specification limits, the lot shall be acceptable.



Volumetrics falling outside the limits of the job mix formula will warrant corrective action, which may include removal and replacement of the represented day's production.

**(O) Traffic Control Plan.** If a Traffic Control Plan (TCP) is required, then the Contractor shall furnish one. The TCP shall be prepared in accordance with part VI of the latest edition of the Manual on Uniform Traffic Control Devices (MUTCD). The Contractor shall submit the TCP to the City for review at least (2) working days before the construction.

**P) Weather Limitations.** Hot mix asphalt shall be placed only on properly constructed surfaces that are dry and free from snow, ice and frozen ground. The bituminous mixtures shall be placed in accordance with the temperature limits shown on the following table and only when weather conditions permit the pavement to be properly placed and finished, as determined by the City.

<b>TABLE 4.8: PLACEMENT TEMPERATURE LIMITATIONS</b>	
<b>Compacted Layer Thickness</b>	<b>Minimum Air and Surface Temperature Degrees, F°</b>
3 inches	35 °
Greater than 1 inch, but less than 3 inches	40°
Air temperature is taken in the shade. Surface is defined as the existing base on which the new pavement is to be placed.	

**4.6 Final Inspection and Acceptance.**

The acceptance of all road and bridge improvements by the City will be based on the following:

**(A) Inspection Results Submittal and Documentation.** Submittal of results of all required quality control/quality assurance (QC/QA) tests certified by the Engineer or a qualified independent laboratory, as requested by the City or Contract Documents.

**(B) Field Inspection.** Passing a final inspection of the work by the City.

**(C) Product Guarantee.** The Developer/contractor shall guarantee all portions of the street for a period of not less than one year after completion against defective workmanship and materials and shall keep the street in good repair during that period. The City may require a larger guarantee period if testing results are outside the acceptable range of these specifications. The determination of the necessity, during such guarantee period, for the Contractor to repair said street, or any portion thereof, shall rest entirely with the City, whose decision upon the matter shall be final and obligatory upon the Contractor.

**(D) As-built Drawings.** Developer/contractor shall submit final as-built drawings in hard copy and as an electronic AutoCAD file in accordance with the City of Fruita submittal standards in Chapter 1.

#### **4.7 Street System Details.**

- (A) Street and Driveway Standards
- (B) Roadway Notes
- (C) Driveway Detail w/Sidewalk Sections
- (D) Standard Accessible Parking Stall Detail
- (E) Accessible Parking Requirements
- (F) Paving and Concrete Typical Radii
- (G) Alley Section
- (H) Traffic Control – Bollards and Vehicle Barriers Flat and Round Post
- (I) Sight Distance Diagram

**4.7(A) Street and Driveway Standards**

<b>Public Street Standards (maintained by a Public Agency)</b>						
<b>Urban Street Classification ADT (Average Daily Traffic)</b>	<b>ROW (ft)</b>	<b>Pavement (ft)</b>	<b>Curb/Gutter</b>	<b>Sidewalk</b>	<b>Type Curb</b>	<b>On-Street Parking</b>
Local, residential 0-1000 ADT	44	28	Yes	Yes	Generally roll-over	Yes
Collector, residential 1000-3000 ADT	52	36	Yes	Yes	Vertical	No, with turn lane Yes, without turn lane
Collector, industrial 0-3000 ADT	48	36	Yes, v-pans where approved (5')	No	Vertical	No
Collector, commercial 0-3000 ADT	52	36	Yes	Yes	Vertical	No
Collector 3000-8000 ADT	60	44	Yes	Yes	Vertical	No
Pedestrian/Bicycle Path	12	8 minimum with base (concrete)	No, drainage designed	No	N/A	N/A
Greenway Drive Collector, Industrial	60	44	Yes	Yes Unattached	Vertical	No
Arterial	100	56 travel lanes 16 turn lane/median	Yes	Yes Unattached	Vertical	No

<b>Shared Driveway</b>						
<b>Maximum Density</b>	<b>ROW (ft)</b>	<b>Pavement (ft)</b>	<b>Curb/Gutter</b>	<b>Sidewalk</b>	<b>Type Curb</b>	<b>On-Street Parking</b>
<sup>1</sup> 2 dwelling units	Less than 20'	Considered on an individual basis	N/A	N/A	N/A	No
<sup>2</sup> 4 dwelling units	20' -26'	18' minimum	N/A	N/A	N/A	No

<sup>1</sup> Abutting property owners own land to middle of shared driveway – easements needed. Maintenance is equally shared by both owners.  
<sup>2</sup> Property owners serviced by the shared driveway are granted a perpetual easement by all other property owners whose property is crossed by the shared driveway. Maintenance is equally shared by all owners served by the driveway.

**Private Streets Standards (Not maintained by a Public Agency. Maintenance waiver required. Owned by private entity.)**

Built to same standards as Public Streets

**General Access Driveways**

Type	ROW (ft)	Pavement (ft)	Curb/Gutter	Sidewalk	Type Curb	On-Street Parking
Residential	N / A	12' minimum 32' maximum	N/A	N/A	N/A	N/A
Non-Residential	N / A	12' minimum 1 way 24' minimum 2 way	N/A	N/A	N/A	N/A

**Alternate Street Standards, Minimum Lane Widths for Residential Streets**

Width of Travel way		(1) Parking Lanes	Turning Lanes		(3) Bicycle Lanes
Minimum	Preferable		Minimum	(2) Preferable	
10 ft.	11 ft.	8 ft.	9 ft.	10-12 ft.	4 ft.

(1) Includes gutter pan

(2) Depends on number of trucks

(3) Minimum width, may increase depending on traffic lane widths and on-street parking.

ROADWAY NOTES:

1. GENERAL NOTATION LEGEND:

RIM = RIM OF MANHOLE ELEVATION

INV = INVERT ELEVATION OF MANHOLE OR INLET

CL = CENTERLINE

PL = PROPERTY LINE

FL = FLOWLINE

EL = ELEVATION

2. ASPHALT SHALL BE COMPACTED TO 92%-96% OF AN ACCEPTED SUPER PAVE DESIGN (SX-75).
3. PRIOR TO PAVING AND AFTER COMPACTION OF ROAD BASE, THE CONTRACTOR SHALL PROOF ROLL THE STREETS WITH A FULL WATER TRUCK. THE PROOF ROLLING WILL BE ACCOMPLISHED WHILE AN ENGINEERING INSPECTOR FOR THE CITY IS PRESENT. AREAS WHICH EXHIBIT PUMPING DETRIMENTAL TO THE STRUCTURAL INTEGRITY OF THE STREETS AS DETERMINED BY THE CITY'S INSPECTOR WILL BE ADDRESSED BY THE CONTRACTOR'S MATERIAL ENGINEER. THE STREET WILL BE RETESTED BY PROOF ROLL FOLLOWING REPAIRS.
4. CONTRACTOR TO PROTECT EXISTING UTILITIES AND APPURTENANCES. MANHOLES, CURB INLETS, UTILITY LINES, ETC., DAMAGED, COVERED OR FILLED WITH DIRT OR DEBRIS BY THE CONTRACTOR SHALL BE CLEANED AND REPAIRED TO THE CITY OF FRUITA'S STANDARDS, AT NO EXPENSE TO THE OWNER.
5. THE CONTRACTOR SHALL PROTECT THE SURFACE OF ALL CONCRETE AGAINST WEATHER, TRAFFIC, GRAFFITI AND SIMILAR ITEMS. ANY CONCRETE DAMAGED FOR ANY REASON SHALL BE REPAIRED BY CONTRACTOR AT CONTRACTOR'S EXPENSE TO MEET THE CITY OF FRUITA'S SPECIFICATIONS.
6. ANY CONCRETE CURB AND GUTTER, SIDEWALK, OR CROSSPAN DAMAGED BY COMPACTION EQUIPMENT DURING OR PRIOR TO PLACING, WILL BE REMOVED AND REPLACED BY CONTRACTOR AT CONTRACTOR'S EXPENSE.
7. CURB, GUTTER AND DRAINAGE PANS ARE TO HAVE EXPANSION JOINTS AT EACH CHANGE IN HORIZONTAL ALIGNMENT OF CURB AND GUTTER, BUT IN NO CASE AT A GREATER DISTANCE APART THAN 200'. LOCATE CONTROL JOINTS BETWEEN EXPANSION JOINTS AT INTERVALS NOT EXCEEDING 10'.
8. HANDICAP RAMPS ARE TO BE PROVIDED AT ALL CURB RETURNS AND SHALL BE IN ACCORDANCE WITH THE AMERICANS WITH DISABILITIES ACT AND CITY OF FRUITA STANDARDS.
9. INCLUDE BACKING OF CURB AND GUTTER AND/OR SIDEWALK WITH NATIVE FILL MATERIAL PER THE TYPICAL ROADWAY SECTION IN THE UNIT PRICE BID FOR EMBANKMENT.
10. HOT-MIX ASPHALTIC CONCRETE TO BE IN ACCORDANCE WITH CITY OF FRUITA STANDARDS AND SPECIFICATIONS. A MIX DESIGN FOR THE PROPOSED PIT MUST BE APPROVED BY THE ENGINEER PRIOR TO PLACEMENT OF PAVEMENT.
11. WHERE PROPOSED PAVEMENT IS TO MATCH EXISTING PAVEMENT, EXISTING PAVEMENT TO BE SQUARE CUT FOR THE FULL BASE THICKNESS. EXISTING SURFACE TO BE TACK COATED BEFORE NEW ASPHALT SURFACE IS PLACED. THE NEW ASPHALT SHALL MATCH AND BE FLUSH WITH EXISTING ASPHALT EDGE. NO LIP OR DEPRESSION WILL BE ALLOWED AS TESTED WITH A STRAIGHT EDGE AND SHALL BE REPAIRED BY THE CONTRACTOR IF THE TRANSITION EXCEEDS 1/4" PER 10' TOLERANCE.
12. THE FINISH SURFACE OF THE ASPHALT MAT MUST BE AT LEAST 1/4" ABOVE ANY ADJACENT CONCRETE SURFACE.
13. TRAFFIC SIGNS, CONTROL DEVICES, AND PAVEMENT STRIPING, SHALL COMPLY WITH MANUAL OF UNIFORM TRAFFIC CONTROL DEVICES (M.U.T.C.D.).
14. CONTRACTOR TO VERIFY ALL "TIE-IN" GRADES PRIOR TO ANY CONSTRUCTION AND SHALL REPORT ANY DISCREPANCIES TO THE DESIGN ENGINEER.
15. PAVEMENT DESIGN SHALL BE BASED UPON A GEOTECHNICAL INVESTIGATION REPORT PREPARED BY A CERTIFIED SOILS LAB.

CITY OF FRUITA  
ENGINEERING DEPARTMENT

SCALE  
HORIZONTAL: N/A  
VERTICAL: N/A

REVISION: 2009 STANDARDS REVISION      DATE: 3/18/09  
REVISION: \_\_\_\_\_      DATE: \_\_\_\_\_  
REVISION: \_\_\_\_\_      DATE: \_\_\_\_\_

ROADWAY NOTES

FILE:  
SHEET: 4/7B

DRAWN BY: CLD  
DATE DRAWN: 5/06  
CHECKED BY: \_\_\_\_\_

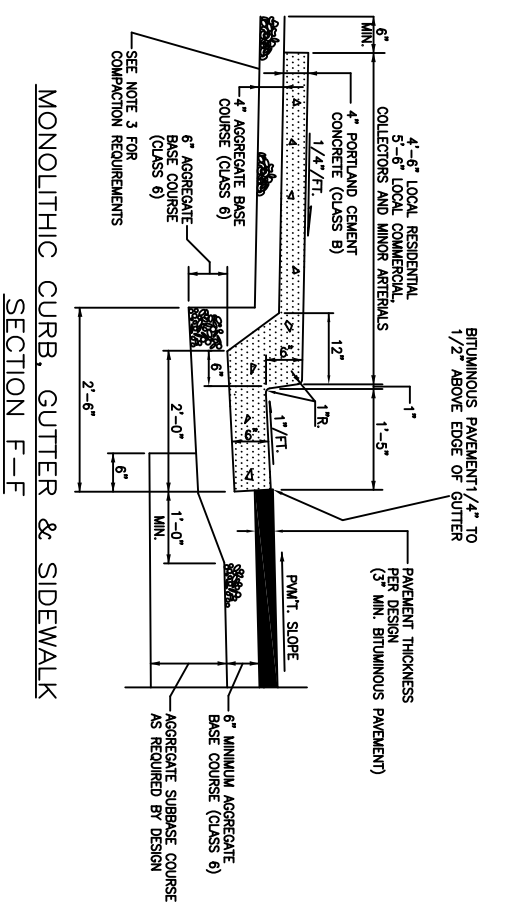
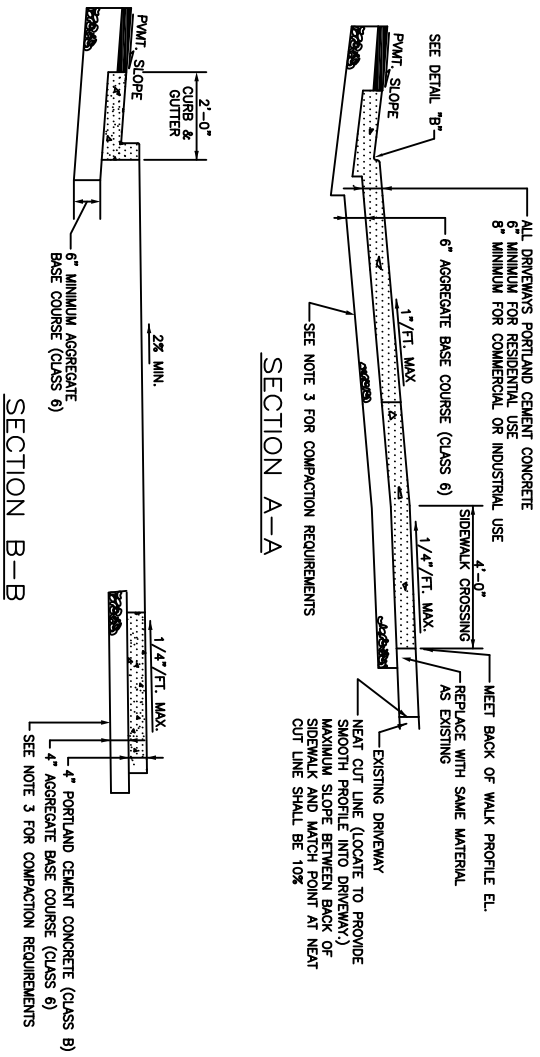
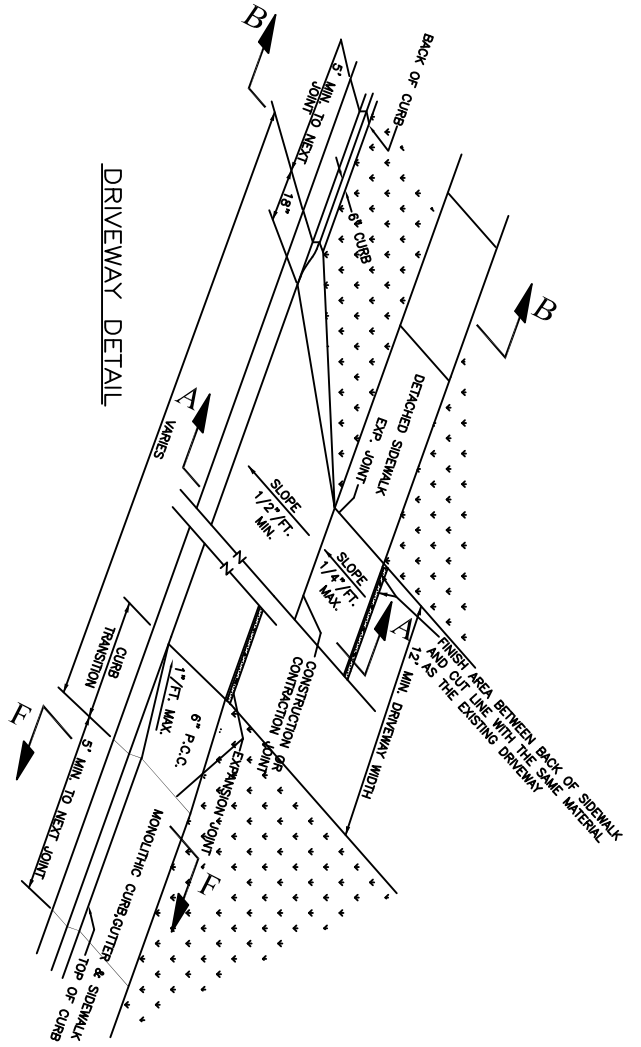

# STANDARD ACCESSIBLE PARKING STALL DETAIL

CITY OF FRUITA  
ENGINEERING DEPARTMENT

SCALE  
HORIZONTAL: N/A  
VERTICAL: N/A

REVISION: 2009 STANDARDS REVISION  
REVISION: \_\_\_\_\_  
REVISION: \_\_\_\_\_

DATE: 3/18/09  
DATE: \_\_\_\_\_  
DATE: \_\_\_\_\_

STANDARD ACCESSIBLE  
PARKING STALL DETAIL

FILE:  
SHEET: 4.7D

DRAWN BY: CLD  
DATE DRAWN: 5/06  
CHECKED BY: \_\_\_\_\_

A. ACCESSIBLE PARKING SPACES SHALL BE DESIGNATED AS RESERVED FOR THE DISABLED BY A SIGN SHOWING THE SYMBOL OF ACCESSIBILITY (SEE MUTCD FIGURE 3B-19). SPACES COMPLYING WITH NOTE B SHALL HAVE AN ADDITIONAL SIGN "VAN ACCESSIBLE" MOUNTED BELOW THE SYMBOL OF ACCESSIBILITY. SUCH SIGNS SHALL BE MOUNTED SO THEY CANNOT BE OBTURED BY A VEHICLE PARKED IN THE SPACE. B. ONE IN EVERY EIGHT ACCESSIBLE SPACES, BUT NOT LESS THAN ONE, SHALL BE SERVED BY AN ACCESS AISLE 96" WIDE AND SHALL BE DESIGNATED "VAN ACCESSIBLE" AS SPECIFIED BY NOTE A.

C. PARKING ACCESS AISLES SHALL BE PART OF AN ACCESS ROUTE TO THE BUILDING OR FACILITY ENTRANCE. TWO ACCESSIBLE PARKING SPACES MAY SHARE A COMMON ACCESS AISLE. PARKING SPACES AND ACCESS AISLES SHALL BE LEVEL WITH SURFACE SLOPES NOT EXCEEDING 1:50 IN ALL DIRECTIONS.

D. ACCESSIBLE CURB RAMPS AT INTERSECTIONS SHALL BE ALIGNED WITH STREET CROSSEWALKS.

E. THE MAXIMUM LONGITUDINAL SLOPE ALLOWED ON ANY CURB RAMP OR SIDEWALK SHALL BE 1" / FT. (8.33%). THE MAXIMUM CROSS SLOPE ALLOWED ON ANY WALKING ROUTE IS 1:50 (2%) (1/4" / FT.).

F. THE SURFACE OF ALL ACCESSIBLE RAMPS AND FLARED SIDES SHALL BE FINISHED WITH A COURSE BROOMED TEXTURE PERPENDICULAR TO THE SLOPE OF THE RAMP.

G. ALL HANDICAP RAMPS, PARKING STALLS AND LANDINGS, SHALL CONFORM TO THE UNIFORM FEDERAL ACCESSIBILITY STANDARDS (UFAS) LATEST EDITION.

**NOTES:**

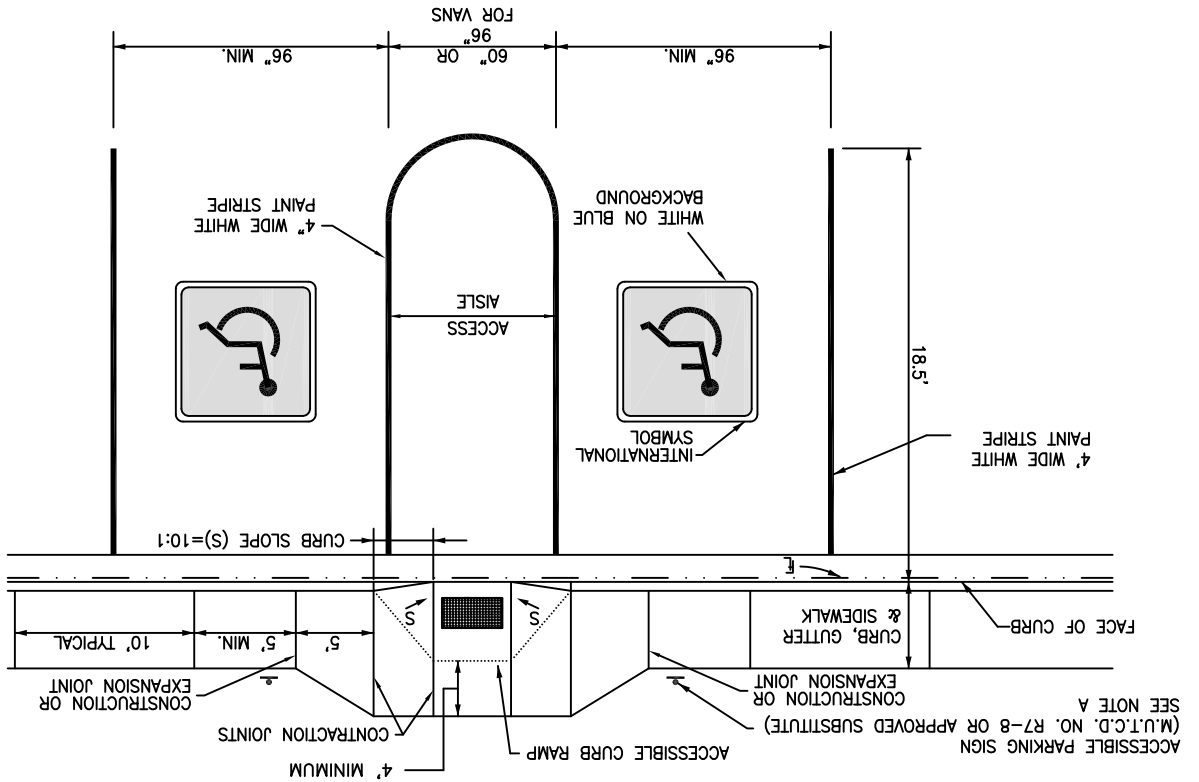

SEE NOTE A  
(M.U.T.C.D. NO. R7-8 OR APPROVED SUBSTITUTE)  
CONSTRUCTION OR  
EXPANSION JOINT

CURB, GUTTER  
& SIDEWALK

4" WIDE WHITE  
PAINT STRIPE

18.5'

WHITE ON BLUE  
BACKGROUND

INTERNATIONAL  
SYMBOL

96" MIN.

60" OR  
96"

FOR VANS

96" MIN.

ACCESSIBLE CURB RAMP

4' MINIMUM

CONTRACTION JOINTS

EXPANSION JOINT

10' TYPICAL

5'

5' MIN.

FACE OF CURB

### Minimum Number of Accessible Parking Spaces

Source: ADA Standards for Accessible Design 4.1.2(5)

Total Number of Parking Spaces Provided (per lot)	Total Minimum Number of Accessible Parking Spaces (with 60" access aisle, or 96" aisle for vans*)	Van Accessible Parking Spaces with Min. 96" Wide Access Aisle	Accessible Parking Spaces with Min. 60" Wide Access Aisle
1-25	Column A 1	1	0
26-50	2	1	1
51-75	3	1	2
76-100	4	1	3
101-150	5	1	4
151-200	6	1	5
201-300	7	1	6
301-400	8	1	7
401-500	9	2	7
501-1000	2% of Total Parking Provided in Each Lot	1/8 of Column A**	7/8 of Column A***
1001	20 Plus 1 for Each 100 over 1000	1/8 of Column A**	7/8 of Column A***

\*vans and cars may share access aisles

\*\* one out of every 8 accessible spaces

\*\*\*7 out of every 8 accessible parking spaces

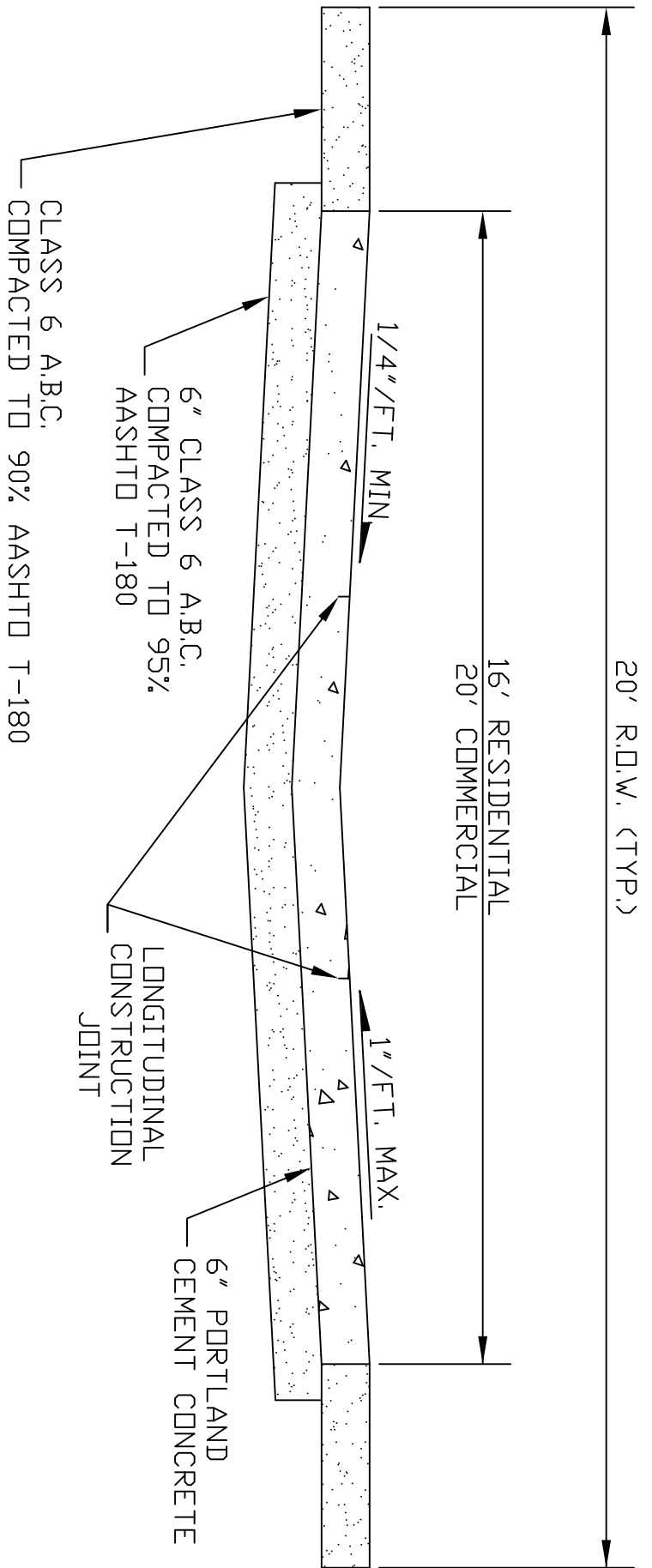

TABLE 1 – RADII AND RIGHT-OF-WAY WIDTH AT INTERSECTION CORNER

INTERSECTING STREETS	RADIUS TO FLOWLINE OF GUTTER
ARTERIAL – ARTERIAL	35'
ARTERIAL – ALL OTHER STREETS	35'
COLLECTOR – COLLECTOR	35'
COLLECTOR – RESIDENTIAL	25'
COLLECTOR – INDUSTRIAL	35'
RESIDENTIAL – RESIDENTIAL	20'
INDUSTRIAL – INDUSTRIAL	35'*

NOTE: USE COLLECTOR STREET DIMENSIONS FOR COMMERCIAL STREETS.

\* MINIMUM RADIUS=35' FOR GENERAL USE. REFER TO CHAPTER 4, SECTION 4.2H, STREET SYSTEM STANDARDS, CITY OF FRUITA DESIGN CRITERIA AND CONSTRUCTION SPECIFICATIONS.



TYPICAL ALLEY SECTION

NOTES:

1. SAWCUT LONGITUDINAL CONTRACTION JOINTS SPACED AT 1/3 PAVEMENT WIDTH
2. SAWCUT TRANSVERSE CONTRACTION JOINTS AT 10' SPACING
3. SEE CONCRETE NOTES DETAIL SHEET FOR EXPANSION JOINT SPACING
4. ALL EXPANSION AND CONTRACTION JOINTS SHALL BE SEALED

CITY OF FRUITA  
ENGINEERING DEPARTMENT

SCALE  
HORIZONTAL: N/A  
VERTICAL: N/A

REVISION: 2009 STANDARDS REVISION DATE: 3/18/09  
REVISION: \_\_\_\_\_ DATE: \_\_\_\_\_  
REVISION: \_\_\_\_\_ DATE: \_\_\_\_\_

ALLEY SECTION

FILE:  
SHEET: 4.76

DRAWN BY: CLD  
DATE DRAWN: 5/06  
CHECKED BY: \_\_\_\_\_

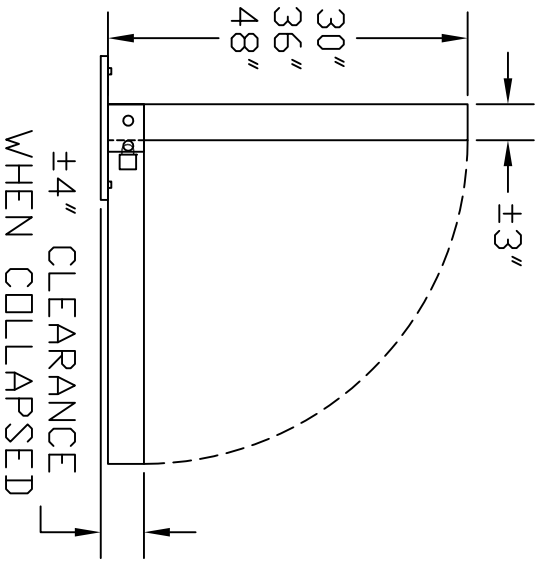
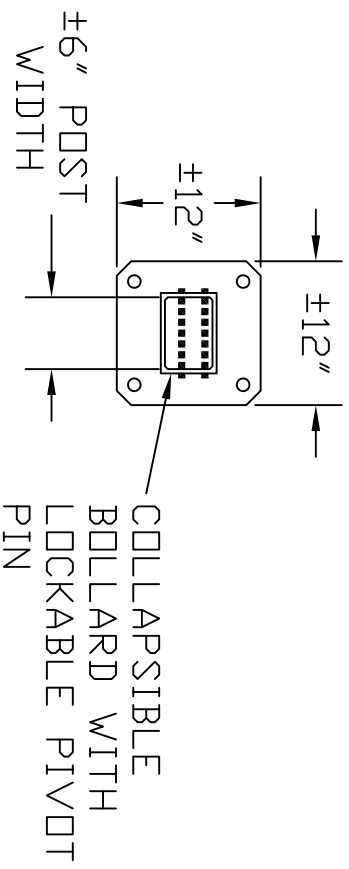

SQUARE BOLLARD

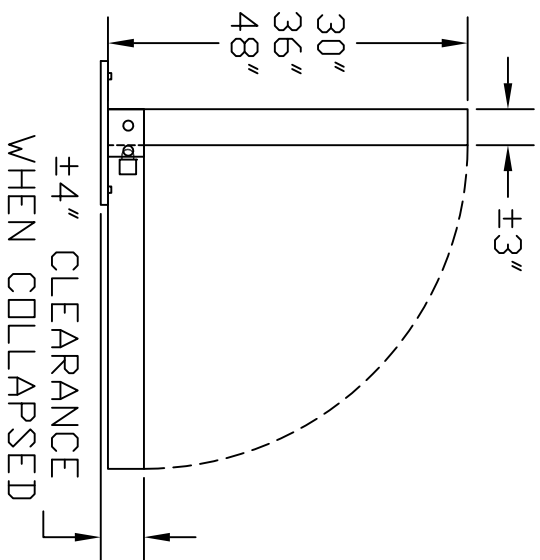
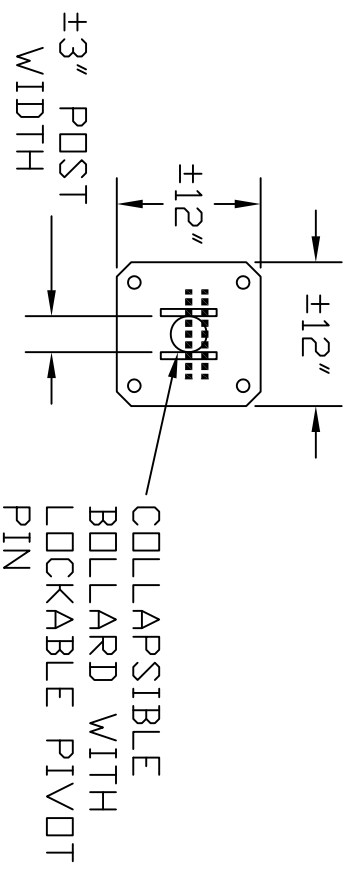

ROUND BOLLARD

SIGHT DISTANCE AT INTERSECTIONS INVOLVING A STOPPED CONDITION

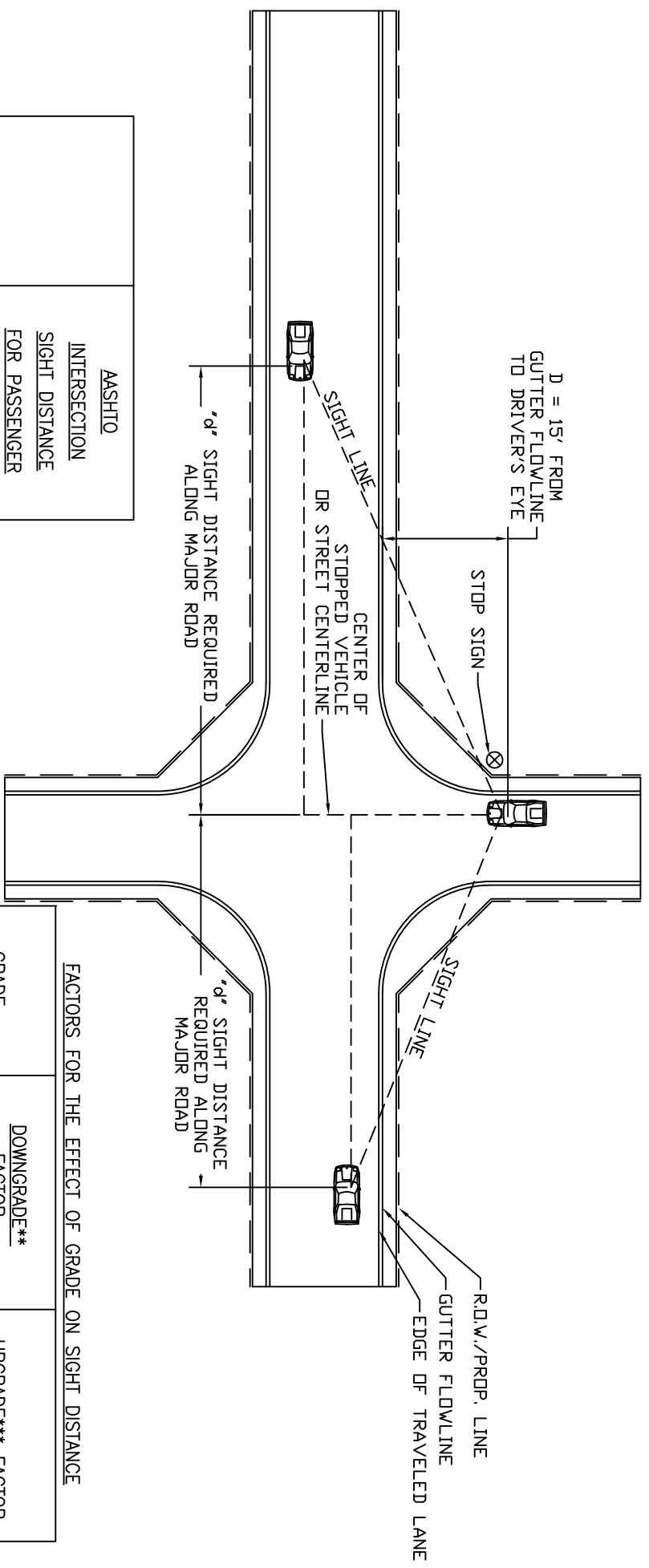

SPEED (MPH)	INTERSECTION SIGHT DISTANCE FOR PASSENGER CARS ("d")
20	225
25	280
30	335
35	390
40	445
45	500
50	555
55	610
60	665

FACTORS FOR THE EFFECT OF GRADE ON SIGHT DISTANCE

GRADE	DOWNGRADE** FACTOR	UPGRADE*** FACTOR
0 - 3%	1.0	1.0
3.1 - 5%	0.6	1.4
5.1 - 8%	0.5	1.7

\*\*WHEN THE STREET IN THE SECTION TO BE USED FOR ACCELERATION AFTER LEAVING THE ACCESS DESCENDS, SIGHT DISTANCE IN THE DIRECTION OF APPROACHING DESCENDING STREET TRAFFIC SHOULD BE REDUCED BY THESE FACTORS.

\*\*\*WHEN THE STREET IN THE SECTION TO BE USED FOR ACCELERATION AFTER LEAVING THE ACCESS ASCENDS, THEN SIGHT DISTANCE IN THE DIRECTION OF APPROACHING ASCENDING TRAFFIC SHOULD BE INCREASED BY THESE FACTORS.

\*MEASURED FROM THE DRIVER'S EYE FIFTEEN FEET (15') BACK OF THE FLOWLINE OR PAVEMENT EDGE. INTERSECTION SIGHT DISTANCE IS FOR A STOPPED PASSENGER CAR ENTERING A TWO-LANE STREET WITH GRADES 3% OR LESS.

## Chapter 5

### CONCRETE STANDARDS

#### Sections.

- 5.1: General Provisions
- 5.2: Mix Design Criteria
- 5.3: Materials Specifications
- 5.4: Concrete Placement
- 5.5: Joints and Joint Spacing
- 5.6: Finishing and Curing
- 5.7: Extreme Weather Protection
- 5.8: Testing, Final Inspection, and Acceptance
- 5.9: Flowcrete/Flowfill Specifications
- 5.10: Concrete Details

#### 5.1: General Provisions

- (A) **General.** Concrete work within any street, park, trail or alley ROW or in any part of the water system, wastewater system, parks and storm drainage system of the City shall meet the requirements of these Standards and Specifications. Engineering, plans, licenses, permits, inspection, warranties and acceptance shall be as detailed in these applicable Standards and Specifications for the type of construction involved.

For work within existing traveled rights-of-way, an excavation and right-of-way permit shall be obtained before work begins. Copies of the approved drawings and the permit shall be on the job site and available to the Inspector.

#### 5.2 Mix Design Criteria

- (A) **General.** All concrete designed, reinforcement, materials, mixing, placing finishing, etc. shall conform to American Concrete Institute (ACI) Codes, specifically Codes 301 and 318, latest edition.

- (B) **Classification.** The classification for all General Use or flatwork concrete in the City of Fruita shall conform to City of Grand Junction Section 601 – Class B Concrete. All structural work shall be CDOT Standards Specifications Table 601-1 Class D unless otherwise noted.
- (C) **Ready-Mixed Concrete.** The use of ready-mixed concrete in no way relieves the Responsible Party of the responsibility for proportion, mix, delivery or placement of concrete; concrete must conform to the requirements of these Standards and Specifications and ASTM C-94.

Concrete shall be continuously mixed or agitated from the time the water is added until the time of use and shall be completely discharged from the truck mixer or truck agitator within one and one-half (1½) hours after it comes in contact with the mixing water or with the aggregates. Re-tempered concrete shall not be allowed.

The City shall have free access to the mixing plant during times of operation. The organization supplying the concrete shall have sufficient plant and transportation facilities to assure continuous delivery of the concrete at the required rate. If requested, batch tickets shall be provided containing the following information:

- (a) weight and type of cement;
- (b) weights of fine and coarse aggregates;
- (c) volume (in gallons) of water including surface water on aggregates;
- (d) quantity (cubic yards) per batch;
- (e) times of batching and discharging of concrete;
- (f) name of batch plant;
- (g) name of person placing the order;
- (h) name and amount of admixture if approved;
- (i) date and truck number, and;
- (j) ticket number and cumulative total (per job).

### 5.3: **Materials Specifications**

**General.** Refer to ACI Code 301.

### 5.4: **Concrete Placement**

- (A) **General.** Before depositing concrete, debris shall be removed from the space to be occupied by the concrete and the forms, including any existing concrete surfaces, shall be thoroughly wetted. Concrete shall not be placed until forms and reinforcing steel have been inspected and approved by the City. Concrete shall be handled from the mixer to the place of final deposit as rapidly as possible by methods that prevent separation or loss of ingredients. The concrete shall be deposited in the forms as nearly as practicable in its final position to avoid re-handling. It shall be deposited in continuous layers, the thickness of

which generally shall not exceed twelve (12) inches. Concrete shall be placed in a manner that shall avoid segregation and shall not be dropped freely more than five (5) feet. If segregation occurs, the City may require the concrete to be removed and replaced at the Responsible Party's expense. Concrete shall be placed in one continuous operation, except where keyed construction joints are shown on the plans or as approved by the City. Concrete slump shall not exceed 4 inches. Delays in excess of thirty (30) minutes may require removal and replacement of that pour, as determined by the City.

- (B) **Subgrade Preparation.** The subgrade shall be excavated or filled to the required grades and lines. Soft, yielding or otherwise unsuitable material shall be removed and replaced with suitable material. Filled sections shall be compacted and compaction shall extend a minimum of six inches outside the form lines. The subgrade shall be compacted to the density shown on the plans and trimmed to provide a uniform surface at the correct elevation.
- (C) **Vibrating.** Concrete shall be thoroughly compacted and/or vibrated. Concrete shall be compacted by internal vibration using mechanical vibrating equipment, except that concrete in floor slabs, sidewalks, or curb and gutter, not poured against form linings, shall be either tamped or vibrated. Care shall be taken in vibrating the concrete to vibrate only long enough to bring a continuous film of mortar to the surface. Vibration shall stop before any segregation of the concrete occurs. Mechanical vibrators shall be an approved type as specified in CDOT Specifications 601.12e Concrete Vibrating. Vibrators shall not be used to move or spread the concrete.

Any evidence of the lack of consolidation or over-consolidation shall be regarded as sufficient reason to require the removal of the section involved and its replacement with new concrete at the Responsible Party's expense. The Responsible Party shall be responsible for any defects in the quality and appearance of the completed work.

- (D) **Workability.** The consistency of concrete shall be kept uniform for each class of work and shall be checked by means of slump tests. The workability of the concrete shall be varied as directed by the City. Concrete shall have a consistency such that it can be worked into corners and angles of the forms and around joints, dowels and tie-bars by the construction methods, which are being used without excessive spading, segregation or undue accumulation of water or latent material on the surface. If, through accident, intention, or error in mixing, concrete fails to conform to the proportions of the approved mix design, such concrete shall not be incorporated in the work but shall be properly disposed of off the project site as waste material at the Responsible Party's expense. If water is added at the job site, slump tests shall be run and test cylinders cast following the addition of the water. In no case shall concrete slump exceed four inches. Expenses incurred in excess of ordinary tests shall be borne by the Responsible Party.
- (E) **Backfilling.** When side forms are removed and the concrete has gained sufficient strength, the space adjoining the concrete shall be promptly backfilled with suitable material, properly compacted and brought flush with the surface of the concrete and adjoining

ground surface. In embankments, the backfill shall be level with the top of the concrete for at least two (2) feet and then sloped as shown on the drawings or as directed by the City.

- (F) **Detectable Warnings.** Detectable warnings shall be installed on new curb ramps and other locations where pedestrian ways blend with vehicular ways without tactile cues. Detectable warning surfaces shall consist of raised truncated domes with a diameter of nominal 0.9 in (23 mm), a height of nominal 0.2 in (5 mm) and a center-to-center spacing of nominal 2.35 in (60 mm). The domes shall be “in line” both parallel and perpendicular to the ramp to form a square grid pattern. The detectable warning shall contrast visually with adjoining surfaces, either light-on-dark, or dark-on-light. The domes and the underlying surface shall have a minimum of 70% contrast with the light reflectivity of the adjoining surface. Detectable warning surfaces shall extend 24 inches in the direction of pedestrian travel and shall match the width of the curb ramp (48” typical), landing or blended transition. The detectable surface shall be located so that the edge nearest the roadway is 6 inches minimum and 8 inches maximum from the face of curb line or from the edge of roadway where there is no curb.

An approved detectable warning plate or panel shall be “wet set” into the surface of freshly placed concrete during construction of each new curb ramp. Detectable warnings may be attached to the surface of hardened concrete only when retrofitting pre-existing curb ramps or when otherwise approved by the Engineering Manager.

The following detectable warning systems are approved for use in new curb ramp construction:

- Cast iron detectable Warning Plates manufactured by East Jordan Iron Works (800) 626-4653 or Neenah Foundry Company (303) 809-6315
- Cast iron detectable warning plates SWP2424 and SWP1224 furnished by Castings, Inc. (970) 243-2032
- Replaceable Composite (wet-set) Tactile manufactured by ADA Solutions, Inc. (800) 372-0519
- ADA Replaceable Tiles manufactured by ADA Replaceable Tiles (970) 245-3400

The following products are approved for retrofitting pre-existing curb ramps with surface applied detectable warnings:

- Armor-Tile Ridged Plastic Mat manufactured by Engineered Plastics, distributed by White Cap Construction Supplies (970) 245-6787
- Surface Mount composite Tactile manufactured by ADA Solutions, Inc. (800) 372-0519
- USA Safety Domes, Surface Mount System (800) 540-9277

All other detectable warning types, materials and manufacturers shall be approved by the City’s Engineering Manager prior to installation.

All detectable warnings, except cast iron plates, shall be brick red I color (note: yellow detectable warnings are being phased out and will not be allowed after June 30, 2009).



Detectable warnings shall be installed in accordance with the manufacturer's instructions and the City of Grand Junction Standard Concrete Detail C-23.

- (G) **Repairs.** After stripping of the forms, if any concrete is found to be not formed as shown on the drawings or is out of alignment or level, or shows a defective surface, it shall be considered as not conforming with the intent of these Standards and Specifications and shall be removed and replaced by the Responsible Party at his expense unless the City gives written permission to patch the defective area. In this case, patching shall be done as described in the following paragraphs. Defects that require replacement or repair are those that contain honeycomb, damage due to stripping of forms, loose pieces of concrete, bolt-holes, tie-rod holes, uneven or excessive ridges at form joints, and bulges due to movement of the forms. Ridges and bulges shall be removed by grinding. Honeycombed and other defective concrete that does not affect the integrity of the structure shall be chipped out, and the vacated areas shall be filled in a manner acceptable to the City. The repaired area shall be patched with a non-shrink, non-metallic grout with a minimum compressive strength of five thousand (5,000) psi in twenty-eight (28) days. Repair areas treated with an epoxy-bonding agent shall have the approval of the City before the repair filling is placed. Bolt-holes, tie-rod holes, and minor imperfections shall be filled with dry-patching mortar as approved by the City. Mortar repairs shall be placed in layers and thoroughly compacted by suitable tools. Care shall be taken in filling rod and bolt holes so that the entire depth of the hole is completely filled with compacted mortar. The mortar mix proportions described above are approximate.

Those areas with excessive deficiencies as determined by the City shall be removed and replaced at the Responsible Party's expense. Where repairs are made in existing sidewalks, all edges of the old sidewalk allowed to remain shall be saw cut to a minimum depth of two (2) inches. No rough edges shall be permitted where new construction joins the old section. Unless directed by the City, no section less than five (5) feet in length shall be placed or left in place. Where new sidewalk construction abuts existing sidewalks, the work shall be accomplished so that there is no abrupt change in grade between the old section and the new work.

No addition to existing sidewalks or other flat work concrete shall be made less than four (4) feet in width. The City may require doweling into the existing concrete.

### **5.5: Joints and Joint Spacing**

- (A) **Expansion Joint.** Expansion joint material shall be provided at the following locations and shall be in place prior to the placement of concrete:

- (1) At each end of curb returns.
- (2) Between back of sidewalk and driveway slab or service walk.
- (3) Between new concrete and existing masonry buildings.
- (4) As shown on the drawings.
- (5) As directed by the City Engineer.
- (6) Between new and existing concrete.
- (7) Every one hundred (100) feet in sidewalk curb and gutter when hand-formed.

(8) Every two hundred (200) feet in sidewalk, curb and gutter when placed slip formed.

- (B) **Contraction Joint.** Control joints shall have the same meaning as contraction joints. Construction joints referred to in subsection 608.03(e) of the CDOT Standard Specifications shall have the same meaning as isolation joints.

Transverse expansion joints shall be placed in curb, gutter and sidewalk at both ends of intersection radii and at other locations shown on the plans. The maximum spacing of expansion joints in continuous curb, gutter and/or sidewalk shall be 500 feet.

Isolation joints shall be placed around all appurtenances such as manholes, utility poles, sign posts, etc. and between new concrete and any fixed structure such as a building or bridge. Isolation joints and expansion joints shall be formed with preformed joint filler conforming to AASHTO M213 unless otherwise specified or approved. Preformed joint filler shall be extended to the full depth of the concrete section and be set or trimmed to ½ inch below the finished surface. All expansion and isolation joints shall be sealed in accordance with the detail shown in the Standard Concrete Details.

Curb, gutter and sidewalk shall be divided into uniform sections by forming contraction joints with a jointing tool, or by saw cutting after the concrete has hardened. Contraction joints in trails and detached sidewalks shall be made by saw cutting or with preformed plastic strips.

Contraction joints shall extend into the concrete at least ¼ of the depth of the concrete and shall be 1/8 to ¼ inch wide. Joints shall be spaced at intervals of (10) ten feet unless otherwise specified or approved. Where the length of a pour precludes even ten-foot joint spacing, the end section(s) may be less than (10) ten feet but not less than (5) five feet in length. Sawed joints shall be installed immediately after the concrete has hardened and before irregular shrinkage cracks form in concrete. When contraction joints are saw cut, hand tooled contraction joints shall be installed at intervals not to exceed (50) fifty feet to prevent shrinkage cracking before the remaining joints are cut.

Where new concrete is placed adjacent to existing concrete the joint type and spacing shall match to those in the existing concrete.

- (C) **Tool Joint.** Tool joints shall be spaced as follows:

- (1) Not more than ten (10) feet or less than five (5) feet apart in curb and gutter and combination curb-sidewalk.
- (2) Not more than the width of the sidewalk (up to eight (8) feet), nor less than five (5) feet apart in sidewalk.
- (3) At least two (2) joints equally spaced at not greater than ten (10) foot intervals applicable to driveways.

- (4) Joints shall be placed, in addition, at the mid-point of V-pans at street crossings.
- (5) Other locations as directed by the City or as shown on the plans.

(D) **Joint Materials.** Joint materials shall conform to AASHTO, ASTM Specifications according to type as follows:

	<u>AASHTO</u>	<u>ASTM</u>
Concrete joint sealer, hot poured elastic or	M173	D6690-01
Cold applied conforming to ASTM C920	C920	
Preformed expansion joint filler (Bituminous Type)	M 33	D99-98
Preformed sponge rubber and cork expansion joint fillers	M 153	D1752-84
Preformed expansion joint fillers, non-extruding and resilient bitumen	M 213	D1751-99

**5.6: Finishing and Curing**

(A) **Finishing.** Exposed faces of curbs and sidewalks shall be finished to true-line and grade as shown on the plans. Surface shall be floated to a smooth but not slippery finish. Sidewalk and curb shall be broomed or combed and edged, unless otherwise directed by the City. After completion of brooming and before concrete has taken its initial set, edges in contact with the forms shall be tooled with an edger having a three-eighths (3/8) inch radius. **No dusting or topping of the surface or sprinkling with water to facilitate finishing shall be permitted. A steel trowel finish is unacceptable for exposed concrete within City right-of-way.**

Immediately following the removal of the forms, fins and irregular projections shall be removed from surfaces except from those that are not to be exposed or are not to be waterproofed. On surfaces, the cavities produced by form ties, honeycomb spots, broken corners or edges and other defects, shall be thoroughly cleaned, moistened with water and carefully pointed and trued with a mortar consisting of cement and fine aggregate. The surface shall be left sound, of acceptable finish, even, and uniform in color. Mortar used in pointing shall not be more than thirty (30) minutes old. Construction and expansion joints in the completed work shall be left carefully tooled and free of mortar and concrete. The joint filler shall be left exposed for its full length with clean and true edges.

(B) **Curing.** All flatwork and all slip formed combination curb/ gutter/ sidewalk shall be coated with an approved spray applied curing compound. Fresh concrete shall be protected from weather damage and mechanical injury during the curing periods. The use of a

membrane-curing compound is required. Membrane curing compound shall be Type 2, Class B in accordance with CDOT Specification 711.01 Concrete Curing Materials. The membrane-curing compound shall be applied at the rate of three hundred (300) square feet per gallon.

Membrane curing compound shall not be used when the concrete surface will be painted. The type of membrane curing compound chosen shall not permanently discolor the concrete surface. Where membrane-curing compound is not used, the curing process shall be carefully adhered to as follows:

- (1) Optional curing processes described herein may be used at discretion of the City. The selected curing process shall be started as soon as it can be done without injury to the concrete surface. The following curing procedures may be used subject to the approval of the City.
  - (a) Ponding (for slabs or footings)
  - (b) Wet burlap, earth or cotton mats
  - (c) Waterproof paper or polyethylene plastic cover

- (B) Concrete that is poorly finished or improperly cured shall be removed at the City's discretion.

## **5.7 Extreme Weather Protection**

- (A) **Cold Weather Concreting.** A period when more than three successive days of average daily outdoor temperature is below 40° F (the average of the highest and lowest temperatures from midnight to midnight) constitutes cold weather concreting conditions. During cold weather concreting conditions, concrete construction shall be accomplished in accordance with CDOT Specifications 601.12 (c) and ACI 306-R88. November, December, January, February, and March are designated as cold weather months and require concrete protection regardless of temperature. In all cases, the concrete supplier shall furnish concrete suitable for placement in cold weather conditions.
- (B) **Proper Placing and Protection of Concrete.** Insulated blankets are required as cover for concrete placed during cold weather. It is the responsibility of the contractor, in extreme conditions, to determine if additional measures are needed to maintain the temperature requirements. The following prohibitions and conditions shall be in effect during cold weather:
  - (1) Concrete shall not be placed on frozen subgrade.
  - (2) Concrete shall not be placed on or against forms covered with snow or ice.

- (3) Insulating materials shall be available and easily accessible.
- (4) Avoid direct contact of fresh concrete with carbon dioxide emitted from poorly ventilated space heaters.
- (5) Always use ASTM approved curing compounds to insure proper curing and to prevent rapid drying and loss of moisture.
- (6) Maintain concrete at 55° F for three days (two days if ad-mixture is used). If the temperature requirements are not met, the concrete must continue to be protected until twice the deficiency in degree-days is met. For example, if the average temperature for the three days was maintained at 50° F (5° below the requirement), the concrete will need to be maintained at 65° (twice the deficiency) for an additional three days, or at 55° for an additional 6 days.

In practice, if the contractor is unable to maintain 55° F, he may also be unable to provide the increased protection requirement, three days after placement, without the use of heat generating equipment. Failure to provide the additional protection required, after first failing to provide the three days at 55° F, shall be grounds for rejecting the concrete.

**Note: If the concrete is found to have frozen in the first 24 hours, it shall be rejected.**

- (C) **Hot Weather Concreting.** Except by written authorization, concrete shall not be placed if the temperature of the plastic concrete cannot be maintained at ninety (90) degrees Fahrenheit or lower. The placement of concrete in hot weather shall comply with CDOT Specification 601.12 Placing Concrete.

## **5.8 Testing, Final Inspection and Acceptance**

- (A) **General.** The requirements of this section shall apply to testing services for concrete curb and gutter, sidewalk, pavement, slope paving, retaining walls, structures, and for miscellaneous concrete testing. Refer to Table 4.1 for testing requirements.

Concrete materials and operations shall be tested as directed by the City and as herein stipulated. The required testing services shall be performed by a testing agency approved by the City and testing agencies shall meet the requirements of ASTM E329.

A representative of the testing agency shall inspect, sample, and test material and production of concrete as required by the City at the Responsible Party's expense. When it appears that any material furnished or work performed by the Responsible Party fails to fulfill specification requirements, the testing agency shall report such deficiency to the City and the Responsible Party.

The testing agency shall report test and inspection results to the City and Responsible Party immediately after they are performed. Test reports shall include the exact location of the work at which the batch represented by a test was deposited. The report of the strength test shall include detailed information on storage and curing of specimen prior to testing, the project number and the location of the concrete (curb, manhole, inlet, sidewalk, paving, etc.). Test reports shall bear the seal and signature of a PE registered in the State of Colorado and competent in the field of concrete testing. Reports not properly certified shall not be accepted.

The testing agency or its representative is not authorized to revoke, alter, relax, enlarge or release any requirements of these Standards and Specifications, nor approve or accept any portion of the work.

- (B) The acceptance of all concrete improvements by the City will be based on the following.
- (1) Submittal of all required test results certified by the Engineer or a qualified independent laboratory.
  - (2) Submittal of a copy of the daily inspection reports prepared by the Engineer or his representative.
  - (3) Passing a final inspection of the work by the City

#### **5.9: Flowcrete/Flowfill Specifications**

- (A) **General.** There are many flow-fill mix designs available from local concrete producers that represent a variety of construction conditions. A minimum of 50 psi compressive strength will be required for all conditions. Each contractor is required to submit the specific proposed design mix to the City. Written approval by the City is required prior to commencing with the flow-fill work.

#### **5.10: Concrete Details**

- A. Accessible Detail Notes**
- B. Detectable Warning Curb Ramp**
- C. Ramp in Curb, Gutter and Sidewalk w/Fillet**
- D. Ramp with Monolithic Curb, Gutter and Sidewalk**
- E. Ramp with Detached Sidewalk**
- F. Ramps at Intersecting Sidewalks**
- G. Retrofit Ramp Existing Streets**

**H. Intersection and Pan Details and Sections**

**I. Driveway Detail w/Sidewalk Sections**

**J. Drive-over Curb, Gutter and Sidewalk**

**K. Curb and Gutter Details**

**L. Drive-over Curb and Gutter Detail**

**M. Concrete Joint Details**

**N. Flow-fill**

1. All general use Portland Cement Concrete shall conform to the City of Grand Junction Specification 601 (structural concrete Class B). All concrete shall be mixed, placed, cured and tested in accordance with City of Fruita street construction specifications. All structural work shall be CDOT Standard Specifications Table 601-1 Class D, unless otherwise noted.
2. All concrete work within public right-of-way shall be performed by a licensed curb, gutter & sidewalk contractor. A permit is required at each site where concrete is removed, altered or placed.
3. All concrete ramps, sidewalks, curbs, gutters and other concrete work shall be underlaid with aggregate base course (class 6) compacted to at least 95% of AASHTO T-180 maximum density. See details for base thickness. The top 6" of subgrade under all concrete shall be compacted to at least 95% of AASHTO T-99 maximum density. All saturated or unsuitable subgrade material shall be removed and replaced.
4. Any existing pavement not designated for removal which is damaged by construction shall be replaced in-kind by contractor.
5. Drawing indicates typical sections only. Conditions and/or obstructions may necessitate variations or repositioning. All locations shall be approved on an individual basis by the City Engineer or his/her representative.
6. Accessible curb ramps at intersections shall be aligned with street crosswalks.
7. An approved curing/sealing compound shall be applied to all exposed concrete surface immediately after finishing (refer to section 5.6(B)).
8. All concrete shall be protected from freezing for 5 days after being placed. No concrete shall be placed on frozen ground.
9. Minimum spacing between joints in curb, gutter & sidewalk is 5'. Maximum spacing is 10'.
10. Water shall not be added to concrete surfaces during finishing operations.
11. The surface of all accessible ramps and flared sides shall be finished with a course broomed texture perpendicular to the slope of the ramp.
12. All handicap ramps, parking stalls and landings shall conform to the Uniform Federal Accessibility Standards (UFAS) latest edition.

CITY OF FRUITA  
ENGINEERING DEPARTMENT

SCALE  
HORIZONTAL: N/A  
VERTICAL: N/A

REVISION: 2009 STANDARDS REVISION DATE: 3/18/09  
REVISION: \_\_\_\_\_ DATE: \_\_\_\_\_  
REVISION: \_\_\_\_\_ DATE: \_\_\_\_\_

ACCESSIBLE DETAILS NOTES

FILE:  
SHEET: 5.10A

DRAWN BY: CLD  
DATE DRAWN: 5/06  
CHECKED BY: \_\_\_\_\_



DETECTABLE WARNING:  
 AN APPROVED DETECTABLE WARNING SHALL BE "WET SET" INTO THE FRESHLY FINISHED CONCRETE SURFACE OF EACH NEW CURB RAMP. SURFACE APPLIED DETECTABLE WARNINGS MAY BE USED ONLY FOR RETROFITTING PRE-EXISTING CURB RAMPS. SEE SECTION 608.03, PARAGRAPH (!) OF THE CITY OF GRAND JUNCTION STANDARD SPECIFICATIONS FOR ROAD AND BRIDGE CONSTRUCTION FOR APPROVED DETECTABLE WARNING MATERIALS AND MANUFACTURERS. DETECTABLE WARNING SHALL BE INSTALLED IN ACCORDANCE WITH THE MANUFACTURER'S INSTRUCTIONS UNLESS OTHERWISE APPROVED.

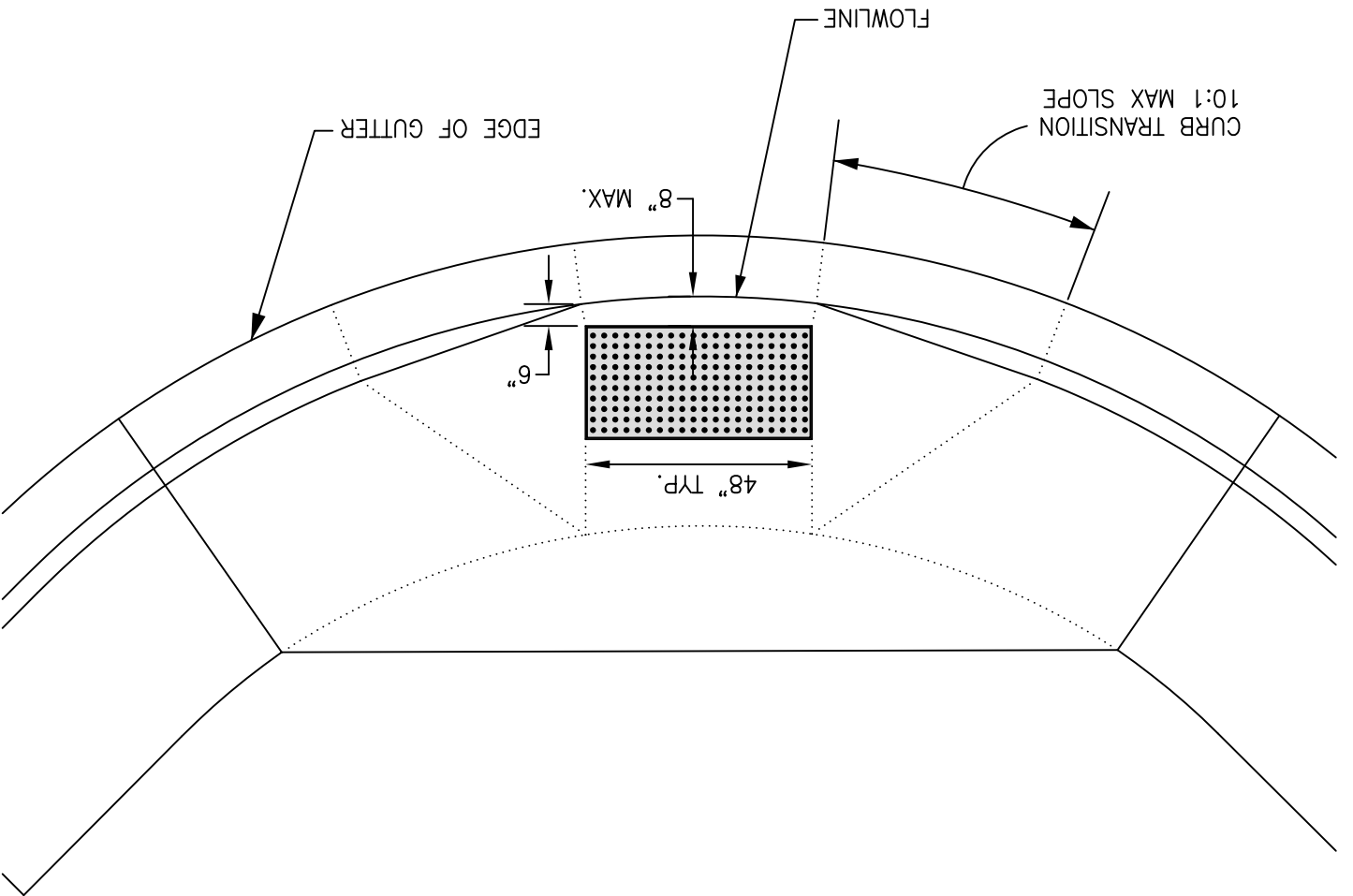
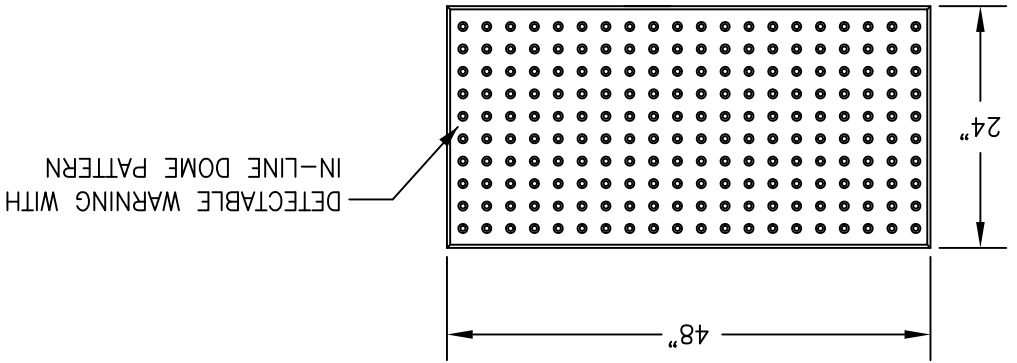

CITY OF FRUITA  
 ENGINEERING DEPARTMENT

SCALE  
 HORIZONTAL: N/A  
 VERTICAL: N/A

REVISION: 2009 STANDARDS REVISION  
 REVISION: \_\_\_\_\_  
 REVISION: \_\_\_\_\_

DATE: 3/18/09  
 DATE: \_\_\_\_\_  
 DATE: \_\_\_\_\_

DETECTABLE WARNING  
 FOR CURB RAMP

FILE:  
 SHEET: 5.10B

DRAWN BY: CLD  
 DATE DRAWN: 5/06  
 CHECKED BY: \_\_\_\_\_

RAMP IN MONOLITHIC CURB, GUTTER AND SIDEWALK  
WITH CONCRETE FILLET

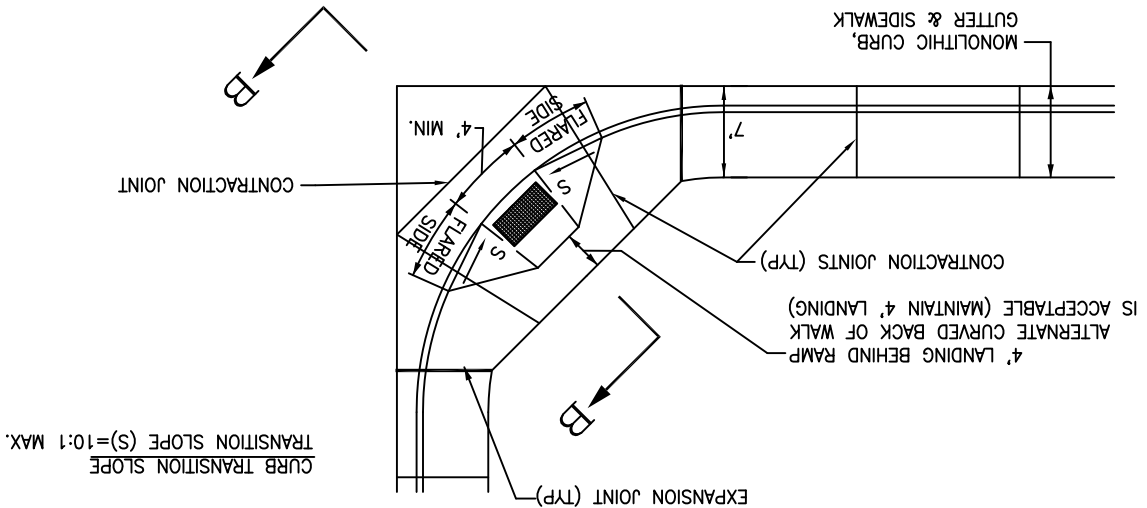
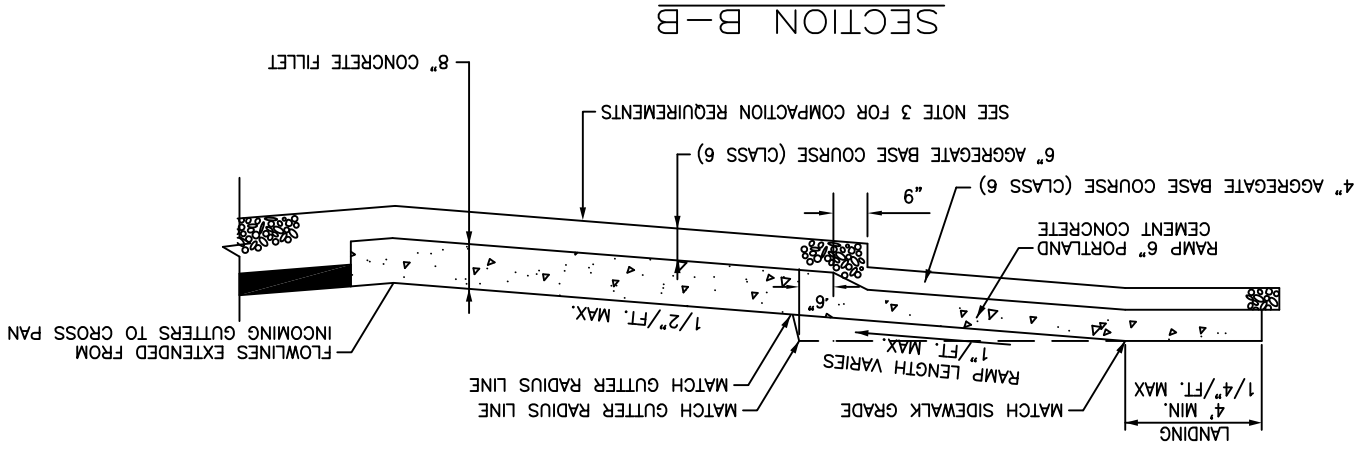

RAMP IN MONOLITHIC CURB, GUTTER AND SIDEWALK

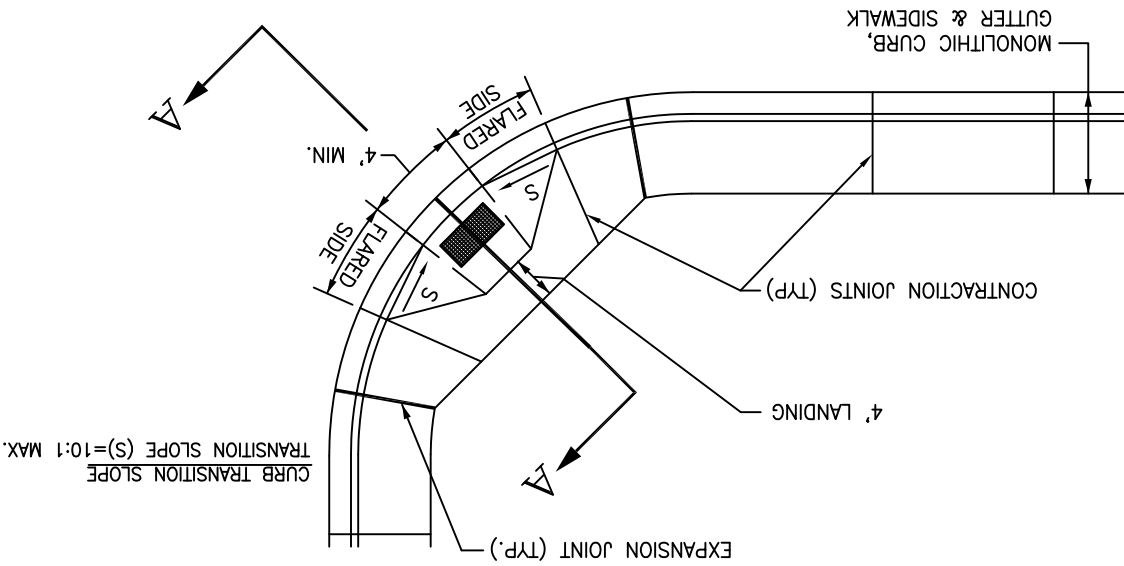
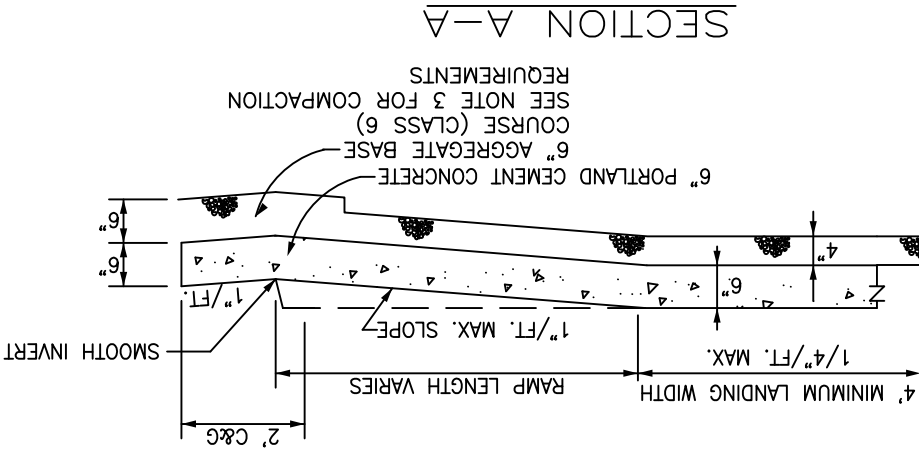

CURB RAMP WITH DETACHED SIDEWALKS

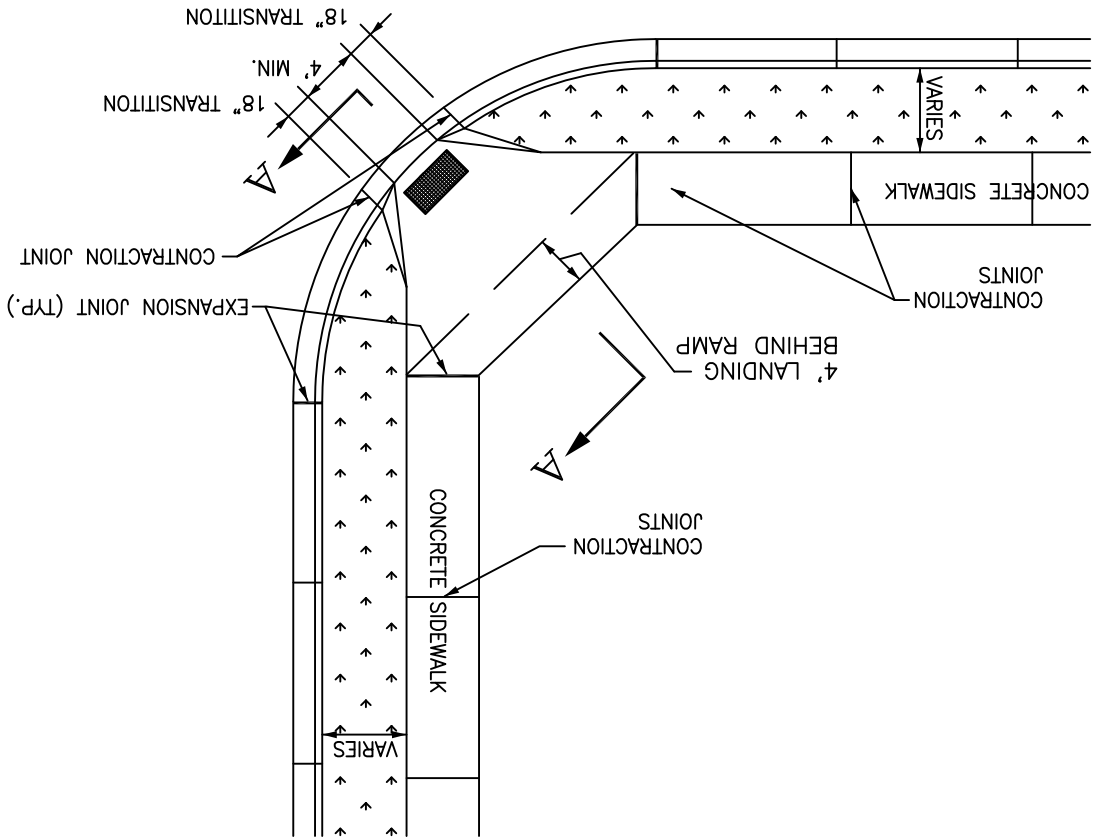

SECTION A-A

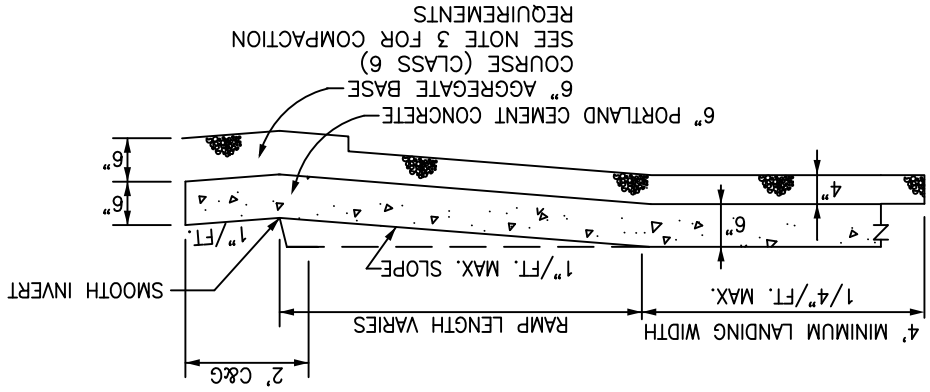

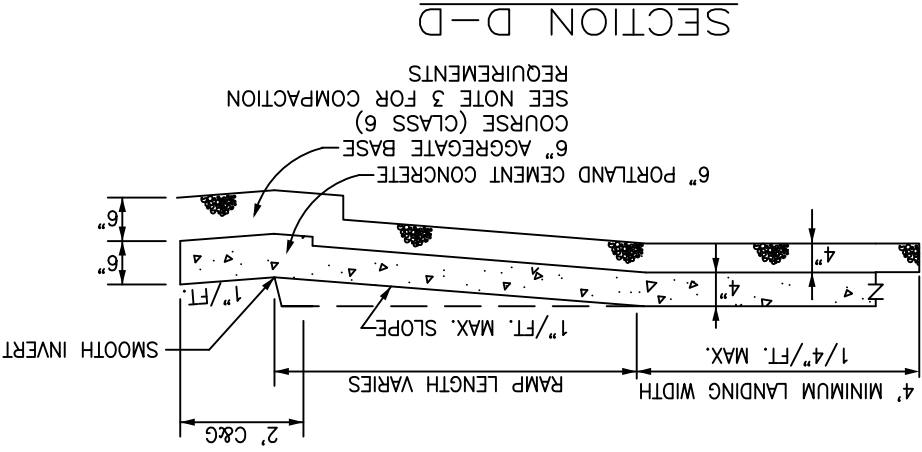

CURB RAMP(S) AT INTERSECTING SIDEWALK

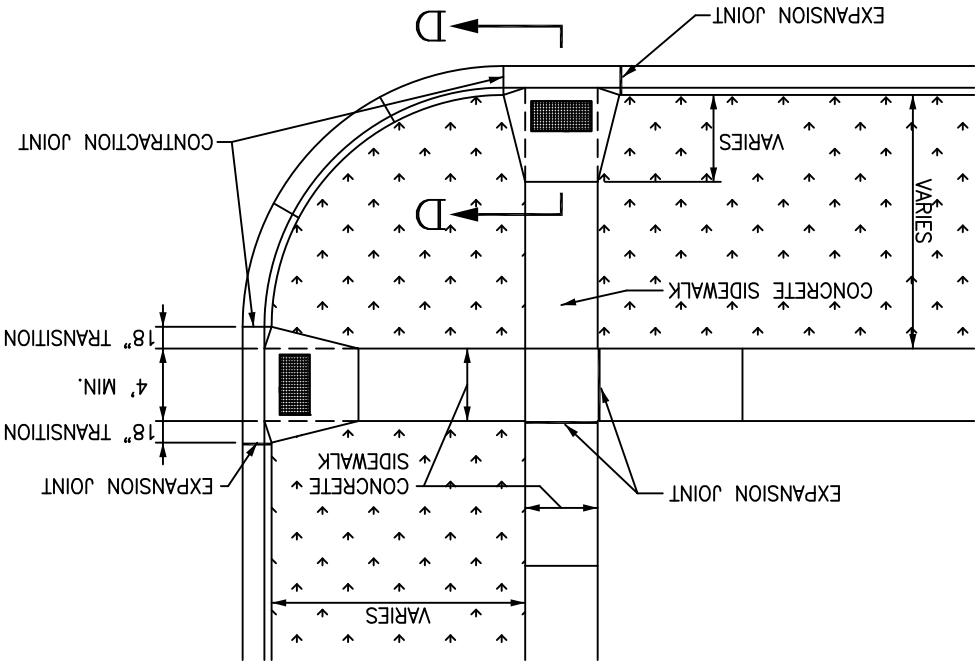

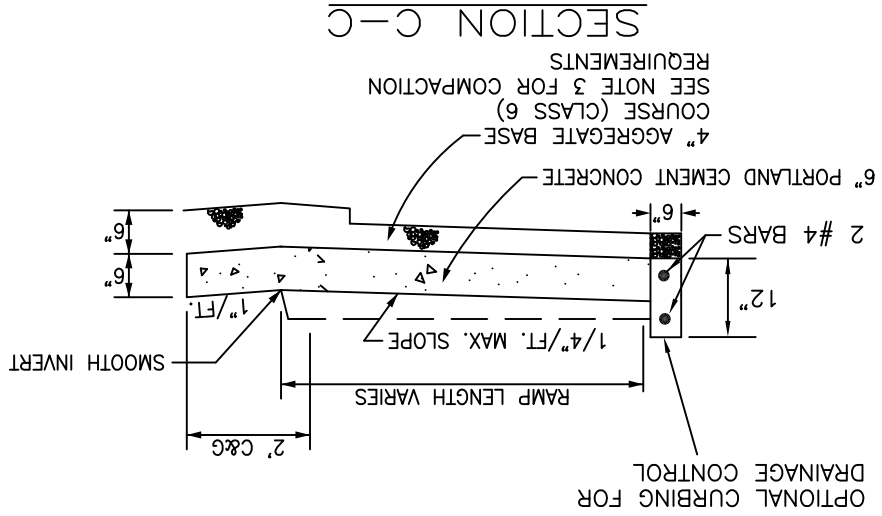

ALTERNATE RAMP  
WITHOUT LANDING BEHIND RAMP  
(FOR RETROFIT ON EXISTING STREETS ONLY)

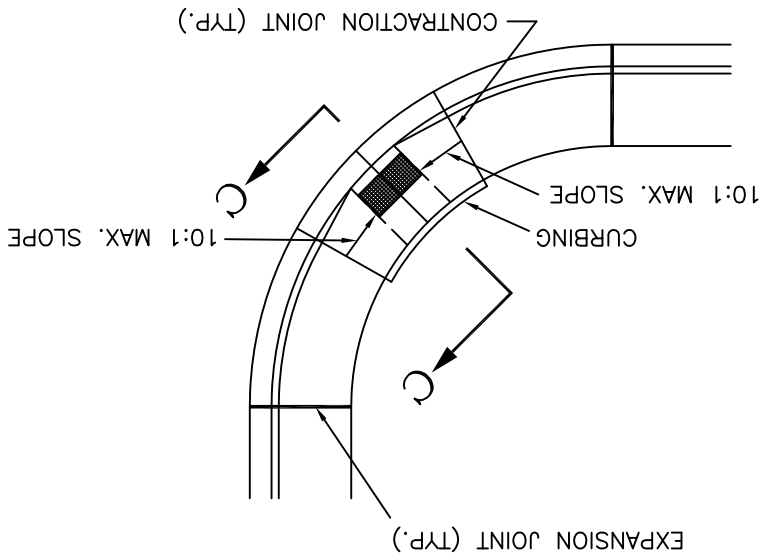

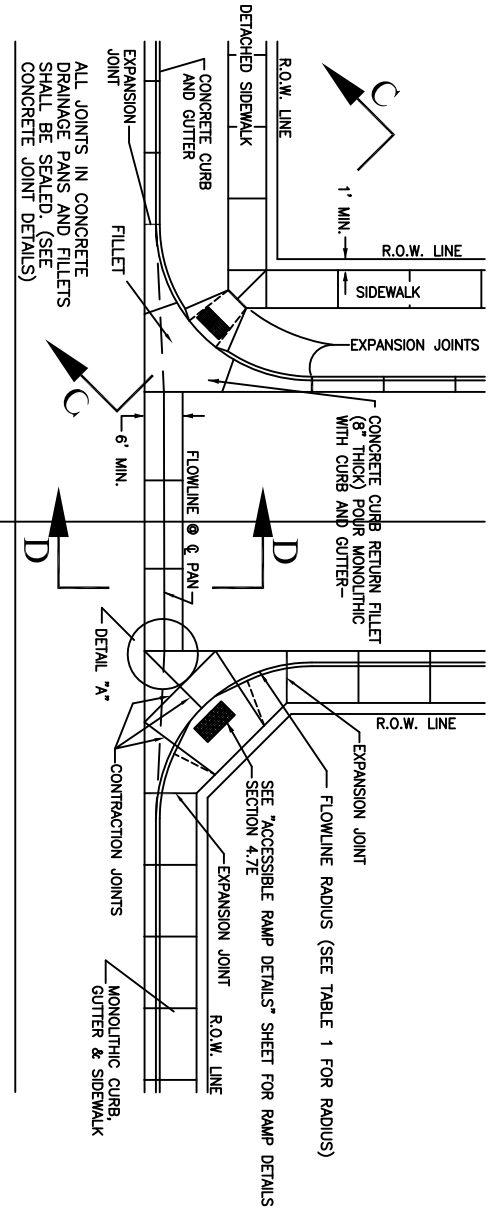
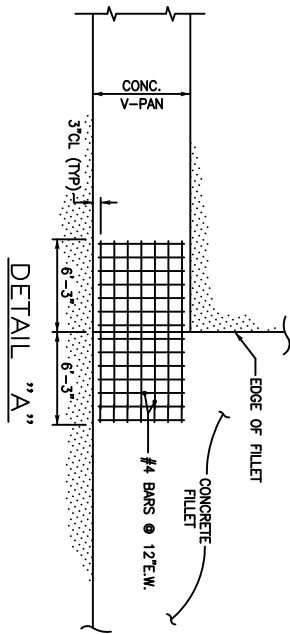

NOTE: DRAINAGE PANS ARE NOT ALLOWED ACROSS COLLECTORS OR ARTERIAL STREETS

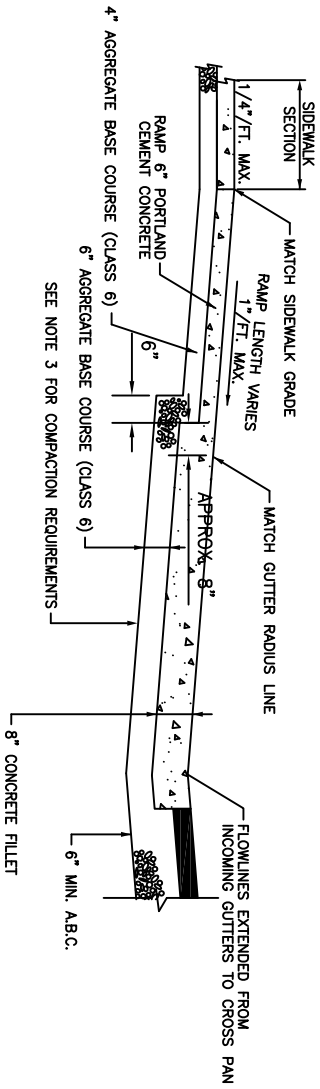

SECTION C-C

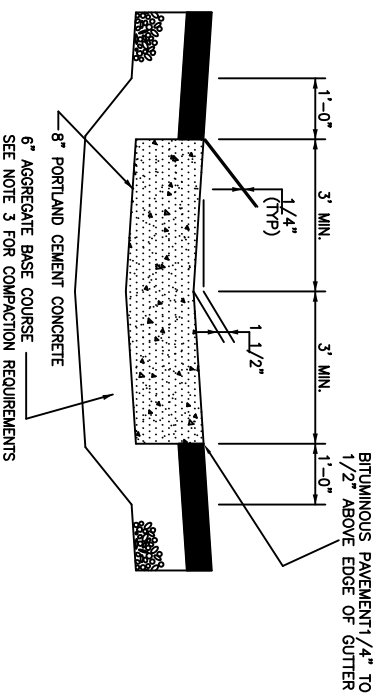

SECTION D-D

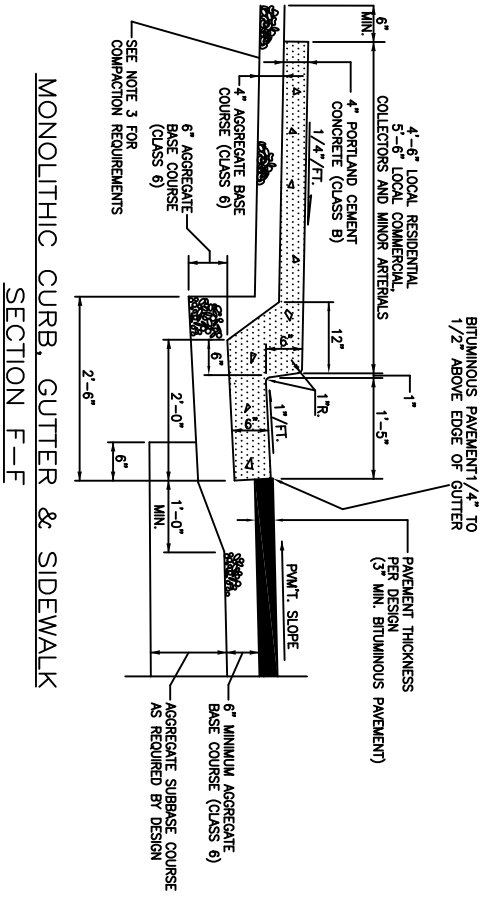
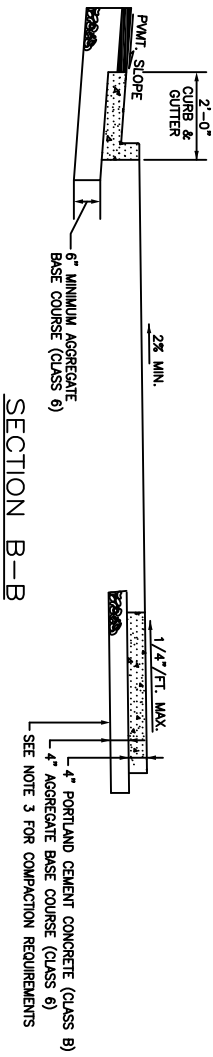
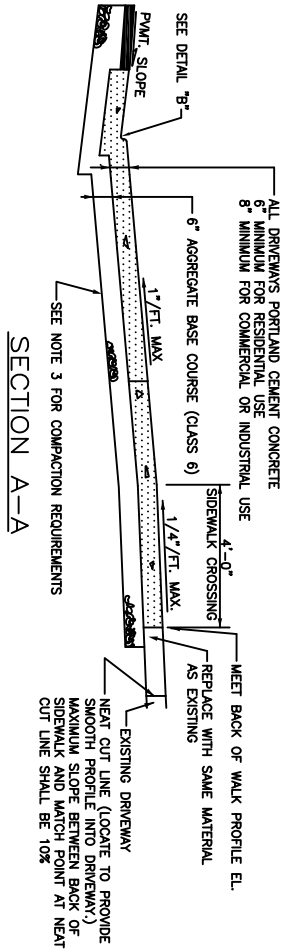
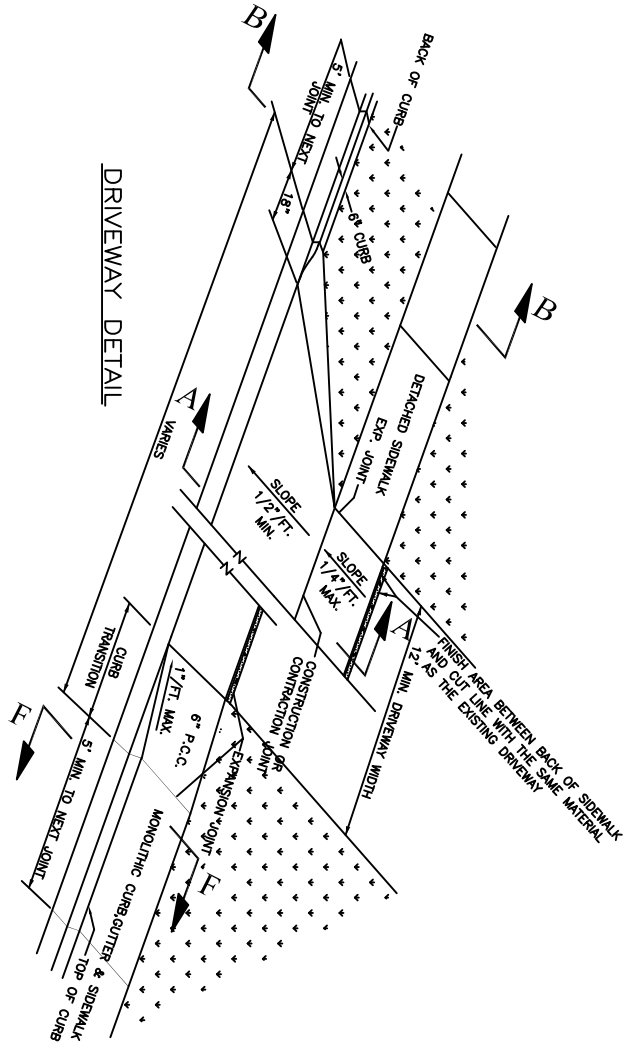



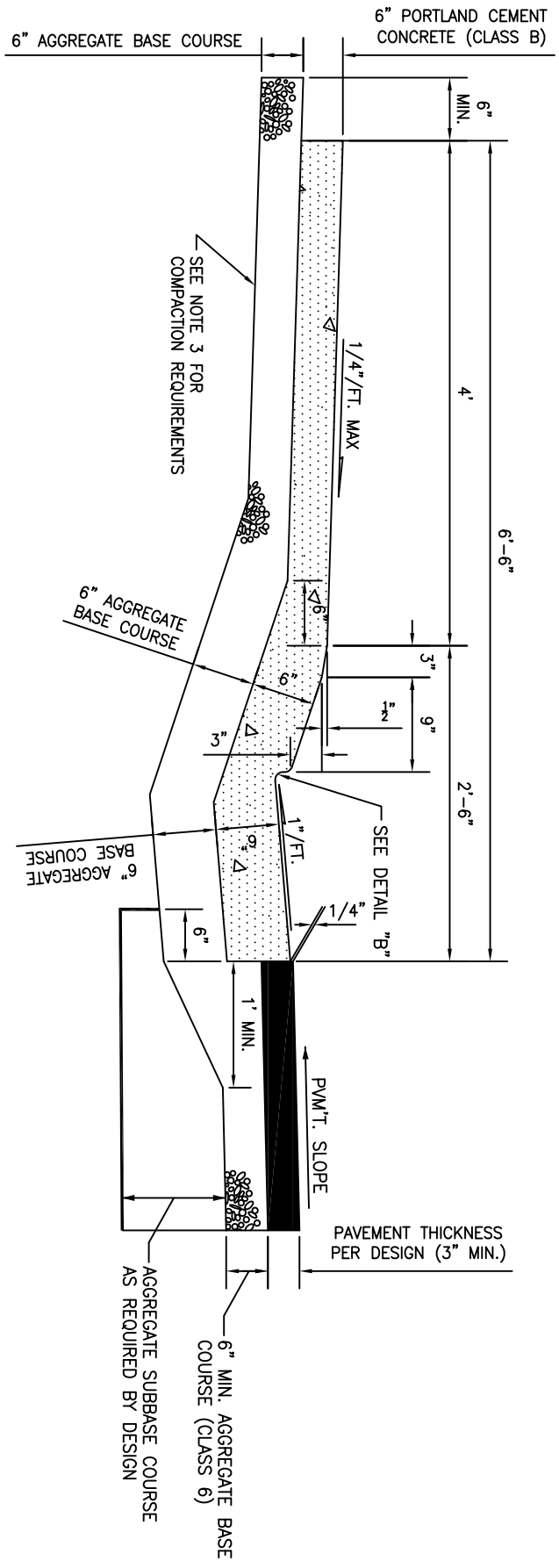

DRIVE-OVER CURB, GUTTER & SIDEWALK  
(URBAN RESIDENTIAL STREETS ONLY)

DETAIL "B"

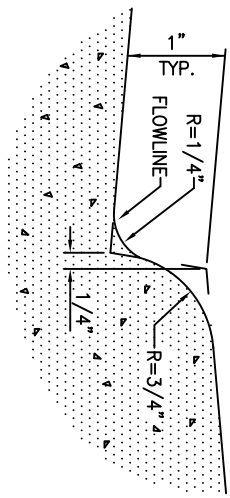

CITY OF FRUITA  
 ENGINEERING DEPARTMENT

SCALE  
 HORIZONTAL: N/A  
 VERTICAL: N/A

REVISION: 2009 STANDARDS REVISION  
 REVISION: \_\_\_\_\_ DATE: 3/18/09  
 REVISION: \_\_\_\_\_ DATE: \_\_\_\_\_

DRIVE-OVER CURB, GUTTER &  
 SIDEWALK

FILE:  
 SHEET: 5.10J

DRAWN BY: CLD  
 DATE DRAWN: 5/06  
 CHECKED BY: \_\_\_\_\_

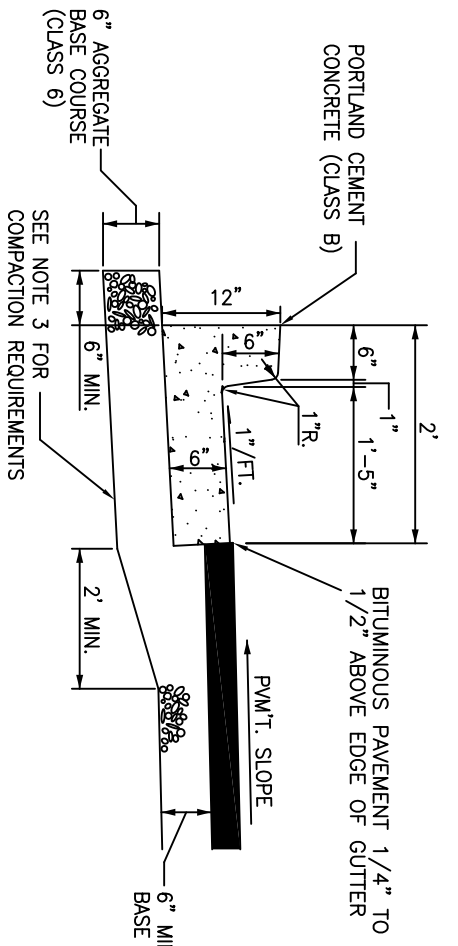

STANDARD CURB & GUTTER

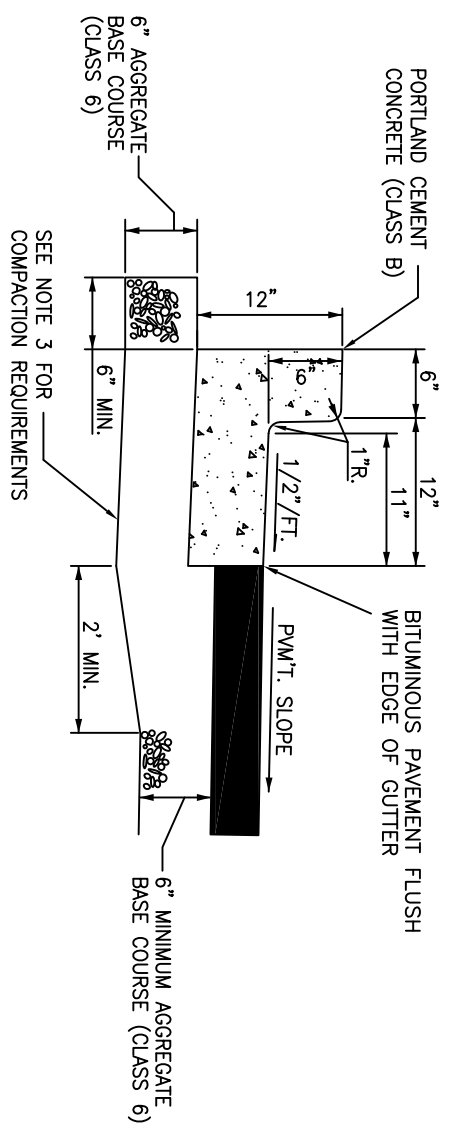

CURB WITH SPILL GUTTER

CITY OF FRUITA  
ENGINEERING DEPARTMENT

SCALE  
HORIZONTAL: N/A  
VERTICAL: N/A

REVISION: 2009 STANDARDS REVISION  
REVISION: \_\_\_\_\_  
REVISION: \_\_\_\_\_

DATE: 3/18/09  
DATE: \_\_\_\_\_  
DATE: \_\_\_\_\_

CURB & GUTTER DETAILS

FILE:  
SHEET: 5.10K

DRAWN BY: CLD  
DATE DRAWN: 5/06  
CHECKED BY: \_\_\_\_\_

DRIVE-OVER CURB & GUTTER

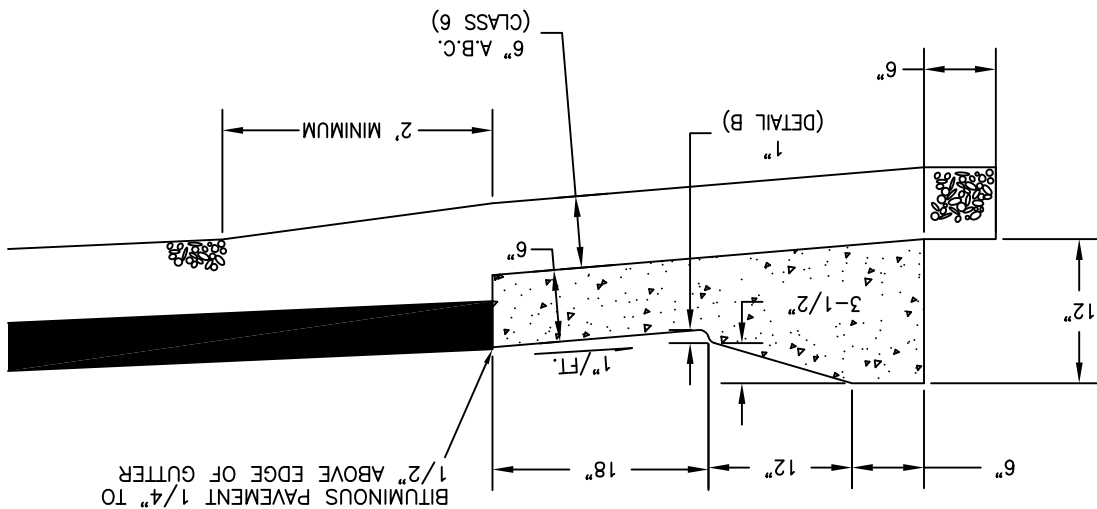

DETAIL "B"

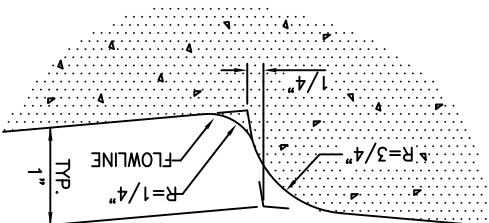

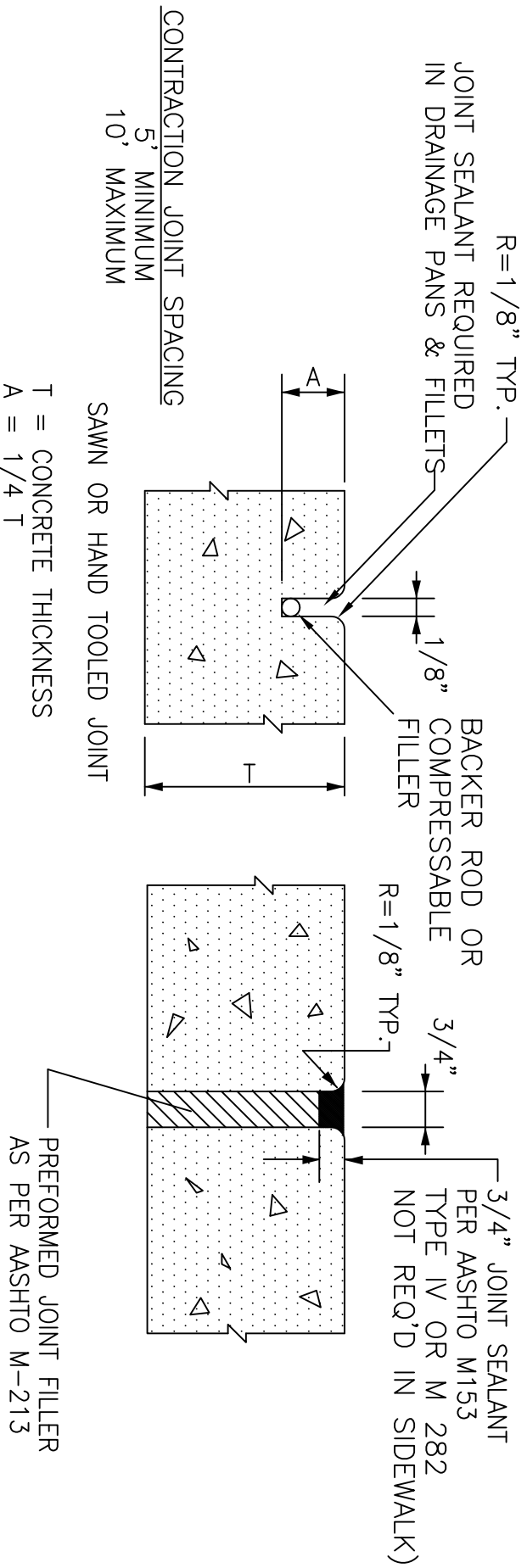

CONTRACTION JOINT

EXPANSION JOINT  
200' MAXIMUM SPACING

CONCRETE JOINT DETAILS

CITY OF FRUITA  
ENGINEERING DEPARTMENT

SCALE  
HORIZONTAL: N/A  
VERTICAL: N/A

REVISION: 2009 STANDARDS REVISION  
REVISION: \_\_\_\_\_  
REVISION: \_\_\_\_\_

DATE: 3/18/09  
DATE: \_\_\_\_\_  
DATE: \_\_\_\_\_

CONCRETE JOINT DETAILS

FILE:  
SHEET: 5.10M

DRAWN BY: CLD  
DATE DRAWN: 5/06  
CHECKED BY: \_\_\_\_\_

MISCELLANEOUS NOTES:

1. THERE ARE MANY FLOW-FILL MIX DESIGNS AVAILABLE FROM LOCAL CONCRETE PRODUCERS THAT REPRESENT A VARIETY OF CONSTRUCTION CONDITIONS. CONSULT WITH THE CITY ENGINEER REGARDING THE CORRECT MIX DESIGN TO USE FOR EACH PROJECT AND EACH SPECIFIC CONDITION. EACH CONTRACTOR IS REQUIRED TO SUBMIT THE SPECIFIC PROPOSED DESIGN MIX TO THE CITY ENGINEER AT THE PRE-CONSTRUCTION MEETING. WRITTEN APPROVAL BY THE CITY ENGINEER IS REQUIRED PRIOR TO COMMENCING WITH THE FLOW-FILL WORK.

PLACEMENT OF FLOWABLE FILL CONCRETE BACKFILL

AFTER ALL PIPE AND APPURTENANCES HAVE BEEN PLACED IN THE TRENCH, BEDDED, AND THE WORK APPROVED IN PLACE, THE TRENCH SHALL BE BACKFILLED WITH FLOW-FILL CONCRETE TO BASE OF SUBGRADE OR PAVEMENT AS SPECIFIED. THE FLOW-FILL CONCRETE SHALL BE RODDED OR VIBRATED AS NECESSARY TO ASSURE VOIDS WILL NOT BE PRESENT IN THE FLOW-FILL CONCRETE OR AROUND OR UNDER PIPE, FITTINGS, AND APPURTENANCES.

PLACEMENT OF BASE COURSE OR PAVING SHALL NOT OCCUR UNTIL THE FLOW-FILL CONCRETE BACKFILL HAS ATTAINED SUFFICIENT STRENGTH TO SUPPORT CONSTRUCTION EQUIPMENT WITHOUT OBSERVABLE DEFORMATION.

CITY OF FRUITA  
ENGINEERING DEPARTMENT

SCALE  
HORIZONTAL: N/A  
VERTICAL: N/A

REVISION: 2009 STANDARDS REVISION      DATE: 3/18/09  
REVISION: \_\_\_\_\_      DATE: \_\_\_\_\_  
REVISION: \_\_\_\_\_      DATE: \_\_\_\_\_

MISCELLANEOUS NOTES

FILE:  
SHEET: 5.10N

DRAWN BY: CLD  
DATE DRAWN: 5/06  
CHECKED BY: \_\_\_\_\_

## Chapter 6

### DRAINAGE AND EROSION CONTROL STANDARDS

#### Sections:

- 6.1: General Provisions
- 6.2: Design Criteria for Drainage Facilities
- 6.3: Detention/Retention Facilities
- 6.4: Construction Materials
- 6.5: Erosion Control Plans
- 6.6: Final Inspection and Acceptance
- 6.7: Storm Water System Details
- 6.8: Storm Water Management Details

#### 6.1: General Provisions

- (A) **General.** The Drainage and Erosion Control Standards are intended to provide for a comprehensive and integrated storm water utility system to convey and manage storm waters in order to mitigate safety hazards and minimize property losses and disruption due to heavy storm runoff and flooding, maintain travel on public streets during storm events, enhance water quality of storm runoff by mitigating erosion, sediment and pollutant transport, control and manage increased runoff due to local development, establish effective long-term management of natural drainageways, and provide for ongoing and emergency maintenance of public storm water systems.
- (B) **Streets.** Streets are an integral part of the local storm water drainage system and may transport local storm runoff as specified in these Standards. However, the primary purpose of streets is for transportation, and storm water conveyance shall not be the major function of a street.

#### 6.2: Design Criteria for Drainage Facilities

- (A) **General.** This section presents the minimum design criteria for the analysis and design of storm drainage facilities. All subdivision, zoning, and other proposed site developments submitted for approval under the provisions of the City Municipal Code shall include adequate storm drainage system analysis and appropriate drainage system design. These are minimum standards. All analysis and design shall meet or exceed these Drainage Standards.

The design guidelines found in the latest version of the Mesa County Stormwater Management Manual (SWMM) shall be used for the design of stormwater facilities in the City of Fruita. Supplemental guidelines are found in Chapter 6.2 (B) of this publication.

Drainage facilities within the City Of Fruita may involve two separate drainage management organizations: the City of Fruita and the Grand Valley Drainage District (GVDD). Storm drainage designs involving joint facilities require the review and approval of both organizations. In particular, any additional inflows into the GVDD system and/or improvements completed on the system require GVDD review and written approval, in addition to review and approval by the City of Fruita.

- (B) **Drainage Report.** All proposed developments within the City of Fruita require a Drainage Report. The Drainage Report shall contain the information and calculations supporting the design of the storm drainage system detailed in the engineering drawings. Such information and calculations shall be presented in a neat and orderly fashion to facilitate review.

The report shall include an analysis of both the immediate area under consideration as well as impacts on downstream facilities. Analyses shall account for the zoning, historical and developed conditions, existing topography and contributing runoff from upstream areas, control easements or features, and continuity with a master plan or with the existing drainage. Natural drainageways are to be used whenever possible. Normally combining irrigation water and storm water is not acceptable. The irrigation company must be contacted for permission to combine these uses.

The report shall contain the hydrologic analysis including areas, storm frequencies, rainfall intensities, runoff coefficients, times of concentration, adjustments for infrequent storms, and all runoff computations. Maps showing the historical and developed basins and sub-basins will accompany the report. A project sub-basin map for subdivisions containing a summary of the point flows and accumulative flows relative to the streets, storm drainage catch basins, and other catchments and release points will accompany the report. This map shall show direction of surface flows and quantity of flows in cfs.

Engineering analyses of all culverts, open channels, and box culverts shall include the design criteria, computations and figures for any detention facility design. The drainage report shall include information relative to soils analysis and water table elevations. All calculations, mass diagrams, and/or hydrographs (methods used will depend on the area of

the basin to be analyzed) required to size the detention facility and determine its discharge shall also be included.

Additionally, the report shall contain analyses and conclusions regarding the effect the additional storm flow created by the development will have on the existing storm system downstream from the new storm flows. Mitigating features necessary to handle the introduction of new storm flows will also be described, and designed, and constructed if determined to be necessary by the City Engineer.

All drainage reports shall include a cover letter indicating the date, the name of the project or subdivision, the engineer or engineers designing the system, and shall be stamped and signed by a licensed professional engineer.

(C) **Pipe Sizing.** Minimum circular pipe inside diameter shall be as follows:

Main storm sewer line	18"
Catch basin lateral	12"
Driveway or other culvert	12"
Rear/side yard systems with area drains	8"
Equivalent sized arch pipe may be used upon written request.	

(D) **Manholes.** Maximum allowable manhole spacing shall be as follows:

<u>Horizontal pipe dimension (inches)</u>	<u>Maximum allowable distance Between Manholes</u>
15 to 30	400'
36 to 60	500'
Larger than 60	750'

Manholes shall be placed wherever there is a change in size, direction, elevation or slope where there is a junction of two or more systems or laterals, or where the maximum distance above is reached.

Interior diameter of all storm sewer manholes shall be as follows:

<u>Horizontal pipe dimension (inches)</u>	<u>Minimum barrel diameter (feet)</u>
15	4
18 to 24	5
30 to 36	6

The City may require a larger barrel sizing should conditions warrant.

(E) **Clearance Distances.** The minimum clearance between storm sewer and water main, either above or below, shall be twelve inches. In all cases, suitable backfill and/or other



protection as deemed necessary by the City Engineer shall be provided to prohibit settling or failure of either pipe system.

The minimum clearance between storm sewer and sanitary sewer, either above or below, shall also be twelve inches. However, when a sanitary sewer main lies above a storm sewer, or within eighteen inches below, the sanitary sewer shall have an impervious encasement or be constructed of structural sewer pipe for a minimum of ten feet on each side of where the storm sewer crosses.

- (F) **Head Wall Requirement.** A concrete head wall at least eight inches thick shall be required at all transitions between culverts and ditches, where the culvert diameter is 24 inches or larger. For smaller diameter pipe, alternate means of protecting culvert ends from vehicles and for channeling runoff into culverts will be reviewed on a case by case basis by the City Engineer.

### 6.3: Detention/Retention Facilities

- (A) **General.** Detention facilities are intended to store increased runoff from developed property and release this runoff at the historic rate that existed prior to development or redevelopment. By providing detention ponding, increased runoff impacts on downstream facilities may be controlled and minimized to reduce potential damages and the need for greatly expanded storm water conveyance facilities.
- (B) **Required.** Detention facilities may be required for the individual development projects. This requirement will be determined by the City Engineer on a case by case situation. Typically detention ponds will not be required for Minor Subdivisions. Minor Subdivisions are 5 or fewer additional lots

Detention facilities that are created for use also as open-space public parks will be designed with a below surface drainage system to avoid standing residual water normally collected in the basin bottom from intermittent rain storms and surface irrigation. Any drain pipes with open ends exposed in the basin area will be screened or grated for safety precautions. The combined detention facility and irrigation facility will not be allowed.

Retention facilities will not typically be allowed unless other alternatives are not available. The allowability of retention facilities will be determined by the City Engineer. A geotechnical evaluation will be mandatory to determine percolation rates of the soil. A combined retention storm water basin and irrigation storage facility will not be allowed.

The design of detention/retention facilities shall follow the SWMM guidelines. Should retention be allowed, the dissipation of the stored run-off will be accomplished as rapidly as possible, but not longer than 48 hours, primarily through the use of below grade infiltration gallery systems. Residual collected run-off in the pond/basin bottom is not acceptable.

- (C) **Maintenance.** The Homeowners Association or individual property owner(s) shall be responsible for maintaining stormwater detention/retention facilities. The City will accept no responsibility for detention/retention facilities, unless specific written arrangements are made with the City and incorporated into the development approval process prior to final approval of the development.

#### 6.4: Construction Materials

- (A) **General.** Construction of storm water-related public improvements shall be in compliance with these Standards. All pipe and structures shall be of adequate strength to support trench and AASHTO HS-20 highway loadings.

- (B) **Piping.** The type of pipe and structures to be installed shall comply with these Standards, and shall be based upon applicable design flows, site conditions and maintenance requirements. Acceptable type of pipe conforming to these standards are the following:

- Reinforced Concrete Pipe (RCP)
- Polyvinyl Chloride (PVC)
- Corrugated High Density Polyethylene or ADS
- Corrugated Metal Pipe (CMP)
- Fusion Welded HDPE

High density polyethylene (HDPE) and fittings less than 24-inch diameter are allowed for general use. Pipe shall be Hancor sur-lok or engineer approved alternative, with smooth interior and water-tight joints. Depending on the depth of bury, flow-fill or concrete encasement may be required for HDPE storm pipe.

All storm drain pipe 24-inch diameter and larger shall be reinforced concrete. Concrete pipe shall be a minimum of Class II and conform to the following ASTM designations. All storm drain pipe located within the public ROW will be RCP, unless otherwise approved by the City.

- Storm drain and sewer pipe, ASTM C-76
- Low-head, ASTM C-361
- Pre-cast manhole sections, ASTM C-478
- Arch pipe, ASTM C-507
- Elliptical pipe, ASTM C-507
- Joints, using rubber gaskets, ASTM C-443

Testing materials to determine compliance with ASTM specifications shall be the responsibility of the contractor. Two certified copies of test results indicating compliance shall be furnished for each lot or shipment prior to installation of the material.

Pipe damaged during shipment or handling will be rejected even if previously approved.

The use of PVC, CMP and Fusion Welded HDPE require written approval by the City.

Flared end sections will normally be used at pipe outfalls.

Rock rip-rap aprons, or an equivalent, will be constructed at the outfall ends of all drain pipes for erosion prevention. Rock rip-rap will be hard, durable and angular (unless contained within wire baskets). Rock size will be determined according to the SWMM requirements.

## **6.5: Erosion Control Plans**

- (A) **General.** All construction activity within the City must address stormwater pollution prevention, and comply with all applicable State of Colorado requirements for pre and post construction storm water management. These are generally known as the “NPDES Phase II Rules”. For construction sites with land disturbance areas 1 acre or larger, the applicant must obtain a CDPS General Permit (NPDES Program) for Stormwater Discharges Associated with Construction Activity. The State requires the application for the above General Permit to be submitted at least 10 days prior to the start of the project. A Stormwater Management Plan (SWMP) must be prepared prior to submittal and Best Management Practices (BMP) in place before construction begins. Please refer to the Colorado Department of Public Health and Environment (CDPHE) website, <http://www.cdphe.state.co.us/wq/PermitsUnit>, for an index to permit documents available on the internet.

The City of Fruita requires a signed copy of the State application in our files before construction begins. The SWMP will be maintained by the Developer/Contractor and must be available for inspection at the job site at all times. In addition, the Construction Drawings set shall include plan sheets showing the Erosion Control Plan and Erosion Control Details for the Development. If required, a written narrative must also be submitted to the City Engineer for review and approval. The narrative report must contain a project description, existing site conditions, and the name of the professional preparing the report.

- (B) **Performance Objectives.** The primary performance objectives of an erosion control plan include:
- (1) Conduct all land disturbance activities in a manner that effectively reduces accelerated soil erosion and reduces sediment transport and offsite deposition.
  - (2) Design and construct all temporary or permanent facilities for the conveyance of water around, through or from the disturbed area to limit the flow of water to non-erosive velocities.
  - (3) Remove sediment caused by accelerated soil erosion from surface runoff water before it leaves the site.
  - (4) Stabilize the areas of land disturbance with permanent vegetative cover or stormwater quality control measures.

Timing of implementation is one of the most critical factors involved in the control of erosion from developing and redeveloping sites.

- (C) **Erosion Control Measures.** There are two types of water erosion control measures; those that prevent initial movement (cover factor, non-structural measures) and those that reduce sediment from moving water (practice factor, structural measures). Erosion control measures must be properly designed, installed **and maintained** if they are to accomplish their intended purpose and effectiveness.
- (1) **Non-structural Erosion Control Measures.** Non-structural erosion control measures provide the best means of managing sediment from disturbed lands by preventing soil movement. Dissipating the kinetic energy of rainfall by placing cover (e.g., straw, burlap, mulch, etc.) over disturbed areas to prevent initial sediment transport.
- One of the more effective practices is the use of vegetation. Vegetative measures can provide temporary cover to help control erosion during construction and permanent cover to stabilize a site after construction is completed. The measures include the use of sod, planting of temporary cover crops and establishing permanent cover crops.
- Two or more different types of seeds must be used and usually with a hydro mulch when establishing a permanent dry land grass cover. It is important to establish vegetative cover as soon as possible in order to reduce erosion. An approved native seed mix design shall be used to reestablish vegetative cover in the City right-of-way. Hydro mulching is essential in establishing good stands of grass on moderate to steep slopes, and on other areas where it is difficult to establish vegetation.
- (2) **Structural Erosion Control Measures.** Once erosion commences due to water, structural measures have to be utilized to reduce sediment transport from disturbed lands. Below are some of the more practical and cost effective measures used in implementing an erosion control plan. These are some of the common structural Best Management Practices for controlling erosion.
- Sediment trap basins
  - Diversions
  - Terraces
  - Berms
  - Surface roughing
  - Filter berms
  - Sediment barriers
  - Straw bales
  - Filtered inlets
  - Contour wind row

Please refer to the Urban Drainage and Flood Control District's *Urban Storm Drainage Criteria* manual, *Volume 3, Construction BMPs* document for generally accepted guidance

on BMP implementation for construction activity. You may access the above document for free at <http://www.udfcd.org>.

## **6.6: Final Inspection and Acceptance**

- (A) **General.** Inspection acceptance of all public storm drain improvements, permanent erosion control measures, and submittal of as-built drawings of the improvements is required PRIOR to issuance of planning clearances for the construction of structures in the development. Inspection of the work shall be by the City.
- (B) **Contractor's Warranty.** The Contractor shall guarantee his work to be free from defects in materials and workmanship for a period of not less than one year. At the end of this 1 year Initial Acceptance period and at the request of the Developer/Contractor the City shall perform a Final Inspection. The City may request such tests and inspections as deemed necessary, consistent with these specifications. Any defects in the system resulting from defective materials, poor workmanship or any other cause attributable to the Developer/Contractor's work shall be corrected to the satisfaction of the City prior to the final release of the subdivision.
- (C) **As-Built Drawings.** Submittal of As-Built construction drawings on 24" x 36" paper or vellum. A licensed Professional Engineer shall certify all As-Built drawings. As-Built drawings shall also be submitted as an electronic AutoCAD file in accordance with the Fruita submittal standards.

## **6.7: Storm Water System Details**

- A. Stormwater Notes**
- B. Storm Sewer Notes**
- C. Standard Manhole Cast-in-place Base**
- D. Shallow Manhole Precast Base**
- E. Storm Drain Inlet w/Curb Opening**
- F. Storm Drain Inlet Drive-over Curb**
- G. Vertical Curb Inlet Installation**
- H. Vertical Curb Inlet Installation (Details)**
- I. Approved Storm Drain Inlet Table**

- J. Standard Cast Iron Manhole Ring and Cover**
- K. Connection to Existing Pipe, Manhole or Inlet Box**
- L. Sidewalk Drain Trough**
- M. Frame and Cover for Sidewalk Drain Trough**

**6.8: Storm Water Management Details**

- A. Silt Fence Notes**
- B. Pre-Fab Silt Fence Installation**
- C. Curb Inlet Filter**
- D. Inlet Protection**
- E. Erosion Bale Notes**
- F. Straw Bales in Drainage Swale**
- G. Installation of Straw Bales**
- H. Erosion Log Applications**
- I. Mulching Notes**
- J. Seeding Notes & Rock Properties**
- K. Crushed Rock Staging Pad**

STORMWATER NOTES:

1. THE CONTRACTOR SHALL NOTIFY GRAND JUNCTION DRAINAGE DISTRICT 24 HOURS PRIOR TO COMMENCING CONSTRUCTION OF THE RESPECTIVE UTILITIES AND ROADWAY (IF APPLICABLE).
2. ALL STORM SEWER CONSTRUCTION SHALL BE IN ACCORDANCE WITH CITY OF FRUITA STANDARDS AND SPECIFICATIONS AND GRAND JUNCTION DRAINAGE DISTRICT STANDARDS AND SPECIFICATIONS, IF APPLICABLE.
3. STEEL FRAMES FOR ALL CURB INLETS AND AREA INLETS SHALL BE GROUTED TO THE CONCRETE BOX.
4. ALL STORM SEWER TRENCH BACKFILL SHALL CONFORM TO THE STANDARD TRENCH DETAIL (SEE STANDARD TRENCH DETAIL). CONTRACTOR SHALL BE REQUIRED TO PERFORM ALL NECESSARY COMPACTION TESTS THROUGH A CERTIFIED SOILS LAB.
5. CONTRACTOR TO VERIFY ALL "TIE-IN" GRADES PRIOR TO ANY CONSTRUCTION.
6. ALL HIGH DENSITY POLYETHYLENE (HDPE) PIPE AND FITTINGS UP TO 24"Ø TO BE THE FOLLOWING:  
HANCOR SURE-LOK OR ENGINEER APPROVED EQUAL.
7. ALL STORM DRAIN PIPE LARGER THAN 24"Ø SHALL BE REINFORCED CONCRETE.  
REINFORCED CONCRETE PIPE SHALL BE A MINIMUM OF CLASS II AND CONFORM TO THE FOLLOWING ASTM DESIGNATIONS:
  - A. STORM DRAIN AND SEWER PIPE, ASTM C-76
  - B. LOW-HEAD, ASTM C361
  - C. PRECAST MANHOLE SECTIONS, ASTM C-478
  - D. ARCH PIPE, ASTM C-507
  - E. ELLIPTICAL PIPE, ASTM C-507
  - F. JOINTS, USING RUBBER GASKETS, ASTM C-443
8. TESTING OF MATERIALS TO DETERMINE COMPLIANCE WITH THE SPECIFICATIONS SHALL BE THE RESPONSIBILITY OF THE CONTRACTOR. TWO CERTIFIED COPIES OF TEST RESULTS INDICATING COMPLIANCE SHALL BE FURNISHED FOR EACH LOT OR SHIPMENT PRIOR TO INSTALLATION OF THE MATERIAL. REINFORCED CONCRETE PIPE SHALL BE TESTED FOR STRENGTH BY THE THREE-EDGE BEARING TEST TO PRODUCE A CRACK OF .01". EACH MANUFACTURER FURNISHING PIPE UNDER THESE SPECIFICATIONS SHALL BE FULLY EQUIPPED TO CARRY OUT THE TESTS DESCRIBED IN ASTM C-497. FAILURE OF ANY PIPE TO MEET THE TEST REQUIREMENTS SHALL BE SUFFICIENT CAUSE FOR REJECTION OF ALL PIPE OF THAT SIZE WHICH THE TEST SPECIMEN REPRESENTS.
9. PIPE DAMAGED DURING SHIPMENT OR HANDLING MAY BE REJECTED EVEN IF PREVIOUSLY APPROVED.
10. AT ALL TIME DURING CONSTRUCTION, EROSION AND SEDIMENT CONTROL SHALL BE MAINTAINED BY THE DEVELOPER OR THEIR DESIGNATED REPRESENTATIVE.
11. EROSION CONTROL SYSTEM SHALL BE INSTALLED AS GRADING PROGRESSES.
12. EROSION BALES SHALL BE STRAW OR HAY, DEPENDING ON AVAILABILITY.
13. EROSION BALES SHALL BE PLACED TO AVOID RUNOFF FLOWING BETWEEN, AROUND OR UNDER BALES. BALES SHALL BE ANCHORED WITH 2"x2"x4' WOODEN STAKES OR #4 REINFORCING BARS, TWO PER BALE (SEE EROSION CONTROL DETAIL SHEET FOR FURTHER INSTRUCTIONS).
14. NEGATIVE IMPACTS TO DOWNSTREAM AREAS (OR RECEIVING WATERS) CAUSED BY THE OVERLOT GRADING TO BE MONITORED AND CORRECTED BY THE DEVELOPER.
15. MULCH SHALL BE APPLIED TO ACHIEVE A STUBBLED SURFACE TO THE DESIGNATED AREAS TO PREVENT DUST AND AID IN LIMITING WIND EROSION. CONTRACTOR SHALL HAVE A WATER TRUCK MADE AVAILABLE TO ASSIST IN CONTROLLING DUST AND WIND EROSION.
16. CONSTRUCTION TRAFFIC ENTRANCES SHALL HAVE AN AGGREGATE STAGING PAD INSTALLED PER EROSION CONTROL DETAILS.
17. DETAILS SHOWN ARE SCHEMATIC ONLY. ADJUST AS NECESSARY TO FIT FIELD CONDITIONS.

CITY OF FRUITA  
ENGINEERING DEPARTMENT

SCALE  
HORIZONTAL: N/A  
VERTICAL: N/A

REVISION: 2009 STANDARDS REVISION DATE: 3/18/09  
REVISION: \_\_\_\_\_ DATE: \_\_\_\_\_  
REVISION: \_\_\_\_\_ DATE: \_\_\_\_\_

STORMWATER NOTES

FILE:  
SHEET: 6.7A

DRAWN BY: CLD  
DATE DRAWN: 5/06  
CHECKED BY: \_\_\_\_\_

STORMWATER NOTES:

1. CONCRETE SHALL CONFORM TO THE CITY OF GRAND JUNCTION SPEC. 601 (STRUCTURAL CONCRETE CLASS B).
2. ANY EXISTING PAVEMENT NOT DESIGNATED FOR REMOVAL WHICH IS DAMAGED BY CONSTRUCTION SHALL BE REPLACED IN-KIND BY THE CONTRACTOR.
3. MANHOLE RISER SECTIONS, CONES, FLAT TOPS, AND GRADE RINGS SHALL BE PRECAST REINFORCED CONCRETE CONFORMING TO ASTM C-478 OR AASHTO M-199.
4. BACKFILL AROUND MANHOLES, INLET BOXES AND OTHER STRUCTURES SHALL BE PLACED IN 8" LIFTS AND COMPACTED TO 95% AASHTO T-99.
5. ALL WORK SHALL BE IN ACCORDANCE WITH APPROVED PLANS AND SPECIFICATIONS.
6. ALL CONCRETE WORK WITHIN PUBLIC RIGHT OF WAY SHALL BE PERFORMED BY A LICENSED CURB, GUTTER AND SIDEWALK CONTRACTOR.
7. MANHOLE STEPS SHALL BE INSTALLED IN VERTICAL ALIGNMENT WITH THE RING AND COVER.
8. ALL CEMENT USED IN MORTAR, CONCRETE BASES, GRADE RINGS, RISER SECTIONS, CONES AND FLAT TOPS FOR STORM SEWER MANHOLES, SHALL BE TYPE V OR MODIFIED TYPE II PORTLAND CEMENT WITH LESS THAN 5% TRICALCIUM ALUMINATE.
9. ALL STORM SEWER MANHOLE LIDS SHALL BE DESIGNATED "STORM SEWER".
10. MANHOLE RING AND COVER CAN BE SET TO FINISHED GRADE, USING NON-SHRINK GROUT TO ADJUST RING ELEVATION. GROUT SHALL NOT EXCEED .15 FT. THICKNESS. GROUT SHALL BE PLACED ONLY UNDER THE CAST IRON RING. NO GROUT SHALL BE PLACED BETWEEN CONCRETE GRADE RINGS.
11. STEEL PAVING RINGS ARE NOT ALLOWED FOR GRADE ADJUSTMENT UNLESS OTHERWISE APPROVED BY THE CITY ENGINEER.
12. SEE "STANDARD TRENCH DETAIL" LOCATED ON GENERAL NOTES DETAIL SHEET FOR TRENCH BACKFILL REQUIREMENTS.

CITY OF FRUITA  
ENGINEERING DEPARTMENT

SCALE  
HORIZONTAL: N/A  
VERTICAL: N/A

REVISION: 2009 STANDARDS REVISION      DATE: 3/18/09  
REVISION: \_\_\_\_\_      DATE: \_\_\_\_\_  
REVISION: \_\_\_\_\_      DATE: \_\_\_\_\_

STORMWATER NOTES

FILE:  
SHEET: 6/7B

DRAWN BY: CLD  
DATE DRAWN: 5/06  
CHECKED BY: \_\_\_\_\_



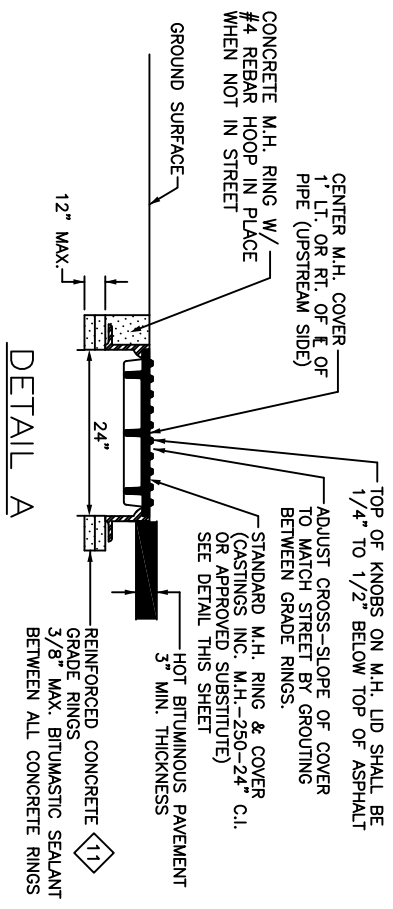
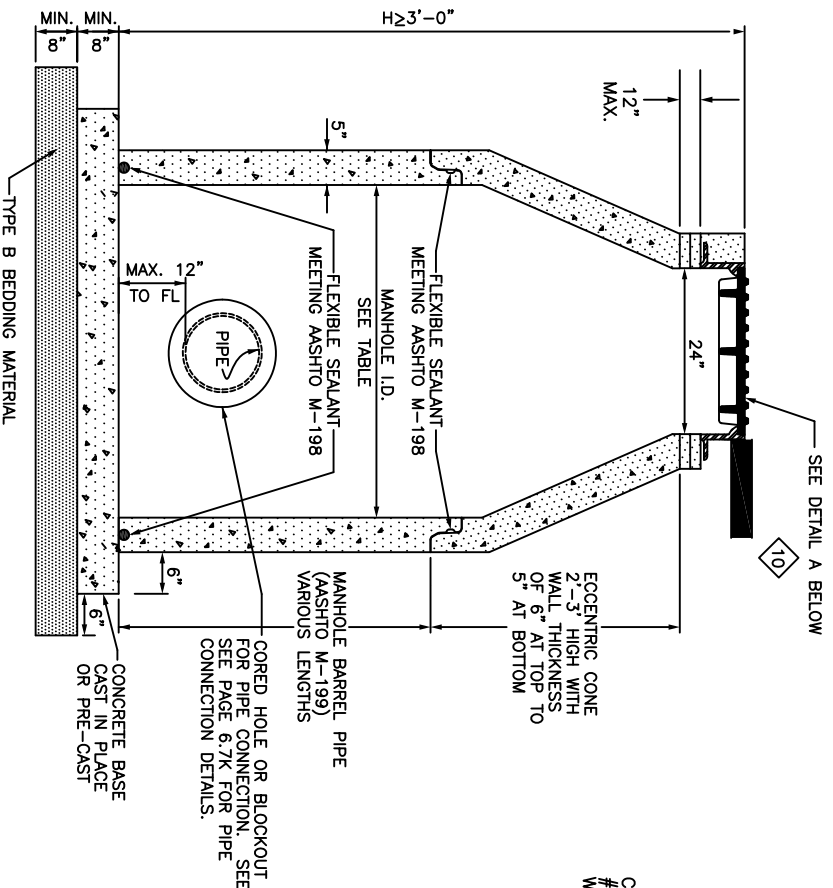

**STANDARD MANHOLE  
CAST-IN-PLACE BASE**

PIPE DIAMETER	MANHOLE I.D.
18" OR LESS	48"
21"-30"	60"
36"	72"
42"-48"	90"

- 10** MANHOLE RING AND COVER CAN BE SET TO FINISHED GRADE, USING NON-SHRINK GROUT TO ADJUST RING ELEVATION. GROUT SHALL NOT EXCEED .15 FT. THICKNESS. GROUT SHALL BE PLACED ONLY UNDER THE CAST IRON RING. NO GROUT SHALL BE PLACED BETWEEN CONCRETE GRADE RINGS.
- 11** STEEL PAVING RINGS ARE NOT ALLOWED FOR GRADE ADJUSTMENT UNLESS OTHERWISE APPROVED BY THE CITY ENGINEER.

ALL PRE-CAST MANHOLE SECTIONS SHALL CONFORM TO ASTM C-478 OR AASHTO M-199. NO STEPS ARE REQUIRED IN STORM SEWER MANHOLES.

CITY OF FRUITA ENGINEERING DEPARTMENT	SCALE HORIZONTAL: N/A VERTICAL: N/A	REVISION: 2009 STANDARDS REVISION REVISION: INCREASED SUMP DEPTH REVISION:	DATE: 3/18/09 DATE: 6/18/09 DATE:
	STANDARD STORM DRAIN MANHOLE	FILE: SHEET: 6.7C	DRAWN BY: CLD DATE DRAWN: 5/06 CHECKED BY:

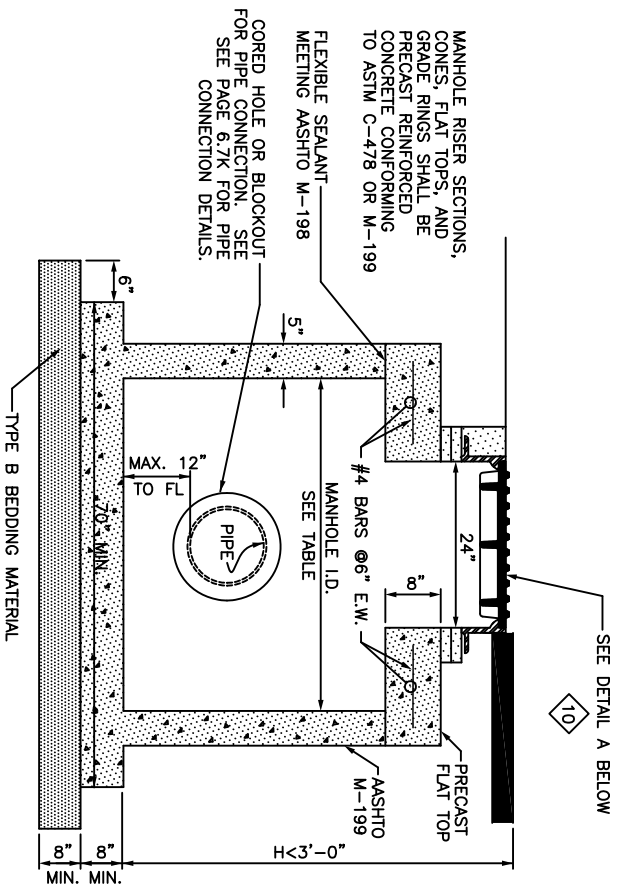

STANDARD SHALLOW MANHOLE  
PRECAST BASE

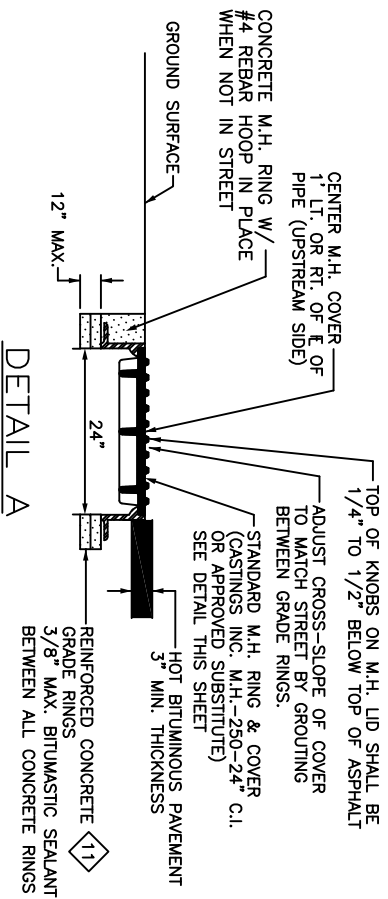

PIPE DIAMETER	MANHOLE I.D.
18" OR LESS	48"
21"-30"	60"
36"	72"
42"-48"	90"

10 MANHOLE RING AND COVER CAN BE SET TO FINISHED GRADE, USING NON-SHRINK GROUT TO ADJUST RING ELEVATION. GROUT SHALL NOT EXCEED .15 FT. THICKNESS  
GROUT SHALL BE PLACED ONLY UNDER THE CAST IRON RING. NO GROUT SHALL BE PLACED BETWEEN CONCRETE GRADE RINGS.

11 STEEL PAVING RINGS ARE NOT ALLOWED FOR GRADE ADJUSTMENT UNLESS OTHERWISE APPROVED BY THE CITY ENGINEER.

ALL PRE-CAST MANHOLE SECTIONS SHALL CONFORM TO ASTM C-478 OR AASHTO M-199. NO STEPS ARE REQUIRED IN STORM SEWER MANHOLES.

CITY OF FRUITA  
ENGINEERING DEPARTMENT

SCALE  
HORIZONTAL: N/A  
VERTICAL: N/A

REVISION: 2009 STANDARDS REVISION  
REVISION: INCREASED SUMP DEPTH  
REVISION:

DATE: 3/18/09  
DATE: 6/18/09  
DATE:

SHALLOW MANHOLE  
PRECAST BASE

FILE:  
SHEET: 6.7D

DRAWN BY: CLD  
DATE DRAWN: 5/06  
CHECKED BY:

# STORM DRAIN INLET WITH CURB OPENING

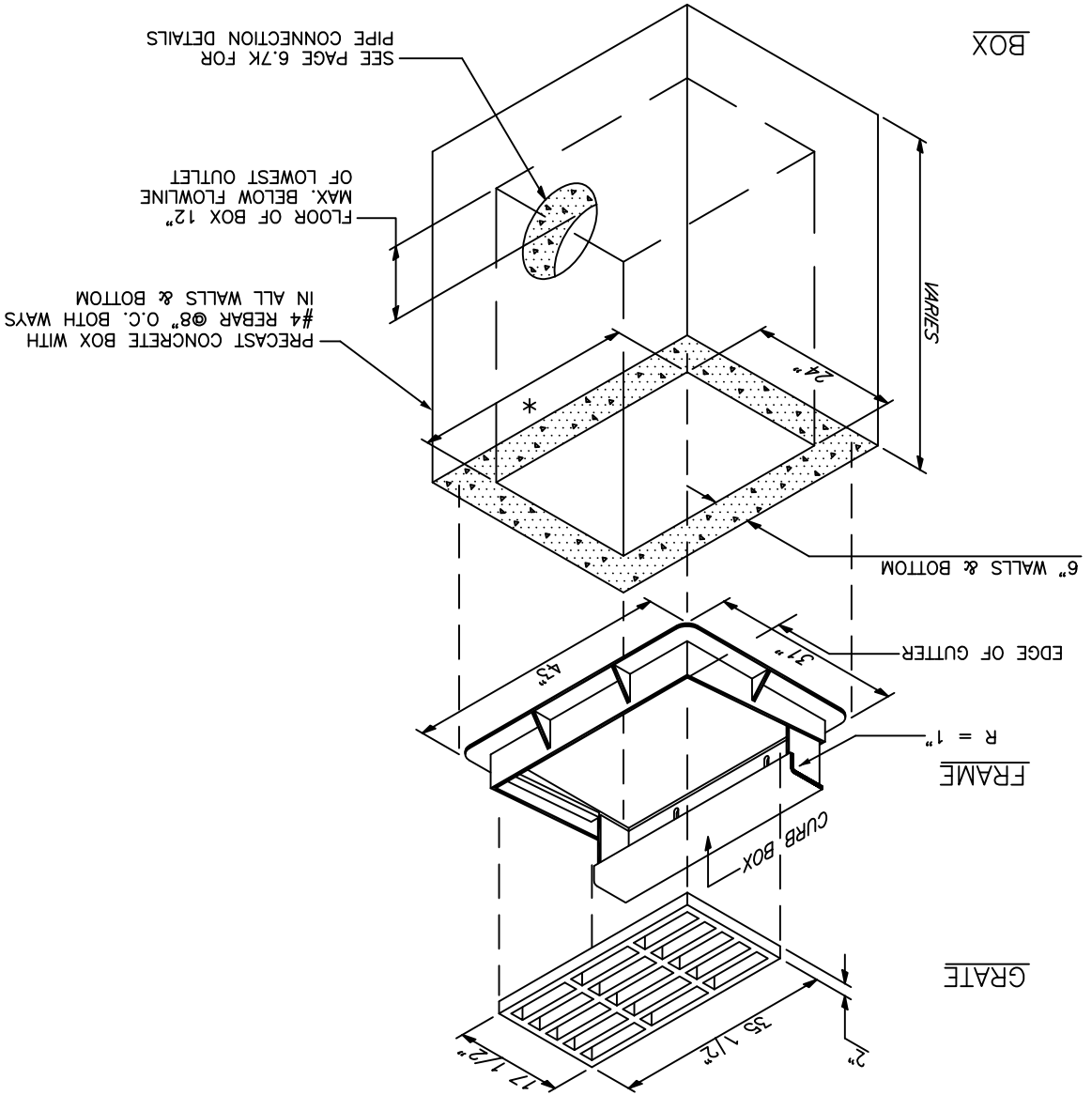

CITY OF FRUITA  
ENGINEERING DEPARTMENT

SCALE  
HORIZONTAL: N/A  
VERTICAL: N/A

REVISION: 2009 STANDARDS REVISION  
REVISION: INCREASED SUMP DEPTH  
REVISION:

DATE: 3/18/09  
DATE: 6/18/09  
DATE:

STORM DRAIN INLET W/ CURB  
OPENING

FILE:  
SHEET: 6.7E

DRAWN BY: CLD  
DATE DRAWN: 5/06  
CHECKED BY:

SECTION D-D

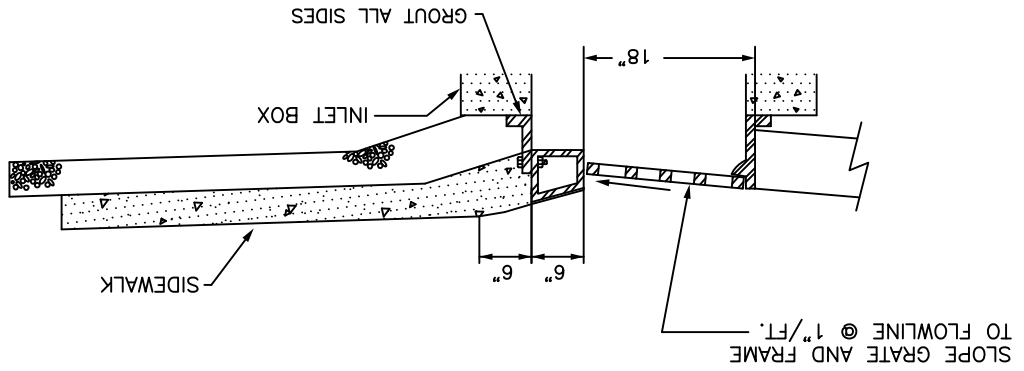

CURB INLET INSTALLATION WITH  
DRIVE-OVER CURB

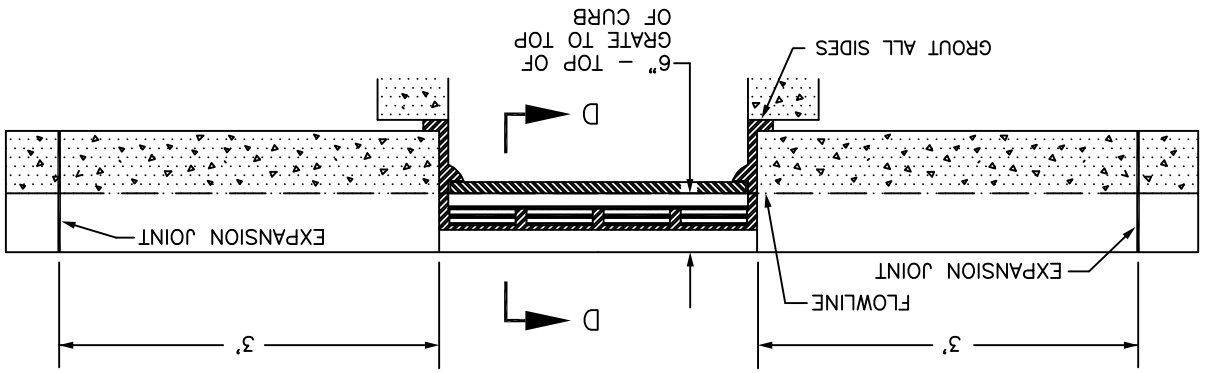

GUTTER INLET DETAIL (DRIVE-OVER CURB)

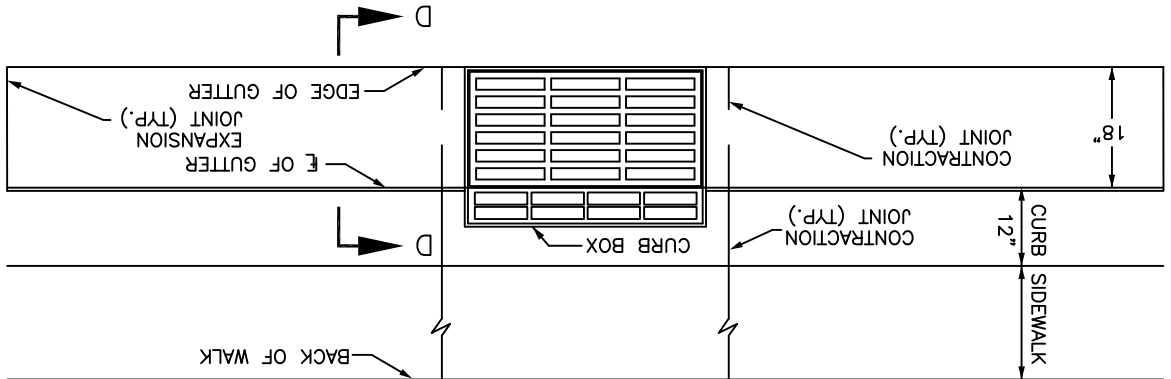

CURB INLET INSTALLATION WITH  
VERTICAL CURB, GUTTER AND SIDEWALK  
ELEVATION VIEW

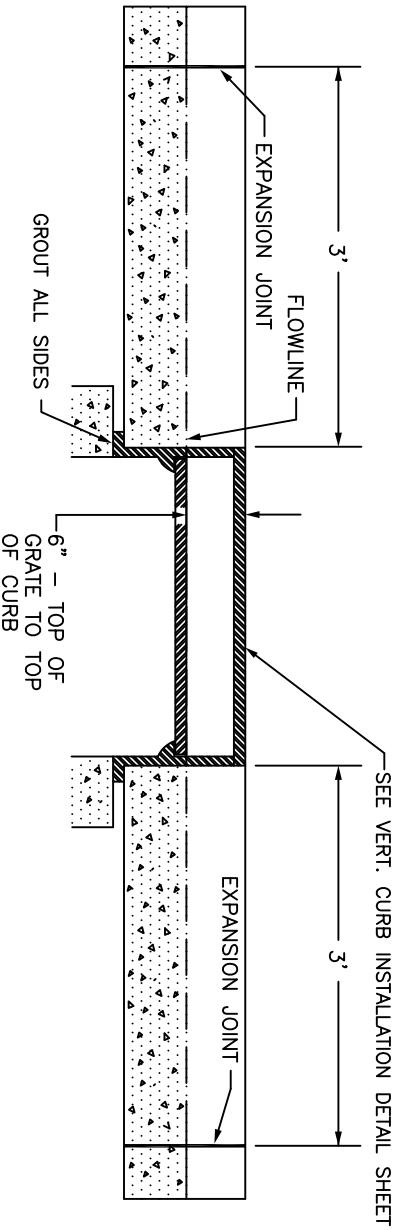

GUTTER INLET DETAIL (VERTICAL CURB)  
PLAN VIEW

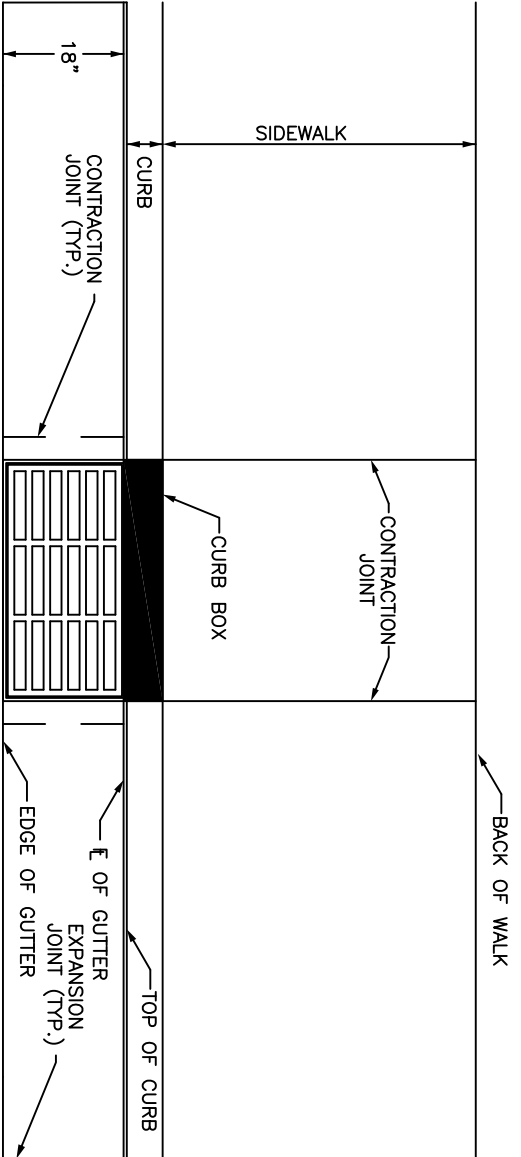

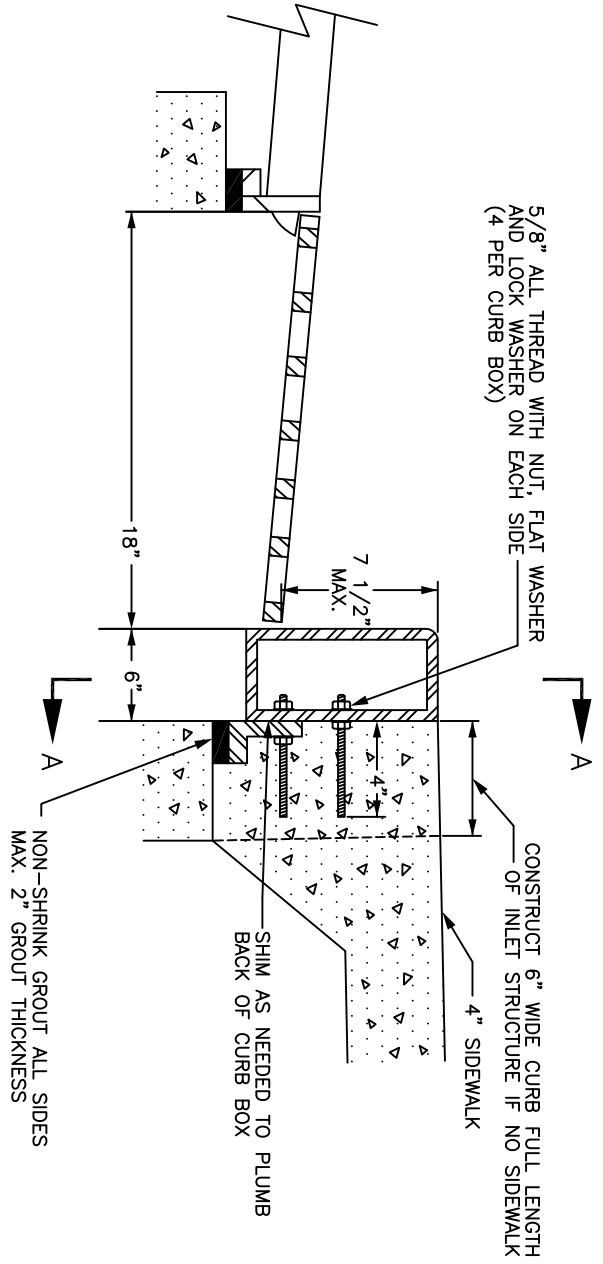

GUTTER INLET DETAIL (VERTICAL CURB)

SIDE VIEW (N.T.S.)

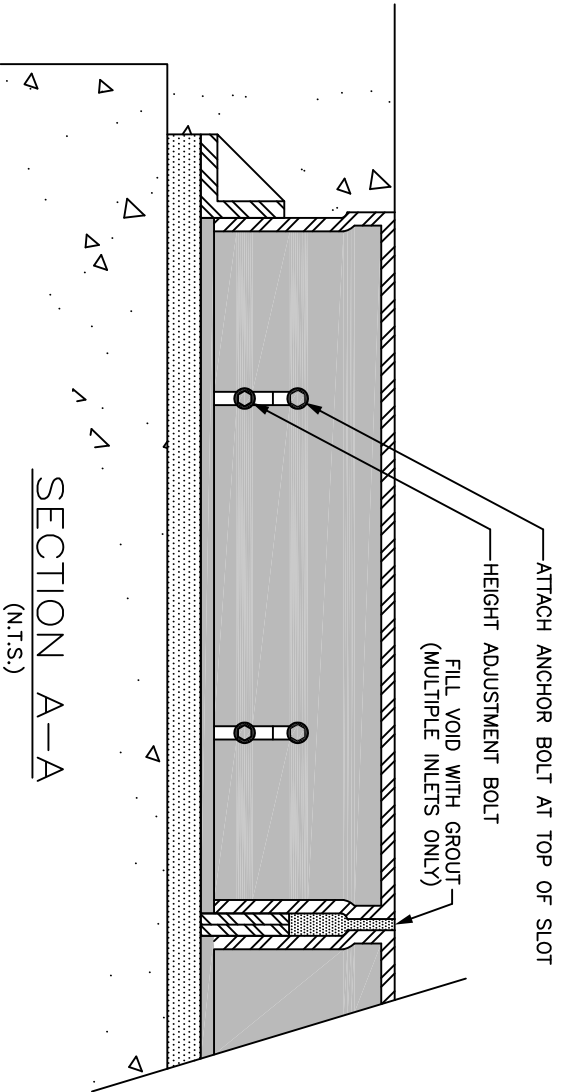

SECTION A-A (N.T.S.)

## APPROVED STORM DRAIN INLETS

TYPE	FRAME	GRATE TYPE	BOX DIM. INSIDE
SINGLE GRATE WITH CURB OPENING	NEENAH R-3246 CASTINGS R-3246	C,DR,DL,L,V C,DR,DL,L,V	24 X 36"
DOUBLE GRATE WITH CURB OPENING	DEETER 2045 NEENAH R-3296 - A	C,DR,DL,L,V C,DR,DL,L,V	24" X 73"
TRIPLE GRATE WITH CURB OPENING	CASTINGS R-3246,DOUBLE DEETER R-2045,DOUBLE NEENAH R-3246-B	C,DR,DL,L,V C,DR,DL,L,V C,DR,DL,L,V	24" X 110"
AREA INLET	CASTINGS R-3246,TRIPLE DEETER 2045,TRIPLE	C,DR,DL,L,V C,DR,DL,L,V	20" X 30"
C.D.O.T. TYPE R	CASTINGS CI-19 X 27 OR CASTINGS NO. 13	C	19 1/2"x35 1/2"
C.D.O.T. TYPE 13	SEE STANDARD M-604-12 SEE STANDARD M-604-13		
SINGLE GRATE W/ DRIVE-OVER CURB	NEENAH IFG 3246DO		

STORM DRAIN INLET GRATES AND FRAMES IN TRAFFIC AREAS SHALL BE BICYCLE SAFE,  
SHALL BE DESIGNED TO WITHSTAND H<sub>2</sub>O LOADING AND SHALL MEET REQUIREMENTS OF AASHTO M105, CLASS 30.

CITY OF FRUITA  
ENGINEERING DEPARTMENT

SCALE  
HORIZONTAL:N/A  
VERTICAL:N/A

REVISION: 2009 STANDARDS REVISION DATE: 3/18/09  
REVISION: \_\_\_\_\_ DATE: \_\_\_\_\_  
REVISION: \_\_\_\_\_ DATE: \_\_\_\_\_

APPROVED STORM DRAIN INLET  
TABLE

FILE:  
SHEET: 6/71

DRAWN BY: CLD  
DATE DRAWN: 5/06  
CHECKED BY: \_\_\_\_\_

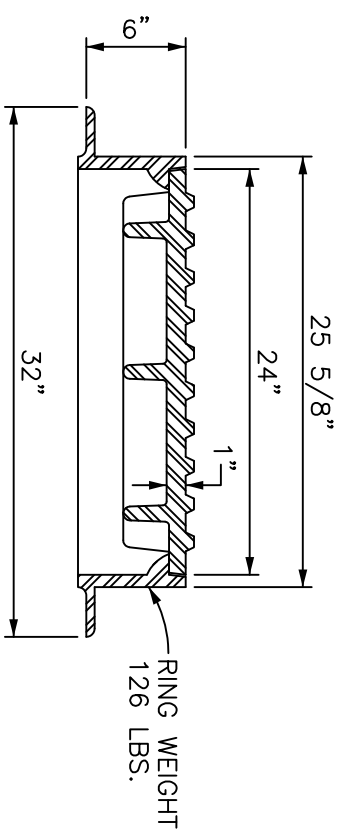
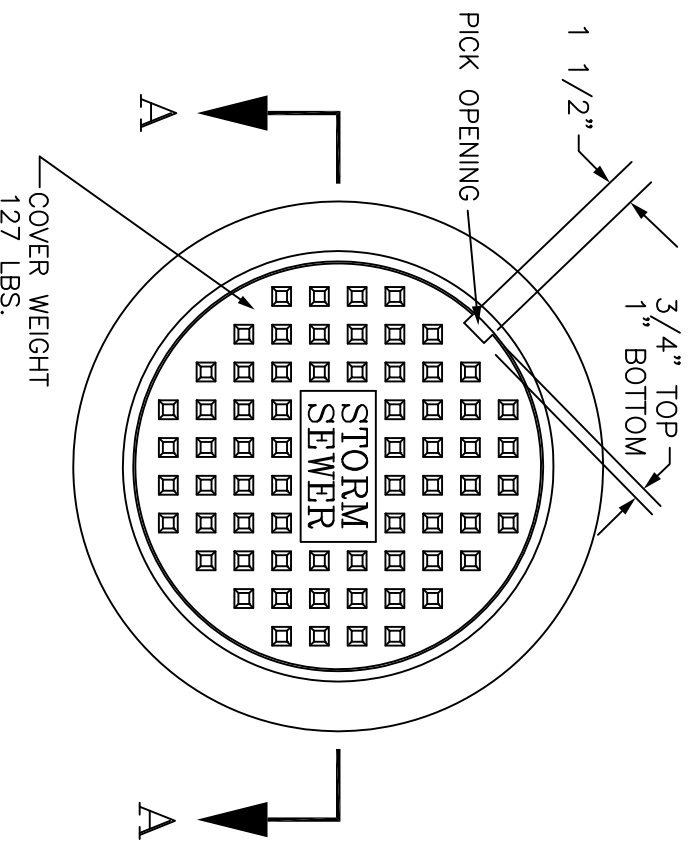

STANDARD CAST IRON  
MANHOLE RING & COVER

CITY OF FRUITA  
ENGINEERING DEPARTMENT

SCALE  
HORIZONTAL: N/A  
VERTICAL: N/A

REVISION: 2009 STANDARDS REVISION  
REVISION: \_\_\_\_\_  
REVISION: \_\_\_\_\_

DATE: 3/18/09  
DATE: \_\_\_\_\_  
DATE: \_\_\_\_\_

STANDARD CAST IRON  
MANHOLE RING & COVER

FILE:  
SHEET: 6.7J

DRAWN BY: CLD  
DATE DRAWN: 5/06  
CHECKED BY: \_\_\_\_\_



# PVC PIPE CONNECTION

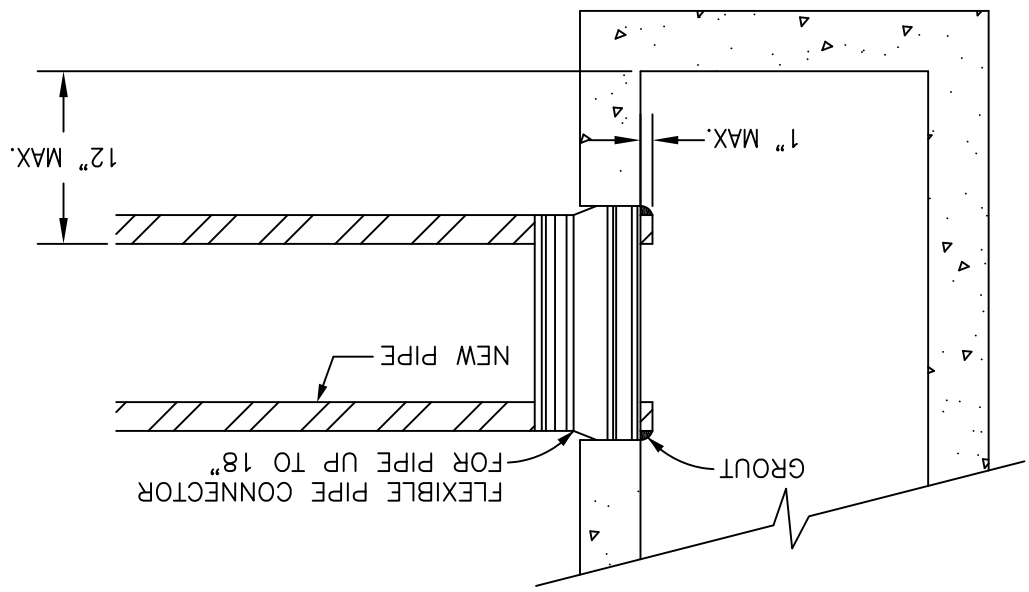

(FOR CONNECTIONS TO EXISTING STRUCTURES)

# GROUTED PIPE CONNECTION

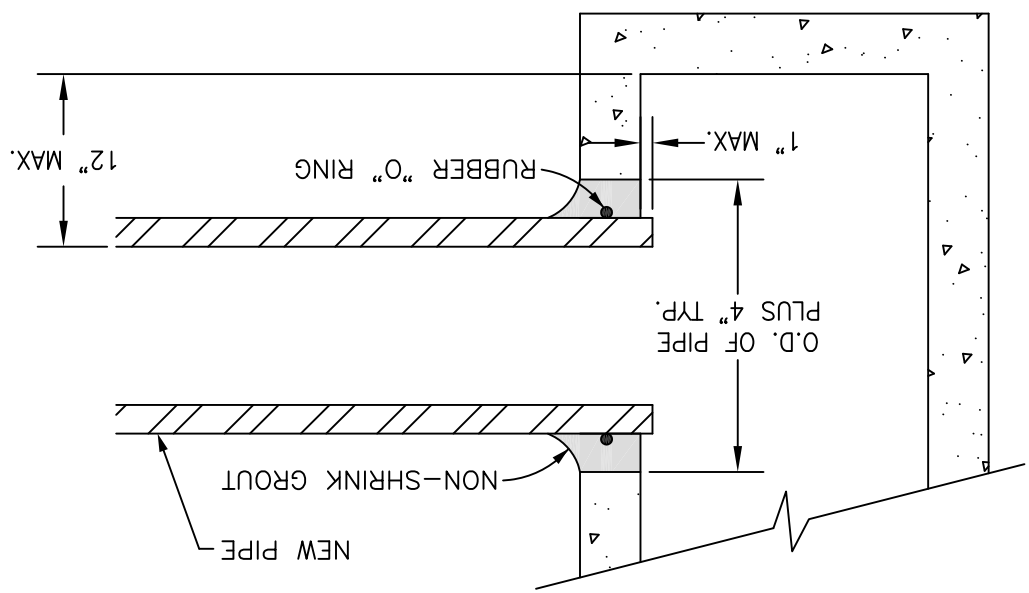

CITY OF FRUITA  
ENGINEERING DEPARTMENT

SCALE  
HORIZONTAL: N/A  
VERTICAL: N/A

REVISION: 2009 STANDARDS REVISION  
REVISION: COF REVISIONS  
REVISION:

DATE: 3/18/09  
DATE: 6/18/09  
DATE:

CONNECTION TO EXST. PIPE,  
MANHOLE OR INLET BOX

FILE:  
SHEET: 6.7K

DRAWN BY: CLD  
DATE DRAWN: 5/06  
CHECKED BY:

NOTE: PRE-MANUFACTURED DRAIN TROUGHS MAY BE SUBSTITUTED FOR THIS DETAIL WHEN APPROVED BY THE CITY ENGINEER.

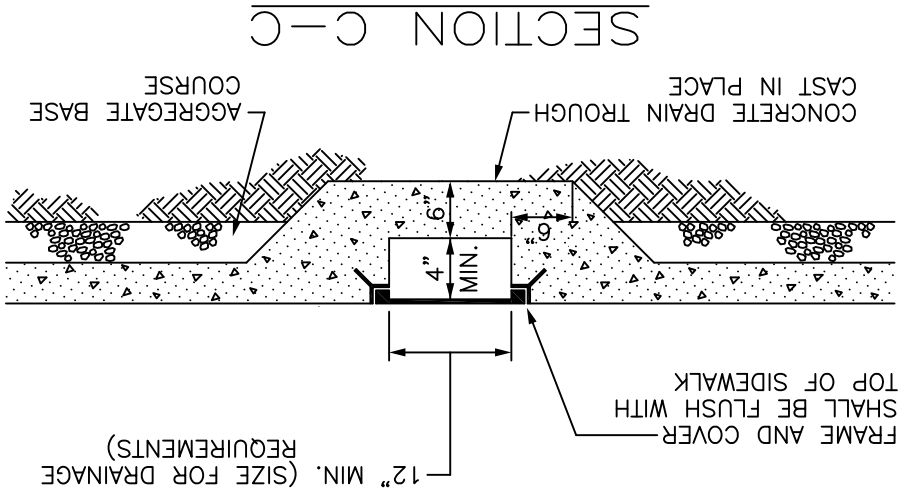

NOTE: FRAME AND COVER SHALL BE FABRICATED OF SAME MATERIAL (STEEL OR ALUMINUM). ALL STEEL SURFACES SHALL BE GALVANIZED PER AASHTO M-111. DIRECTION OF FLOW SHALL BE FROM PROPERTY TO STREET ONLY. WHEN THE RUNOFF RATE EXCEEDS THE DRAIN TROUGH CAPACITY, OTHER APPROVED CONVEYANCE METHODS/FACILITIES SHALL BE UTILIZED.

DRAIN TROUGH  
FOR SIDEWALK CROSSING

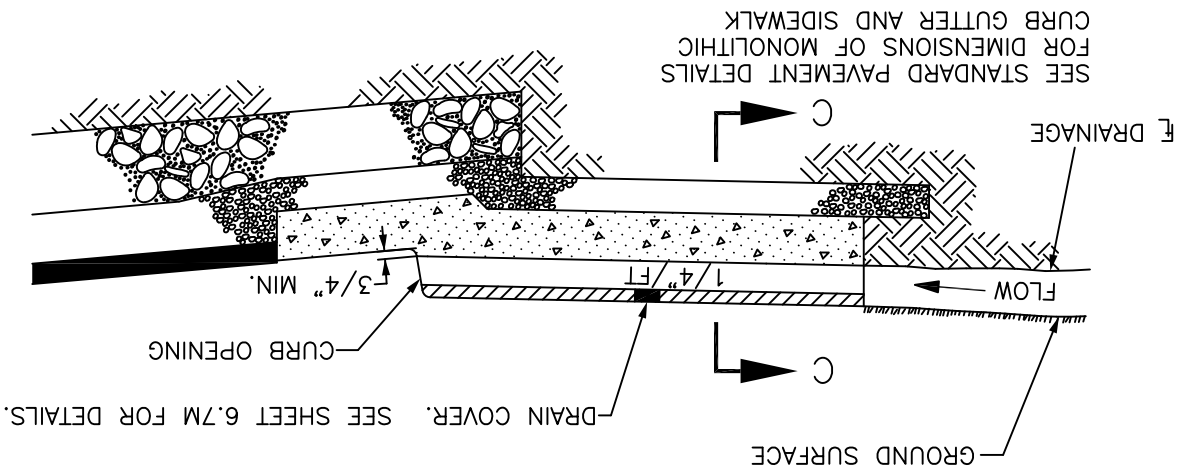

DRAIN COVER. SEE SHEET 6.7M FOR DETAILS.

SEE STANDARD PAVEMENT DETAILS FOR DIMENSIONS OF MONOLITHIC CURB GUTTER AND SIDEWALK

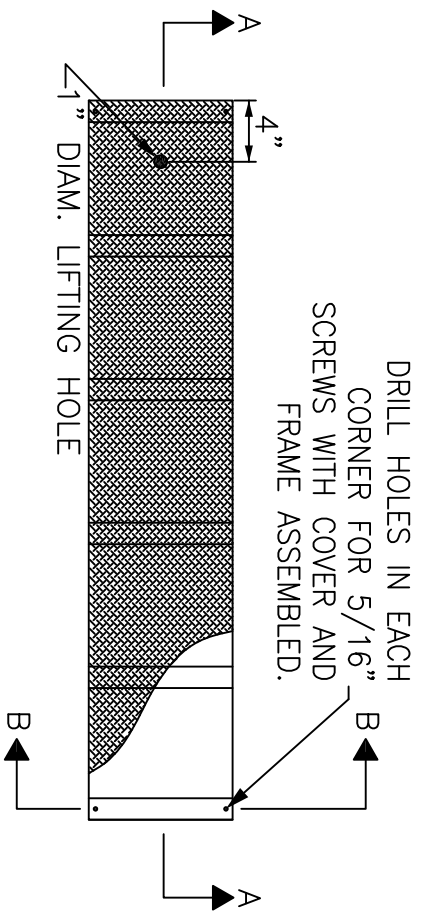

COVER PLAN VIEW

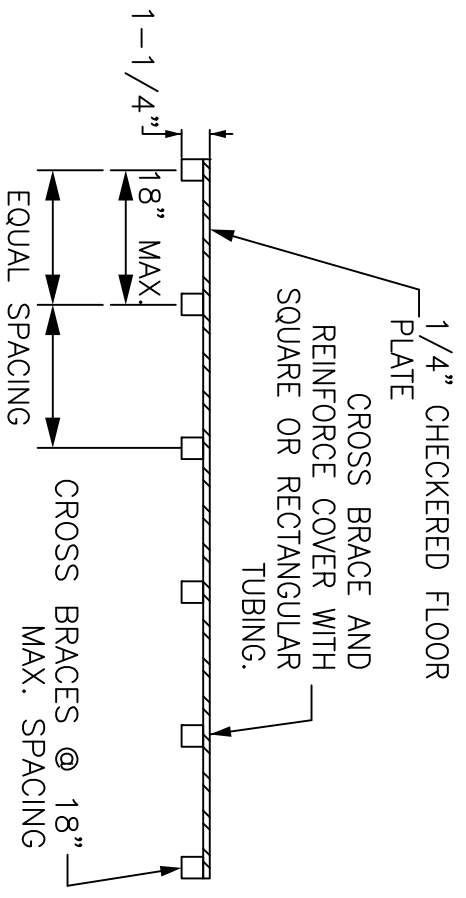

COVER SECTION A-A

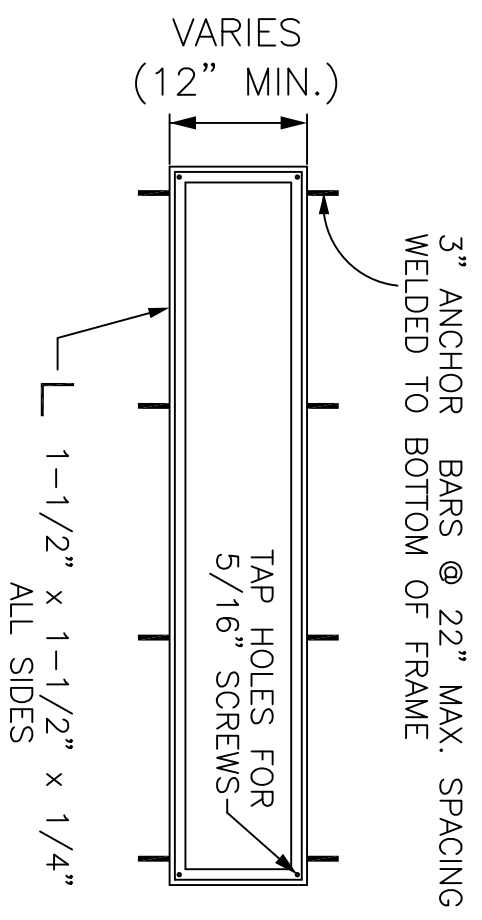

FRAME PLAN VIEW

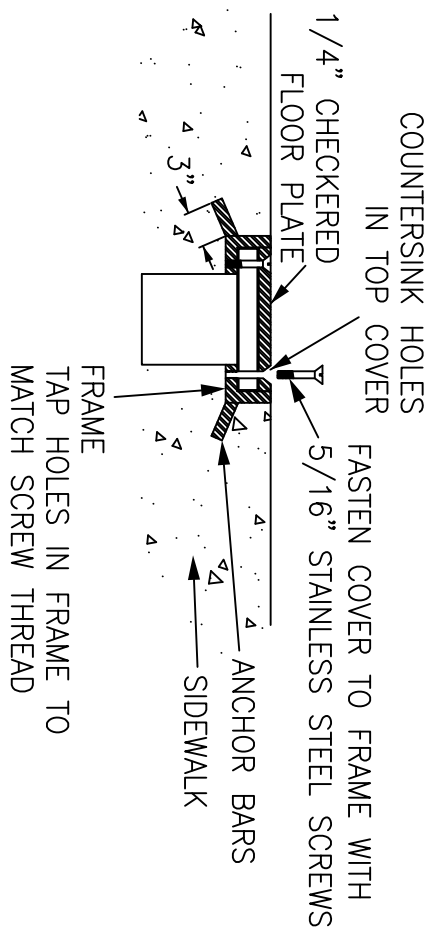

SECTION B-B

CITY OF FRUITA  
ENGINEERING DEPARTMENT

SCALE  
HORIZONTAL: N/A  
VERTICAL: N/A

REVISION: 2009 STANDARDS REVISION  
REVISION: \_\_\_\_\_  
REVISION: \_\_\_\_\_

DATE: 3/18/09  
DATE: \_\_\_\_\_  
DATE: \_\_\_\_\_

FRAME AND COVER FOR  
SIDEWALK DRAIN THROUGH

FILE:  
SHEET: 6.7M

DRAWN BY: CLD  
DATE DRAWN: 5/06  
CHECKED BY: \_\_\_\_\_

## Silt Fence

A temporary vertical barrier of filter fabric attached and supported by posts and entrenched to the ground.

### I. Application

Used to intercept and detain small amounts of sediment from disturbed areas during construction operations to prevent sediment from leaving the site.

Used to decrease the velocity of sheet flows and low-to-moderate level channel flows.

Typically used along the toe of fills, in transition areas between cut and fills, adjacent to streams and along private property.

Also used around median and yard inlets as applicable, and behind curb and gutter to prevent siltng of the pavement.

### II. Use Limitations

Where the size of the drainage areas is no more than 1/4 acre per 100 feet of silt fence length; the maximum slope length behind the barrier is 100 feet; and the maximum gradient behind the barrier is 50% (2:1).

On steep slopes care should be given to placing alignment of fence perpendicular to the general direction of the flow, keying in the filter fabric.

Should not be used in areas where rocky soils will prevent

### Materials

The synthetic filter fabric shall conform to the requirements described in CDOT's Standard Specifications for Road and Bridge Construction.

The Synthetic filter fabric shall contain ultraviolet ray inhibitors and stabilizers to provide a minimum of 6 months of expected usable construction life at a temperature range of 0 to 120 degrees F.

If a burllap is used, it shall be purchased in a continuous roll and cut to the length of the barrier to avoid than use of joints and thus improve the strength and efficiency of the barrier.

Posts for silt fences shall be metal or hardwood with a minimum length of 42 inches. Pine wood shall not be used. Wood posts shall have a minimum diameter of cross section of 1.25 inches. Metal posts shall be "studded tee" or "U" type with minimum weight of 1.33 lbs/lin. ft., and they shall be protected against corrosion. Metal posts should also have projections for fastening wire to them.

Wire fence reinforcement for silt fences using standard strength filter cloth shall be a minimum of 42 inches in height, a minimum of 14 gauge and shall have a maximum mesh spacing of 6 inches.

### Installation

Silt fences must be located along a terrain contour and the area below the fence must be undisturbed or stabilized.

The posts shall be driven vertically into the ground to a minimum depth of 6 inches.

A trench shall be excavated approximately 4 inches wide and 4 inches deep along the line of posts and upslope from the barrier; the bottom 8" of the filter fabric shall be buried into this trench.

The trench shall be backfilled and the soil compacted.

The filter materials shall be fastened securely to metal or wood posts using wire ties, or to the wood posts with 3/4 inches long #9 heavy duty staples. Filter material shall not be stapled to existing trees.

If a filter barrier is to be constructed across a ditch line or swale, the barrier shall be of sufficient length to eliminate end flow, and the plan configuration shall resemble an arc or horseshoe with the ends oriented upslope.

When joints are necessary, filter cloth shall be spliced together only at a support post, with a minimum 6-inch overlap, and securely sealed.

When standard strength filter fabric is used, a wire mesh support fence shall be fastened securely to the upslope side of the posts using heavy duty wire staples at least 3/4 inch long, the wires or hog rings. The wire shall extend into the trench a minimum of 2 inches and shall not extend more than 36 inches above the original ground surface.

When extra strength filter fabric and closer post spacing are used, the wire mesh support fence may be eliminated. In such a case, the filter fabric is stapled or wired directly to the posts with all other provisions of the above item applying.

Silt fences shall be periodically maintained to prevent sediment from passing over or under the fence. Sediments shall be removed from behind the silt fence when it accumulates to one-half the exposed fabric height.

Filter barriers shall be removed when they have served their useful purpose, but not before the upslope area has been permanently stabilized.

### Sheet Flow Applications

The height of the silt fence shall be minimum 22 inches and shall not exceed 36 inches; higher fences may impound volumes of water sufficient to cause failure of the structure.

Posts shall be spaced a maximum of 10 feet apart. If an extra strength filter fabric without the wire support fence is used, maximum space shall not exceed 6 feet.

### Channel Flow Applications

The height of the silt fence shall be a minimum of 15 inches and shall not exceed 18 inches.

Posts shall be spaced a maximum of 3 feet apart.

CITY OF FRUITA  
ENGINEERING DEPARTMENT

SCALE  
HORIZONTAL: N/A  
VERTICAL: N/A

REVISION: 2009 STANDARDS REVISION  
REVISION: \_\_\_\_\_  
REVISION: \_\_\_\_\_

DATE: 3/18/09  
DATE: \_\_\_\_\_  
DATE: \_\_\_\_\_

SILT FENCE NOTES

FILE:  
SHEET: 6.8A

DRAWN BY: CLD  
DATE DRAWN: 5/06  
CHECKED BY: \_\_\_\_\_

# INSTALLING A PREFAB SILT FENCE

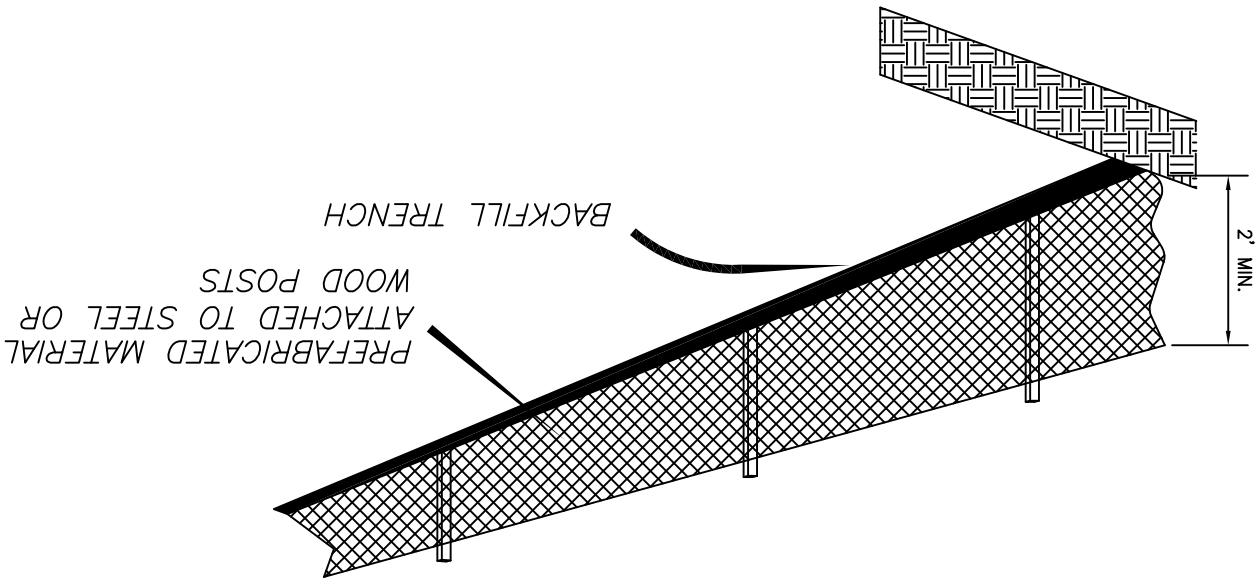
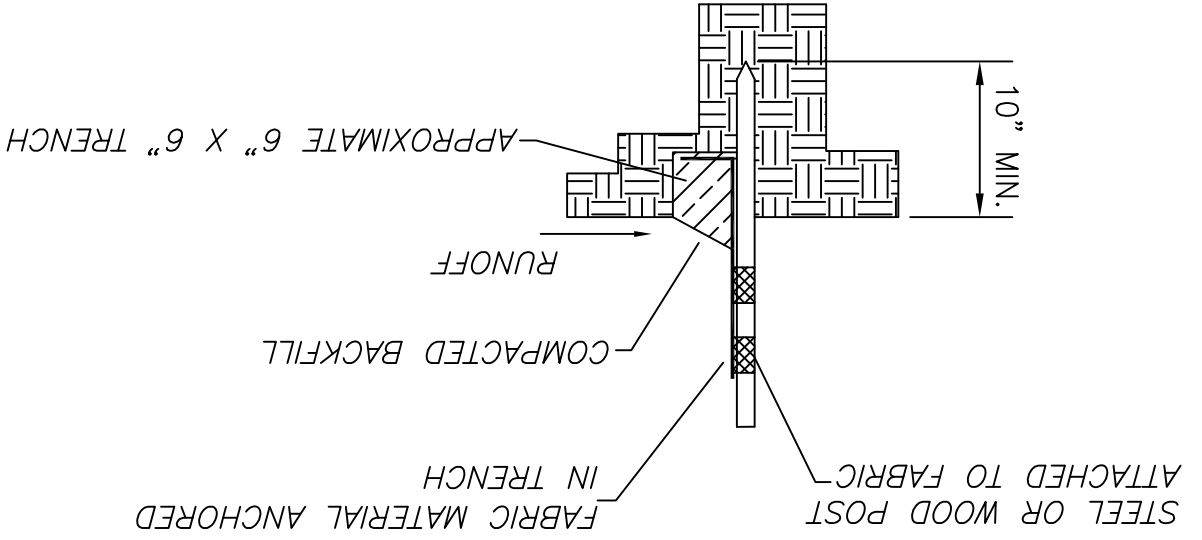

CITY OF FRUITA  
ENGINEERING DEPARTMENT

SCALE  
HORIZONTAL: N/A  
VERTICAL: N/A

REVISION: 2009 STANDARDS REVISION  
REVISION: \_\_\_\_\_  
REVISION: \_\_\_\_\_

DATE: 3/18/09  
DATE: \_\_\_\_\_  
DATE: \_\_\_\_\_

PRE-FAB SILT FENCE  
INSTALLATION

FILE:  
SHEET: 6.88

DRAWN BY: CLD  
DATE DRAWN: 5/06  
CHECKED BY: \_\_\_\_\_

- Curb Inlet Filter**
1. Install immediately after curb inlet box and frame are placed.
  2. To remain in place until street paving is completed.

**CURB INLET FILTER (N.T.S.)**

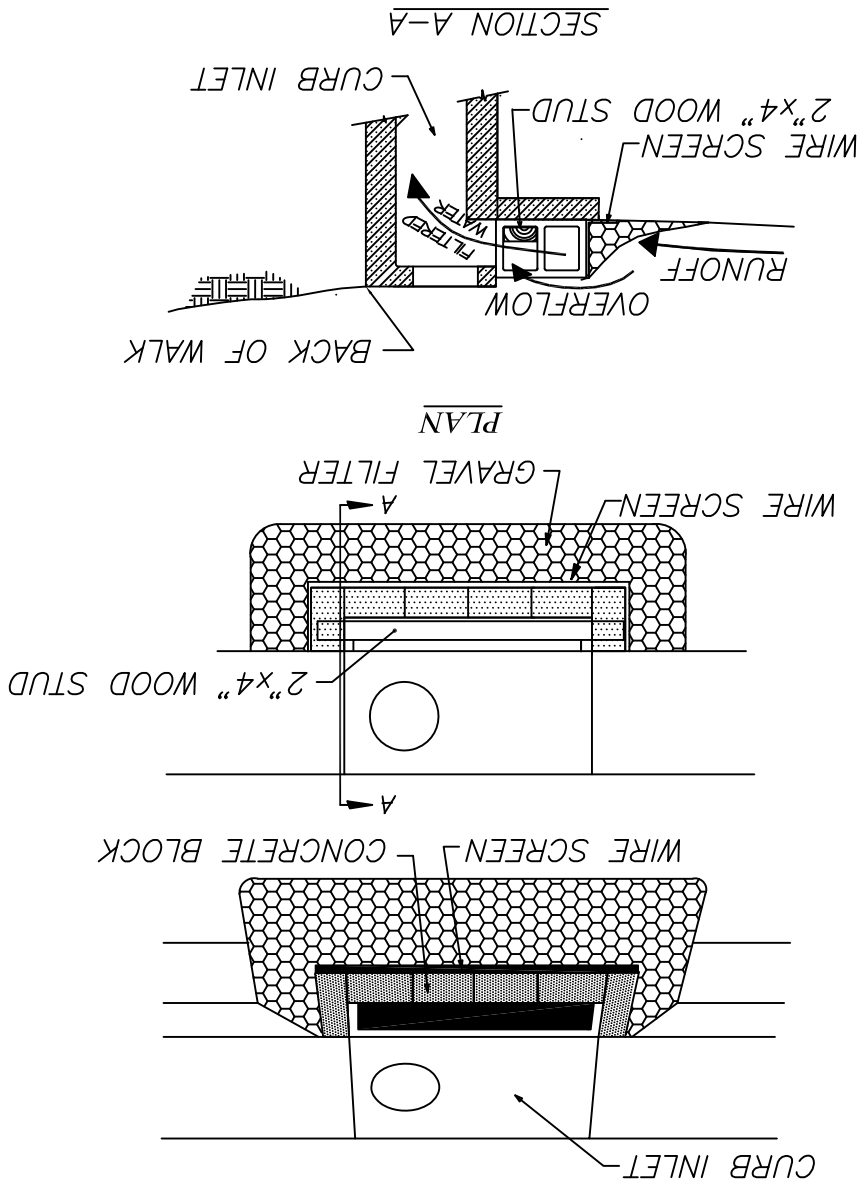

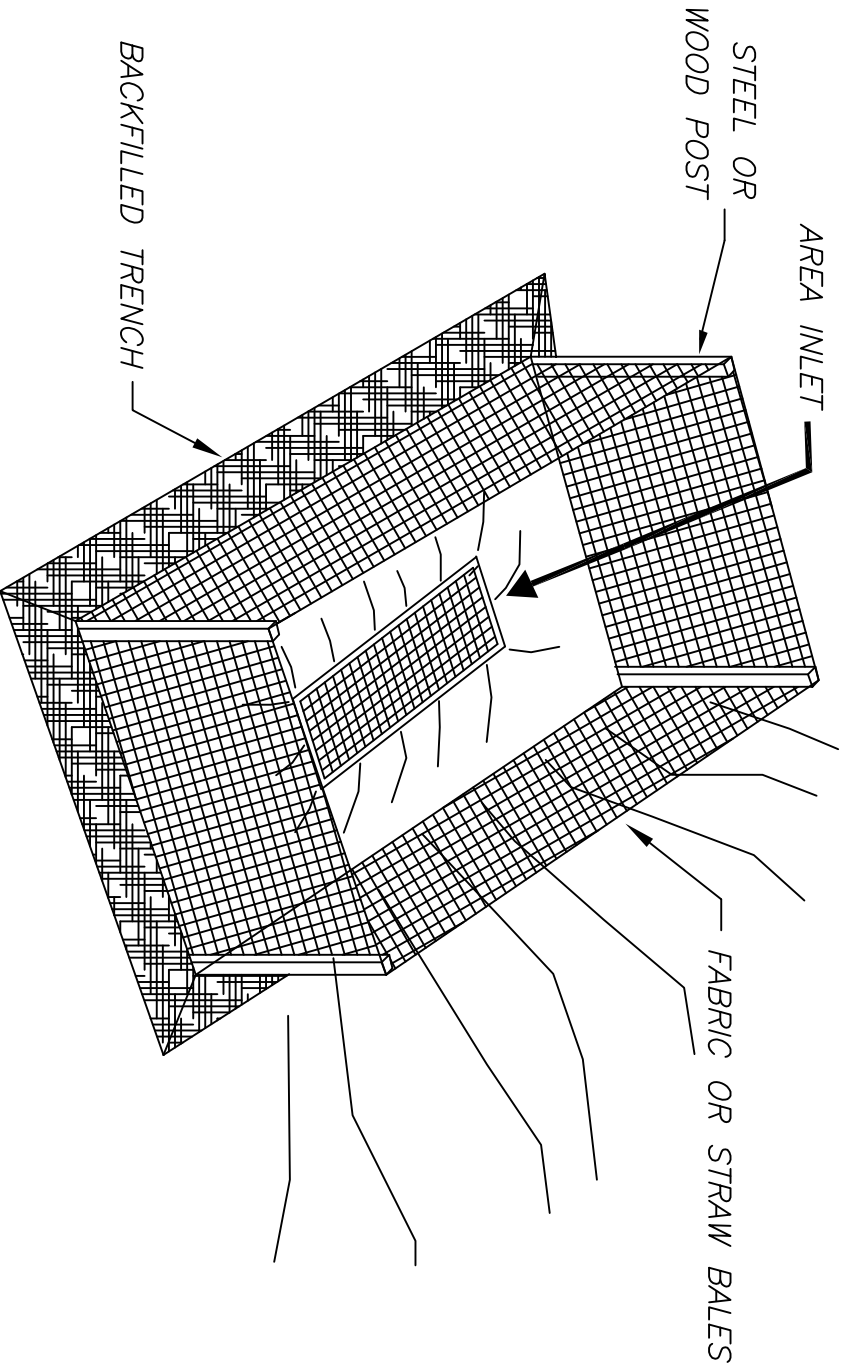

INLET PROTECTION (N.T.S.)

CITY OF FRUITA  
ENGINEERING DEPARTMENT

SCALE  
HORIZONTAL: N/A  
VERTICAL: N/A

REVISION: 2009 STANDARDS REVISION  
REVISION: \_\_\_\_\_  
REVISION: \_\_\_\_\_

DATE: 3/18/09  
DATE: \_\_\_\_\_  
DATE: \_\_\_\_\_

INLET PROTECTION

FILE:  
SHEET: 6.80

DRAWN BY: CLD  
DATE DRAWN: 5/06  
CHECKED BY: \_\_\_\_\_

### Erosion Bale

A temporary sediment barrier consisting of a row of entrenched and anchored straw, or hay bales.

#### I. Application

Use as filters along the toe of fills.

Use as erosion checks in ditches.

Use for diversions and filters in unfinished drop inlets, culvert inlets, and outlets.

#### II. Use Limitations

Do not use if size of the drainage area is greater than 1/4 acre per 100 feet of barrier length.

Maximum slope length behind the barrier is 100 feet.

Maximum slope gradient behind the barrier is 50%.

In minor swales or ditch lines where the maximum contributing drainage area is no greater than one acre.

Where effectiveness is required for less than 3 months.

Under no circumstances should erosion bale barriers be constructed in active streams or in swales where there is the possibility of a washout.

Should be used only in areas of sheet flow or very low flow.

Not to be used where the control of sediment is critical or in high risk areas.

Not to be used where it cannot be entrenched as required and firmly anchored. Useful life of erosion bale barriers is relatively short; the barrier may have to be replaced one or more times during construction.

#### III. Construction Guidelines

All bales shall be either wire-bound or string-tied. Erosion bales shall be installed so that bindings are oriented around the sides rather than along the tops and bottoms of the bales (in order to prevent deterioration of bindings).

The barrier shall be entrenched and backfilled. A trench shall be excavated the width of a bale and the length of the proposed barrier to a minimum depth of 4 inches. After the bales are staked, the excavated soil shall be backfilled against the barrier. Backfill soil shall conform to the ground level on the downhill side and shall be built up to 4 inches against the uphill side of the barrier.

Each base shall be securely anchored by at least two 2"x2" stakes or #4 rebar driven toward the previously laid bale to force the bales together. Stakes or rebar shall be driven 6 inches minimum into the ground to securely anchor the bales.

The gaps between bales shall be filled by wedging with straw to prevent water from escaping between the bales. The main consideration is to obtain tight joints. Erosion bales will not filter sediment out of the water if the water is allowed to flow between, around, or under the bales. Loose straw or hay scattered over the area immediately uphill from an erosion bale barrier tends to increase barrier efficiency.

Since erosion bales deteriorate quickly, the inspection during construction shall be frequent and repair or replacement shall be made promptly as needed.

Erosion bales shall be removed when they have served their usefulness, but not before the upslope areas have been permanently stabilized.

Trenches where erosion bales were located shall be graded and stabilized.

#### Sheet Flow Applications

Bales shall be placed in a single row, lengthwise on the contour with ends of adjacent bales tightly abutting.

#### Channel Flow Applications

Bales shall be placed in a single row, lengthwise, oriented perpendicular to the contour, with ends of adjacent bales tightly abutting one another.

The barrier shall be extended to such a length that the bottoms of the end bales are higher in elevation than the top of the lowest middle bale to assure that sediment-laden runoff will flow either through or over the barrier but not around it. Silt Fence

CITY OF FRUITA  
ENGINEERING DEPARTMENT

SCALE  
HORIZONTAL: N/A  
VERTICAL: N/A

REVISION: 2009 STANDARDS REVISION  
REVISION: \_\_\_\_\_  
REVISION: \_\_\_\_\_

DATE: 3/18/09  
DATE: \_\_\_\_\_  
DATE: \_\_\_\_\_

EROSION BALE NOTES

FILE:  
SHEET: 6.8E

DRAWN BY: CLD  
DATE DRAWN: 5/06  
CHECKED BY: \_\_\_\_\_



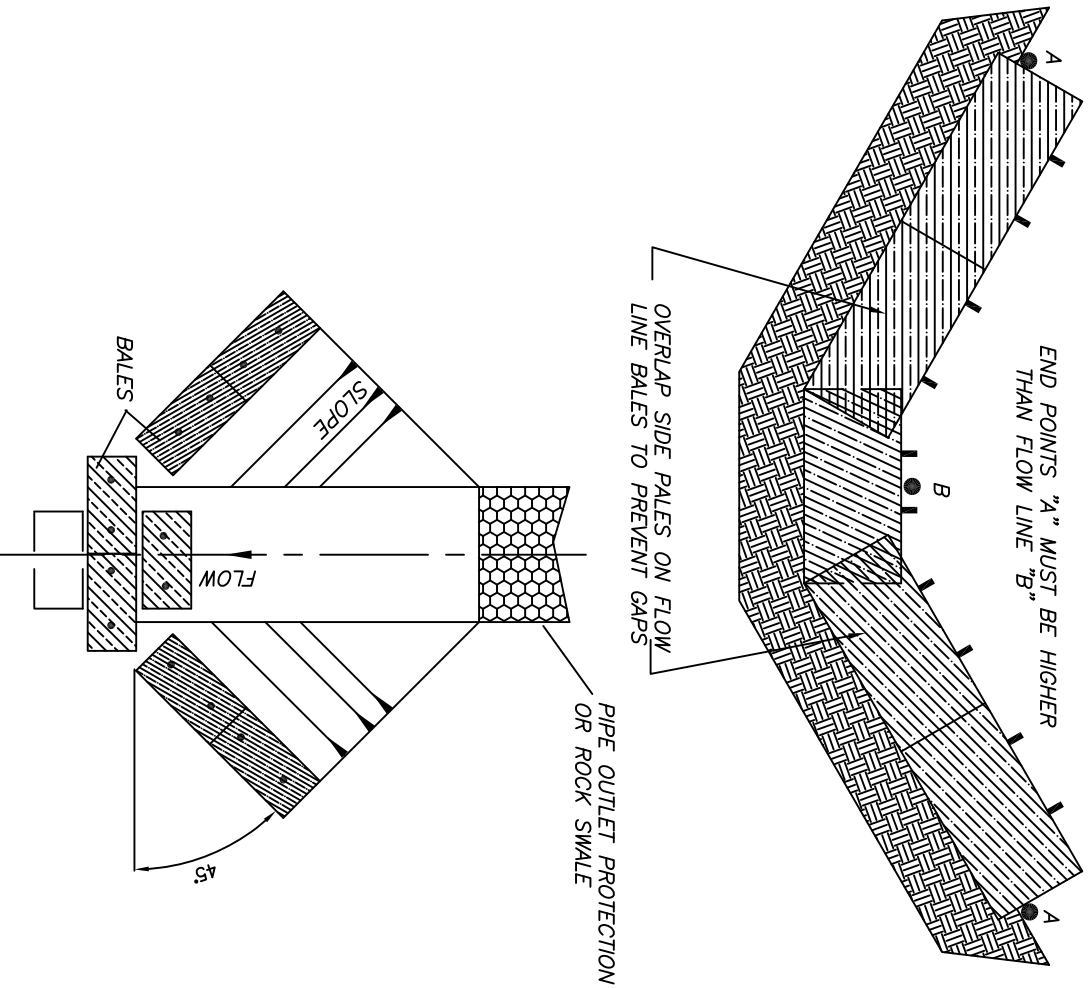

OUTLET STRAW BALE BARRIER

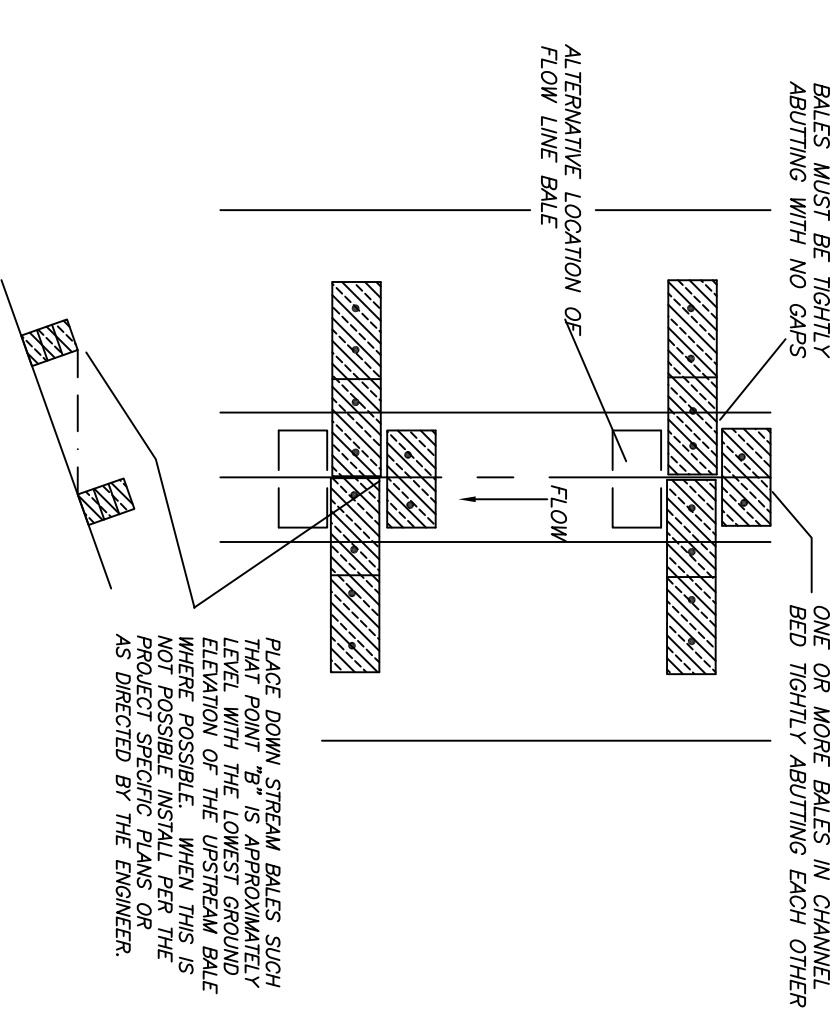

STRAW BALE CHECK STRUCTURE FOR WIDE DRAINAGE SWALES

CITY OF FRUITA  
ENGINEERING DEPARTMENT

SCALE  
HORIZONTAL: N/A  
VERTICAL: N/A

REVISION: 2009 STANDARDS REVISION  
REVISION:  
REVISION:

DATE: 3/18/09  
DATE:  
DATE:

STRAW BALES IN DRAINAGE SWALES

FILE:  
SHEET: 6.8F

DRAWN BY: CLD  
DATE DRAWN: 5/06  
CHECKED BY:

# CROSS-SECTION OF A PROPERLY INSTALLED STRAW BALE

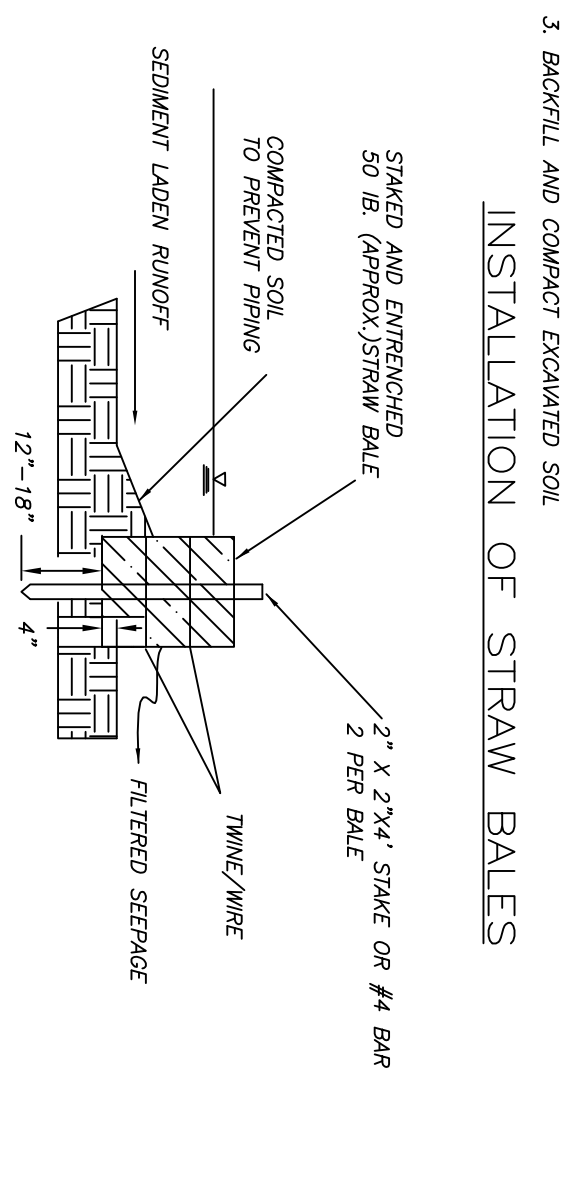
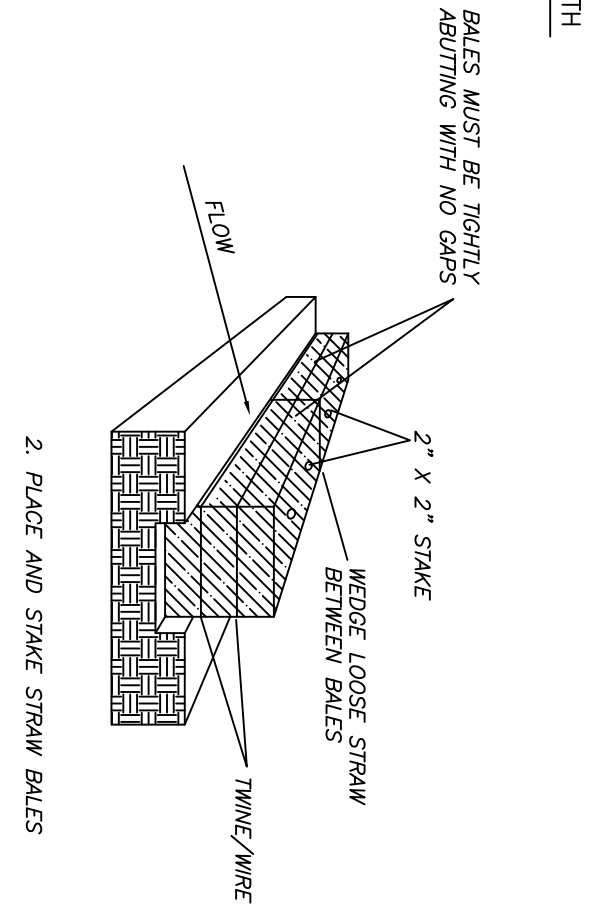
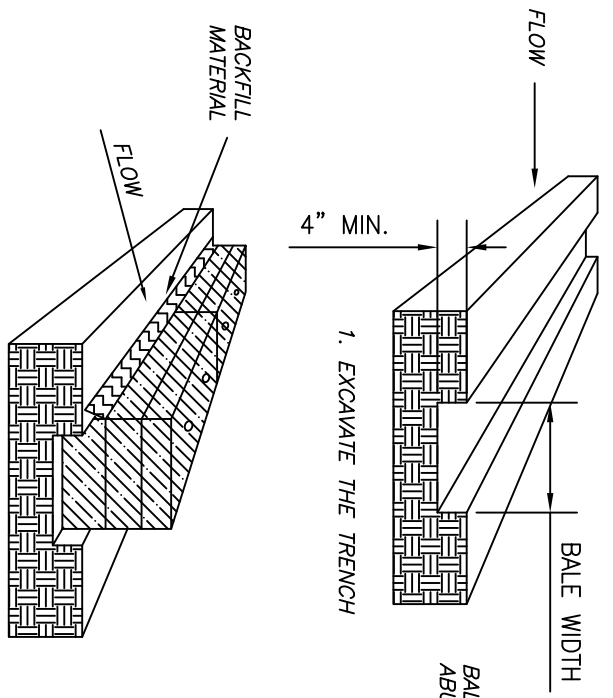

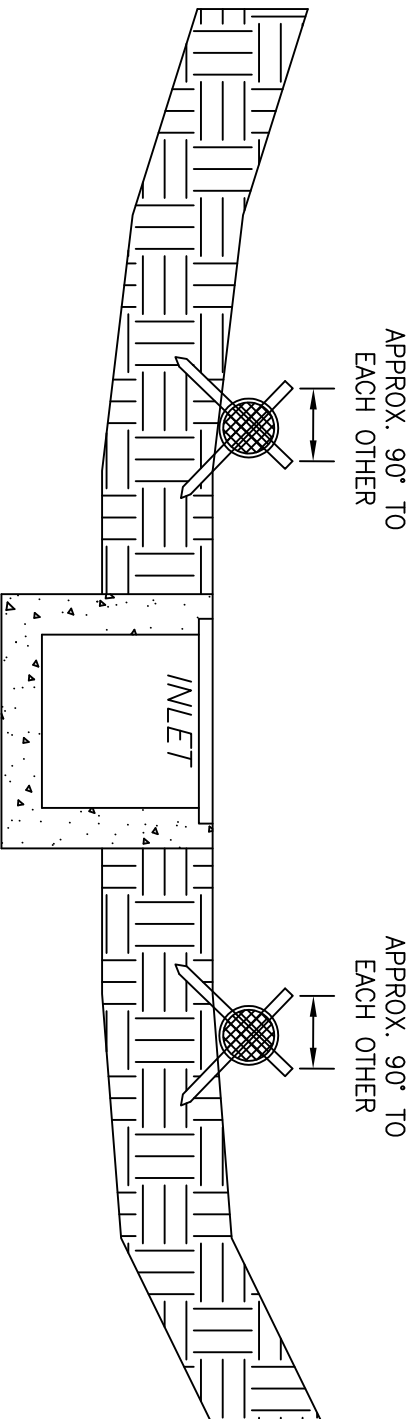
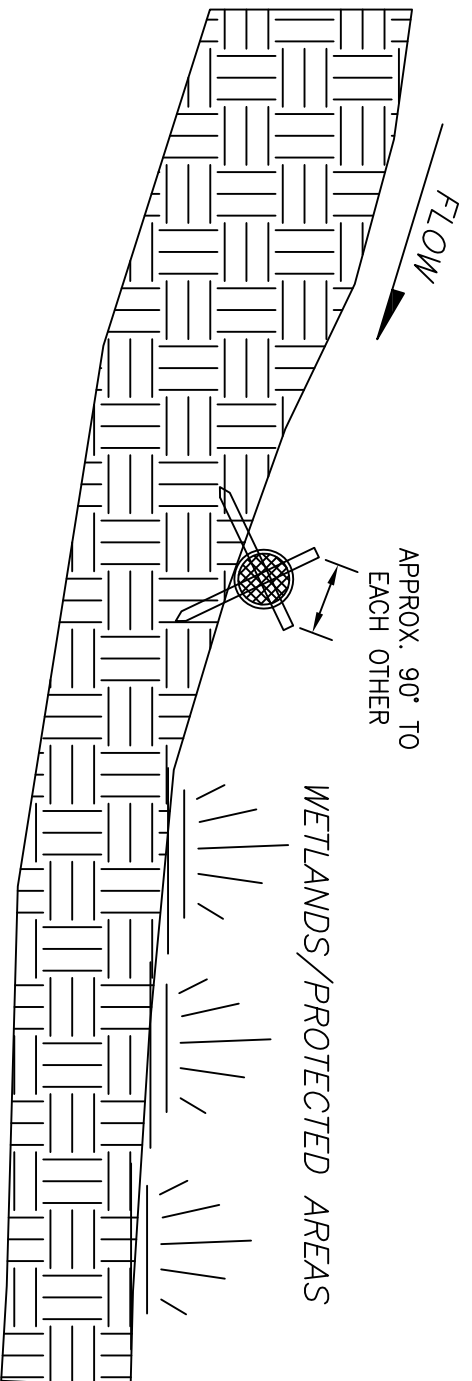

### Erosion Log Notes

1. Erosion logs should be installed upgradient of inlet perpendicular to and flush with the curb.
2. The maximum height of the curb log should be less than the top of the curb opening.
3. No less than two 10" diameter logs must be used in sequence, spaced no more than five feet apart, upgradient of inlet. No less than six logs shall be used if the 4" log is chosen. Incline at 30° from perpendicular, opposite direction of flow.
4. When using logs as check dams, place logs in reasonably straight ditch sections to minimize the potential for erosion in the channel.

## Mulching

Application of plant residues or other suitable material to the soil surface. Typical mulching material includes straw, hay, and wood cellulose fiber.

### I. Application

Used to provide temporary protection for exposed soils against erosion where temporary or permanent seeding operations are not feasible, especially during adverse growing seasons.

Used as part of seeding practices to protect newly seeded areas.

Used to protect soil stockpiles.

### II. Use Limitations

Use only on disturbed areas as a temporary cover.

Hydraulic mulching with wood cellulose fibers shall be limited to slopes steeper than 3:1 or where access is limited.

### III. Construction Guidelines

#### Material

Hay shall consist of native grasses free of noxious weed seeds.

Straw shall consist of clean cereal grain.

Wood cellulose fiber shall consist of virgin wood cellulose processed into a uniform fibrous physical state. Tackifiers (for anchoring) shall consist of a free flowing non-corrosive powder produced from the natural plant gum of Plantago Insularis (Desert Indianwheat). This material shall not contain any mineral filler, recycled cellulose fiber, clays, or other substances which may inhibit germination or growth of plants.

Spreading Procedure Hay and straw mulch shall be spread at a rate of two tons per acre.

At a minimum, 50% of the mulch, by weight, shall be 10 inches or more than two inches.

Applied mulch shall reach a uniform distribution so that no more than 10% of the soil surface shall be exposed.

Hay and straw mulch shall be anchored to the soil surface using Tackifiers, blankets, or nets, or with a mulch crimping machine., Mechanical anchoring is preferred and recommended for slopes flatter than 3:1. When using blankets or nets, these may need to be anchored to the soil with staples, or as required by the manufacturer's specifications.

Wood cellulose fiber mulch shall be mixed with water (maximum 50 lbs. of wood cellulose per 100 gallons of water) and a tackifying agent. Application shall be at a rate of 1500 pounds per acre with a hydraulic seeder or mulcher.

Tackifiers (for anchoring) shall be applied in a slurry with water and wood fiber (100 lbs. of powder and 150 lbs. of fiber per 700 gallons of water). Application rate of the powder shall be 100 lbs. per acre.

CITY OF FRUITA  
ENGINEERING DEPARTMENT

SCALE  
HORIZONTAL: N/A  
VERTICAL: N/A

REVISION: 2009 STANDARDS REVISION  
REVISION: \_\_\_\_\_  
REVISION: \_\_\_\_\_

DATE: 3/18/09  
DATE: \_\_\_\_\_  
DATE: \_\_\_\_\_

MULCHING NOTES

FILE:  
SHEET: 6.8I

DRAWN BY: CLD  
DATE DRAWN: 5/06  
CHECKED BY: \_\_\_\_\_

**Rock Properties**

Rock used for rip-rap or wire enclosed rip-rap should be hard, durable, angular in shape, and free from cracks, overburden, shale, and organic matter. Neither breadth nor thickness of a single stone should be less than 1/3 it's length and rounded stone should be avoided. The rock should sustain a loss of not more than 40 percent after 500 revolutions in a abrasion test (Los Angeles machine -ASTM C-535-69) and should sustain a loss of not more than 10 percent after 12 cycles of freezing and thawing (AASHTO test 103 for ledge rock procedure A). Rock having a minimum specific gravity of 2.65 is preferred; however, in no case shall rock have a specific gravity of less than 2.50.

**Placement**  
 Contractor to over-excavate subgrade under rip-rap a depth of 6 inches. Place MIRAFL 500X Geotextile fabric over excavated subgrade. Place 6 inches of topsoil material over fabric and rip-rap over topsoil.

**Gradation of Rip-Rap**

Percent Smaller Than Intermediate Rock Given Size by Weight Dimension (Inches)	d50 (Inches)
70-100	12
50-70	9
35-50	6
02-10	2
70-100	15
50-70	12
35-50	9
02-10	3
70-100	21
50-70	18
35-50	12
02-10	4
100	30
50-70	24
35-50	18
02-10	6
100	42
50-70	33
35-50	24
02-10	9

\*d50 = MEAN PARTICLE SIZE

\*\* BURY WITH NATIVE TOP SOIL AND REVEGETATE TO PROTECT FROM VANDALISM.

**Seeding**

Planting of temporary or permanent vegetation on all disturbed area.

I. Application

Disturbed areas not designated for immediate construction or permanent landscaping shall be temporarily revegetated. In the event construction activity ceases for a period of sixty (60) calendar days, disturbed areas including cut and fill slopes shall be revegetated with an annual and perennial seed mixture as indicated on the Erosion Control Plan.

II. Site Seed Mixture

- 15% Annual Rye Grass
- 25% Perennial Rye Grass
- 12% Nordan Crested Wheatgrass
- 12% Fairway Crested Wheatgrass
- 12% Blue Gramma
- 12% Red Fescue
- 12% Buffalo Grass

A minimum of 5 lbs/acre shall be used and planted using drill seeding methods and 10 lbs/acre when using a broadcast method.

III. Construction Guidelines

During permanent seeding, apply topsoil prior to applying seed. When use of fertilizers and herbicides is required, apply according to the manufacturer's recommended rates.

All seeding operations shall be performed at right angles to the slope.

When needed to improve germination of seeds, apply mulching immediately after seeding. Use soil retention blankets on steep slopes (2:1 and steeper). Some locations with 3:1 slopes facing south or west or 20 feet or more high may also require soil retention blankets.

Seeded areas shall be inspected frequently. Areas with failures shall be repaired and reseeded within the planting season.

CITY OF FRUITA ENGINEERING DEPARTMENT	SCALE HORIZONTAL: N/A VERTICAL: N/A	REVISION: 2009 STANDARDS REVISION REVISION: _____ REVISION: _____	DATE: 3/18/09 DATE: _____ DATE: _____	SEEDING NOTES & ROCK PROPERTIES	FILE: SHEET: 6.8J	DRAWN BY: CLD DATE DRAWN: 5/06 CHECKED BY: _____
--	---	---	---	---------------------------------	----------------------	--

A CRUSHED ROCK CONSTRUCTION STAGING PAD

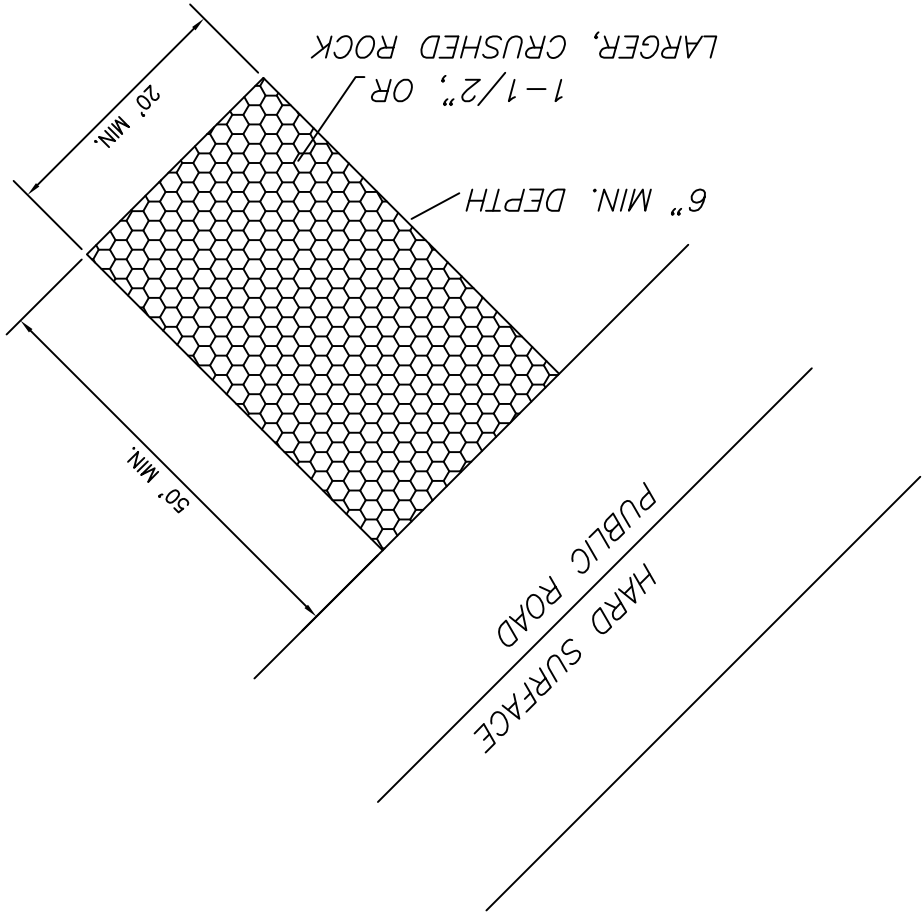

1. ENTRY INTO, AND EXIT FROM THE SITE BY ALL VEHICLES SHALL BE THROUGH A CONSTRUCTION STAGING AREA CONSISTING OF A CRUSHED ROCK PAD 50 FEET LONG (MIN.) AND 20 FEET WIDE (MIN.) WITH A THICKNESS OF AT LEAST 6" SEE DETAIL
2. CRUSHED ROCK SHALL BE 1 1/2 INCHES OR LARGER.
3. THE CRUSHED ROCK STAGING AREA SHALL BE IN PLACE WITHIN ONE WEEK AFTER OVERLOT GRADING COMMENCES.

A. SEDIMENT FROM CONSTRUCTION TRAFFIC

## Chapter 7

### IRRIGATION SYSTEM STANDARDS

#### Sections:

**7.1: General Provisions**

**7.2: Irrigation System Design Criteria**

**7.3 Irrigation Material Specifications for Pipe, Valves, and Fittings**

**7.4: Irrigation System Installation**

**7.5: Irrigation System Details**

**7.1: General Provisions**

- (A) A non-potable irrigation system is required for all subdivisions in areas accessible to existing irrigation ditch and canal systems
- (B) **Irrigation Design Report.** A system design report is required for all new improvement projects, including subdivisions, where irrigation is provided. The Design Report must include information related to owned and available irrigation water amounts, irrigation use, storage requirements, and a workable irrigation scheduling plan. Calculations of flow, time, etc. need to be included in the Report.
- (C) **Types of irrigation systems.** Three types of irrigation systems will be allowed as follows:
- (1) Concrete-lined open ditch system. This would typically be installed in Rural Agricultural or Rural Residential Zones consisting of minimum 3 and 2 acre lots. Open ditch systems are not allowed in residential areas.
  - (2) Low-head pipe systems. This would typically be installed where individual lot pumps would be utilized for pressure distribution.
  - (3) Pressurized pipe system. This would typically be installed where a centralized pump is utilized to provide a pressurized system for the entire subdivision.
- (D) **Number of irrigation shares.** The number of shares required for subdivision development as required by the City Land Use Code (1 1/2 -2 shares per acre).

- (E) **Irrigation Needs.** The irrigation demand shall be determined by using a consumptive use figure of three (3.0) inches per week. This is based on peak evapotranspiration of two (2) inches per week and an application efficiency of 70%. The weekly application of 3.0 inches must be applied to the total area of the development that will potentially receive irrigation.

**7.2: Irrigation System Design Criteria**

- (A) **Minimum Flow Rate.** The irrigation system shall provide the amount of water to fully supply each lot every other day, as a minimum. A minimum flow rate of 15 gpm is to be delivered to each lot. A flow rate of 30-35 gpm may be necessary for lots of one acre and larger in size. Where the development has areas designated as parks, greenbelt areas, etc. the irrigation system capacity must be adequate to service these areas in addition to the lots.

- (B) **Storage.** A water storage facility is required if the irrigation demand exceeds the available supply (number of shares). The storage facility must be fenced or otherwise enclosed for safety reasons. Storm water ponds shall not be utilized for irrigation storage facilities. Maintenance of storage facilities shall be the responsibility of the Developer/HOA.

- (C) **Line Pressure.** Pressurized pipe systems shall provide a pressure between 40 psi and 60 psi at each service.

(D) **Pipe Sizes and Type.**

(1) The minimum pipe size used in the main line of the system shall be 4 inches.

(2) Lines 4 inches in diameter and larger are to be constructed of pipe designed to withstand 160 psi.

(3) Lines 2 – 4 inches in diameter are to be constructed of Class 160 PVC or Class 200 PVC.

(4) Pump connection riser pipes are to be a minimum 2 inch in diameter constructed of pipe designed to withstand 160 psi.

(5) Pipelines 4 inches and smaller in diameter shall utilize two (2) 45 degree elbows at all changes of direction of 90 degrees, and shall be supported by one (1) cubic foot concrete thrust block.

(6) Cleanouts shall be provided in all pipelines at each 90 degree change in direction and at intervals no greater than 200 feet.



**(E) Valves.**

(1) Main line valves are to be standard cast brass globe valves with cast iron valve boxes. The tops of the boxes are to be adjusted such that they are no more than 2 inches above finish grade on grass or dry landscaping.

(2) Pipe systems shall have isolation valves in appropriate locations throughout the system to minimize interruption of service in the event that repairs are necessary and to aid in flushing the system.

(3) All riser pipes providing service to each residential lot shall be equipped with cast brass valves per standard drawing that can be opened and closed to accommodate testing the system, for acceptance by the City, and to facilitate the connection of individual lot pumps.

(4) If the system is designed for gravity draining, appropriate cast metal gate valves with valve boxes and a granular drain sump will be provided. An alternative is to drain the lines into an existing storm drain system. An alternative to gravity draining is to utilize compressed air, which will require attachment points for the compressed air lines.

(5) Low-head or pressurized systems will need air relief valves installed at any high points in the system to prevent air locks. Elevations necessary for control of slopes or grades to prevent high points should be noted on the drawings.

**(F) Miscellaneous.**

(1) All lots must be served directly off main lines. No services will be allowed to cross streets.

(2) All lots in the development shall be served by individual services.

(3) All pipe systems must provide a method for flushing the lines and for completely draining the lines.

(4) Irrigation lines placed under roadways while crossing from one block to another shall be encased in a larger PVC pipe.

(5) Angles in irrigation lines of 4 inches or larger are to be constructed and thrust blocked in the same manner as domestic water lines.

(6) All types of irrigation systems shall provide a means of removing trash and silt before it enters the system.

(7) Irrigation service lines will be located in irrigation easements normally along the rear lot lines. Some side lot lines can be utilized for this also, however this should be held to a minimum. Small in-fill developments within the older section of the residential township can have the irrigation service risers located along the front lot lines to utilize the existing feeder lines.

(8) Diversion directly from the regional irrigation lateral (pipe or ditch) where there are downstream users is not recommended. Diversion controls must be utilized, such as water flow meters, stand pipes or diversion boxes.

(9) **Flow measuring devices.** All systems requiring a water flow measuring device as described in (8) above shall install the device at or immediately below the point of diversion. If a water meter is used, it shall be of the type approved by the City.

**7.3: Irrigation Materials Specifications for Pipe, Valves, and Fittings.**

(A) **General.** All material shall be in new and undamaged condition. The specifications covering this item can be found in the Appendix.

**7.4: Irrigation System Installation.**

(A) **Gravity Flow Pipelines.** The installation specifications covering this item can be found in Section 3.4.

(1) **Testing of Lines.** Leakage testing of irrigation gravity flow pipelines is not required unless otherwise specified on the drawings.

(B) **Pressurized Pipelines.**

(1) **General.** Pipe shall be laid on the alignment shown on the plans. The inside of the pipe and jointing surfaces shall be kept clean and free from mud, dirt, gravel, ground water, and other foreign material. When pipe laying is not in progress the open ends of the pipeline shall be kept closed with watertight plugs.

Long radius horizontal or vertical curves may be laid with standard pipe by deflections at the joints of rigid pipe or by deflecting the entire length of flexible pipe. Maximum deflections at pipe joints shall be per the Manufacturer's recommendations of applicable AWWA Standard.

(2) **Thrust Restraint.** Thrust restraint shall be provided at all pipe bends, tees, caps, valves hydrants and at the end of all stub outs or dead end lines 4 inches and larger. Thrust restraint may be provided by concrete blocking or mechanical restraint. In-line valves with a minimum of 20 feet of pipe are not required to be separately restrained.

The size and location of concrete blocking shall be as shown on the plans or in accordance with the City Standard Drawings. Thrust blocks shall be poured on firm, stable foundation material and all bearing surfaces shall be against undisturbed earth. Concrete for thrust blocks shall be made with modified Type II Portland cement and shall reach a minimum compressive strength of 3000 psi in 28 days. Reinforcing steel and bolts used to anchor valves, fittings, etc., to thrust blocks shall meet tensile requirements of ASTM Grade 40. All anchorage steel not embedded in concrete shall be factory epoxy coated or Cor-Ten steel.

Valves and fittings may be restrained by mechanically connecting them to the pipe or other fittings. Fitting to fitting connections may be made with a flange by flange connection or an integral ring anchoring fitting by mechanical joint connection. Pipe by fitting connections shall be restrained with a Megalug, JCM, Uniflange Series 1500, Stargrip Series 4000 or other approved joint restraint. When using mechanical restraints, restraints shall also be used on the slip joints adjacent to the mechanical restraint. Where a short piece of pipe is installed between a fitting and a valve or other fitting, the restraint may be provided by connecting the mechanical joints with 5/8" zinc-coated, all-thread steel rod. The rod shall be connected to the mechanical joint fitting using tie-back bolts, not through the fitting's bolt holes. The rod shall be coated with an asphaltic sealant. All mechanical restraints shall be encased with polyethylene material, unless the soil is found to not be corrosive to ductile iron. The Project Engineer or the Contractor is required to submit a written request to the City to install the ductile iron without encasement. Polyethylene film shall have a minimum thickness of 0.008 inches (8mil). Installation of the polyethylene encasement shall be in accordance with one of the methods described in AWWA C-105.

**(3) Installation of Globe Valves and Valve Boxes.** Each globe valve shall be installed in a vertical position and set on a concrete support block as shown in the City Standard Drawings. An adjustable slip type valve box shall be set into position during backfilling operations. The upper section of the unit shall be placed in proper alignment and adjusted so that its top will be at final grade. The completed valve box shall be vertically centered over the valve operating nut. Each valve shall be checked for proper access and operation prior to placing any concrete or pavement around the box.

**(4) Installation of Butterfly Valves.** Unless otherwise approved by the City, each butterfly valve shall be installed in a vault. The diameter of the vault shall be as detailed on the plans.

**(5) Testing of Lines.** The contractor shall furnish the pump, pipe connections, taps, gauges, auxiliary water container, bulkheads, plugs and other necessary equipment and perform pressure and leakage tests on all

pressure lines unless otherwise directed by the City. All pressure pipelines shall be tested for pressure and leakage according to the following specifications. Pavement or other permanent surfaces shall not be placed until all pressure and leakage tests are satisfactorily completed. If the section of pipe being tested includes components of an existing system or components installed by others, the testing shall be done at the Contractor's risk.

Tests shall be conducted on all pipelines or valve sections thereof. Tests on lines anchored or blocked by concrete shall not be conducted until the concrete has taken permanent set.

Hydrostatic leakage testing shall be performed in conformance to the applicable sections of AWWA C-600 except as modified below. Unless otherwise authorized by the City, all hydrostatic leakage tests shall be witnessed by the City.

The pipeline shall be filled with water at least twenty-four (24) hours before being subjected to the hydrostatic pressure test. Each section of pipe shall be filled slowly and all air expelled by means of taps at points of highest elevation. If permanent air vents are not located at all high points, the Contractor shall install corporation cocks at such points so that the air can be expelled as the line is filled with water. After all the air has been expelled, the corporation cocks shall be removed and plugged or left in place at the discretion of the City.

The pressure test shall be 150 lbs. /sq. in., or 50 percent (50%) above the normal operating pressure, whichever is greater. Hydrostatic pressure shall be applied by pumping water from an auxiliary supply. The Contractor shall accurately determine the amount of water required to reach the initial test pressure and the amount required to repressurize the pipe structure at the completion of the test period.

The test pressure shall be maintained for a minimum of four (4) hours and additional time as required for thorough inspection to find any leaks or defects in the water main and appurtenances. Should the pipe section fail to pass the tests, the Contractor shall find and correct failures and repeat the tests until satisfactory results are obtained.

The pressure and leakage tests may be performed simultaneously or separately. The total time for the combined pressure and leakage tests shall be a minimum of two (2) hours for each section of pipeline.

**(6) Allowable Leakage.** No pipe installation will be accepted if the leakage is greater than that determined by the formula outlined below.

$$\frac{=SD\sqrt{P}}{133,200}$$

**Where:** L = allowable leakage, in gallons per hour  
 S = length of pipe tested, in feet  
 D = nominal diameter of pipe, in inches  
 P = average test pressure during the leakage test, in Pounds per square inch (gauge)

**NOTE:** This formula is based on an allowable leakage of 11.65 gpd/mi./in. of nominal diameter at a pressure of 150 psi.

The allowable leakage in gallons per hour at various pressures and pipe sizes is shown below. In the event of discrepancies between formulas and table values, the more stringent will apply.

**TABLE ONE**

**ALLOWABLE LEAKAGE PER 1,000 FEET OF PIPELINE - gph**

AVG. TEST PRESSURE psi	NOMINAL PIPE DIAMETER - in									
	3	4	6	8	10	12	14	16	18	20
250	0.36	0.47	0.71	0.95	1.19	1.42	1.66	1.90	2.14	2.37
225	0.34	0.45	0.68	0.90	1.13	1.35	1.58	1.80	2.03	2.25
200	0.32	0.43	0.64	0.85	1.06	1.28	1.48	1.70	1.91	2.12
175	0.30	0.40	0.59	0.80	0.99	1.19	1.39	1.59	1.79	1.98
150	0.28	0.37	0.55	0.74	0.92	1.10	1.29	1.47	1.66	1.84
125	0.25	0.34	0.50	0.67	0.84	1.01	1.18	1.34	1.51	1.68
100	0.23	0.30	0.45	0.60	0.75	0.90	1.05	1.20	1.35	1.50

- (7) **Minimum Depth.** All irrigation lines are to have a minimum of two (2) feet bury (top of pipe to finish grade).
- (8) **Backfill.** The backfilling of irrigation trenches shall be in accordance with the standard trench detail.
- (9) **Tracer Wire.** All irrigation main lines shall have a tracer wire. Electrical tracing wire shall be size No. 10, Type UF solid copper, direct bury wire. Splices shall be compression type designed for direct bury application.
- (10) As-built drawings must be submitted to the Public Works Department.

**7.5 Irrigation System Details**

**A. Irrigation Construction Notes**

**B. Irrigation Riser on City System Detail**

IRRIGATION CONSTRUCTION NOTES:

1. 4" AND LARGER IRRIGATION LINES ARE TO BE CONSTRUCTED OF BELL AND SPIGOT CLASS 200 PVC.
2. 2" IRRIGATION MAIN LINES ARE TO BE CONSTRUCTED OF CLASS 200 PVC. 2" IRRIGATION SERVICE LINES ARE TO BE CONSTRUCTED OF CLASS 160 PVC.
3. PUMP CONNECTION RISERS WILL BE CONSTRUCTED OF SCHEDULE 40 PVC.
4. GRADES AND ELEVATIONS ARE NOTED ONLY WHERE THE NATURAL GROUND SLOPE IS INSUFFICIENT TO INSURE FREE DRAINING. TAKE CARE TO INSURE THAT NO HIGH OR LOW POINTS ARE CREATED SUCH THAT THE LINES WILL NOT FREELY DRAIN.
5. ANGLES IN IRRIGATION LINES ARE TO BE CONSTRUCTED AND THRUST BLOCKED IN THE SAME MANNER AS POTABLE WATERLINES.
6. BACKFILLING OF IRRIGATION TRENCHES SHALL BE IN ACCORDANCE WITH THE STANDARD TRENCH DETAIL (SEE DETAIL ON THIS SHEET).
7. ALL VALVES ARE TO BE STANDARD BRASS POTABLE WATER GLOBE VALVE WITH CAST IRON VALVE BOXES.
8. ALL IRRIGATION LINES ARE TO HAVE A MINIMUM OF 2' BURY (TO TOP OF PIPE).

CITY OF FRUITA  
ENGINEERING DEPARTMENT

SCALE  
HORIZONTAL: N/A  
VERTICAL: N/A

REVISION: 2009 STANDARDS REVISION      DATE: 3/18/09  
REVISION: \_\_\_\_\_      DATE: \_\_\_\_\_  
REVISION: \_\_\_\_\_      DATE: \_\_\_\_\_

IRRIGATION CONSTRUCTION  
NOTES

FILE:  
SHEET: 7.5A

DRAWN BY: CLD  
DATE DRAWN: 5/06  
CHECKED BY: \_\_\_\_\_

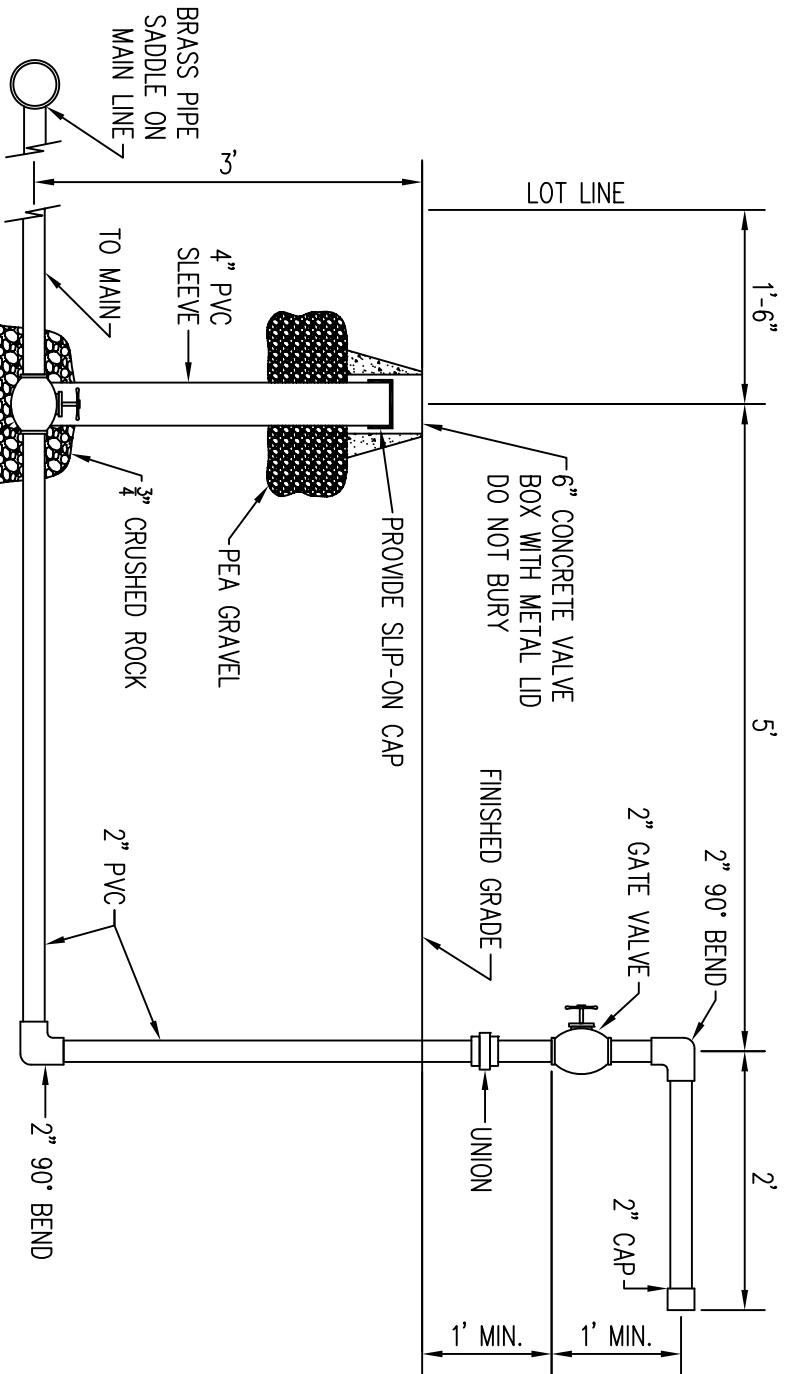

TYPICAL IRRIGATION RISER DETAIL  
 (FOR NEW CONNECTIONS TO CITY SYSTEM)

NOTE: VALVE AND RISER MUST BE ACCESSIBLE TO THE CITY OF FRUITA. WHERE LOT IS FENCED, VALVE AND RISER MUST BE LOCATED OUTSIDE THE FENCE.



## Chapter 8

### DEVELOPMENT INSPECTION AND QUALITY ACCEPTANCE

#### Sections:

#### 8.1 Required Quality Control and Assurance

#### 8.2 Materials Testing Reports

#### 8.3 Field Testing Procedures

#### 8.1 Required Quality Control and Assurance – QA/QC

(A) Adequate quantity and quality of observation and testing during the construction process is essential to achieving a quality product. Consequently, the City of Fruita requires Quality Control and Quality Assurance testing during the construction of:

- (1) Facilities that will become public, such as streets, sidewalks, water, sewer and storm drains, and
- (2) Facilities that ultimately impact the public at large, such as Stormwater Best Management Practices (BMPs) overlot grading, private detention/retention basins and storm water collection and conveyance.

(B) Responsibility: The Applicant is legally responsible for quality control and assurance of the development project. The Applicant, engineer and/or the contractor- as the Applicant's agent(s) – shall implement the procedures, methods, testing, surveying and observation that are required by the City to insure the work conforms to all City specifications.

- (1) Laboratory and Field Testing Requirements.

Laboratory and Field Testing Requirements. All sampling and testing shall be performed by qualified technicians using the proper equipment as required by each test procedure.

Hot Mix Asphalt. Personnel performing sampling and testing of aggregates for hot mix asphalt (HMA) or bituminous mixtures shall possess the appropriate CAPA (LabCat) certification or combination of certifications for all sampling and testing performed. CAPA certifications include: A – Laydown, B – Asphalt Plant Materials Control, C – Mixture Volumetrics and Stability and E – Aggregates.

Soil and Aggregates. Technicians performing testing of soils or aggregates for road base or embankment construction shall be NICET Level II, or WAQTC certified.

Portland Cement Concrete. Personnel conducting field testing of concrete must be American Concrete Institute (ACI) certified as a Concrete Field Testing Technician Grade I. Field testing of concrete includes slump, temperature, air content, wet unit weight and the making of compressive strength cylinders.

Effective on May 1, 2009, personnel conducting compressive strength tests must be either ACI certified as a Concrete Laboratory Testing Technician Grade I or as a Concrete Strength Testing Technician.

Effective on May 1, 2009, hand finishing concrete will be permitted only when performed under the direct supervision of a Craftsman holding the following certificate: ACI Concrete Flatwork Finisher and Technician (ACICFFT) or other Flatwork Finisher certification program approved by the City.

Time Limits for Acceptance Testing by Non-qualified New Employees. A maximum of two calendar months of continuous testing before certification is required. Accumulation of time is not allowed.

(C) City Inspection: In addition to Quality Control (QC) and Quality Assurance (QA) provided by the Applicant and his Agent(s), the City will perform spot inspections of the construction of any facilities at their discretion. A City Inspector or City Engineer will make periodic inspections of the work. Such inspections of the work by the City do not relieve the Applicant of their obligation(s) to observe, monitor and conduct necessary tests.

The City Inspector and/or the City Engineer may require work to be uncovered or removed if QC/QA to the City of Fruita Standards are not provided to the satisfaction of the City Inspector and/or the City Engineer.

(D) Construction Segmentation: As construction proceeds, the quality or acceptability of work often depends upon the preceding quality of work. Any or all work on a development may be stopped until QC/QA observations and tests are taken/provided and/or City approval(s) of the same are given.

**8.2 Materials Testing Reports.** All materials properties and material compaction test reports according to the method and frequency required by the City Standard Construction Documents or tests and observations required by special geotechnical recommendations shall be submitted to the Engineering Department as follows:

(A) Compaction Test Results. Compaction test results indicating location, proctor (including full gradation and PI), minimum requirements, test methods and results shall be reported for all tests. Retests shall be indicated. Failing results for moisture or density shall be flagged.

A unique and recognizable location including depth, strata (subgrade, finish grade, etc.), type of utility trench or position in the road structure (subgrade, sidewalk) shall be identified for each test. Abbreviations or codes shall be included in the legend. Original typed compaction test reports approved by the certified laboratory supervisor or engineer are required for project acceptance.

(B) Cementitious and Asphaltic Test Reports. Complete materials tests reports for Portland cement concrete and asphalt concrete materials, including all materials properties, are required by the materials testing requirements listed in the City of Fruita *Design Criteria and Construction Specification Manual* shall be submitted. Failing results on any material test property shall be flagged.

A unique and recognizable location shall be identified for each test. Abbreviation or codes shall be included in the legend. Original materials reports approved by the certified laboratory supervisor or engineer are required for project acceptance.

(C) Testing Location Maps. Size 11" x 17" or 24" x 36" using composite plan as a base map, prepared by the testing agency shall be submitted indicating the location of all compaction and materials test locations. A methodology for identifying different areas of compaction tests (sewer, water, utility, subgrade, base course, etc.) shall be used. Depth of materials tests shall be indicated.

(D) Material Properties. All materials proctors, full gradations, plasticity indexes, etc. shall be submitted to the City.

- (E) Test Failures. All test results including failing materials test results must be submitted to the City within 15 days.
  
- (F) Acceptance of Test Results. Before concrete and asphalt are placed, plotted test results of all previous tests in the Right-of-Way must be accepted by the City. When failing tests, missing tests or ambiguous tests are not corrected, requests for retests and removal of overlying structures/materials shall be performed.
  - (1) Plotted density tests for sanitary sewer, water, storm sewer, utility crossings and subgrade for streets and sidewalks shall be provided to the City for approval prior to any base being placed.
  
  - (2) Structural fill densities for sidewalks, pans, fillets and ramps shall be submitted to the City and approved prior to concrete placement.
  
  - (3) Plotted test results for streets and sidewalks must be submitted and approved by the City prior to placing asphalt.

**8.3 Field Testing Procedures:** It is important to observe the following field testing procedures and obligations while testing in the City of Fruita Right-of-Way:

- (A) Nuclear gauge testing of moisture/density – all soils and base courses shall be tested using the direct transmission method. At least 6” probe depth shall be used for all soils in trenches, subgrades, embankments, etc. Backscatter method for nuclear moisture/density testing is specifically not allowed unless approved in writing by the City.
  
- (B) Class 6 aggregate base courses and other base courses should be tested two inches less than the total lift depth. (For example, a 6” thick base course should be tested 4” probe depth.) It is not necessary to test more than 6” probe depth on base courses that are 8” or thicker, unless job site specifications prevail.
  
- (C) Asphalt density by nuclear gauge shall be tested by backscatter unless specific job requirements require direct transmission.
  
- (D) Updated copies of compressive strength tests of concrete shall be sent to the City regularly.

(E) The City reserves the right to procure raw test data in the field at the time of testing.